

A USER GUIDE FOR DRAGON VERSION5

G. MARLEAU, A. HÉBERT AND R. ROY



## Copyright Notice for DRAGON

The development of DRAGON is financially supported, directly or indirectly, by various organizations including École Polytechnique de Montréal, Hydro-Québec and the Hydro-Québec chair in nuclear engineering, the Natural Science and Engineering Research Council of Canada (NSERC), Atomic Energy of Canada limited (AECL) and the CANDU Owners Group (COG). The code DRAGON and its users guide are and will remain the property of École Polytechnique de Montréal. The PostScript utility module used in DRAGON is based on PSLOT which is owned by Kevin E. Kohler at the Nova Southeastern University Oceanographic Center in Florida.

Dragon is free software; you can redistribute it and/or modify it under the terms of the GNU Lesser General Public License as published by the Free Software Foundation; either version 2.1 of the License, or (at your option) any later version.

Permission is granted to the public to copy DRAGON without charge. École Polytechnique de Montréal, makes no warranty, express or implied, and assumes no liability or responsibility for the use of DRAGON.

## Acknowledgments

The computer code DRAGON results from a concerted effort made at École Polytechnique de Montréal. The main authors of this report would therefore like to express their thanks to École Polytechnique de Montréal for its support along the years as well as to the graduate students and research associates which have contributed to the development of DRAGON along the years. We would also like to thank Kevin E. Kohler at the Nova Southeastern University Oceanographic Center for letting us use and distribute a PostScript utility module derived from his PSLOT package. Finally, the DRAGON team would never have survived without the financial support of the Natural Science and Engineering Research Council of Canada (NSERC), Hydro-Québec, Atomic Energy of Canada limited (AECL) and the CANDU Owners Group (COG).

## SUMMARY

The computer code DRAGON contains a collection of models which can simulate the neutronic behaviour of a unit cell or a fuel assembly in a nuclear reactor. It includes all of the functions that characterize a lattice cell code, namely: the interpolation of microscopic cross sections which are supplied by means of standard libraries; resonance self-shielding calculations in multidimensional geometries; multigroup and multidimensional neutron flux calculations which can take into account neutron leakage; transport-transport or transport-diffusion equivalence calculations as well as editing of condensed and homogenized nuclear properties for reactor calculations; and finally isotopic depletion calculations.

The code DRAGON contains a multigroup iterator conceived to control a number of different algorithms for the solution of the neutron transport equation. Each of these algorithms is presented in the form of a one-group solution procedure where the contributions from other energy groups are included in a source term. The current version of DRAGON contains many such algorithms. The SYBIL option which solves the integral transport equation using the collision probability method for simple one-dimensional (1-D) geometries (either plane, cylindrical or spherical) and the interface current method for 2-D Cartesian or hexagonal assemblies. The EXCELL, NXT and SALT options which solve the integral transport equation using the collision probability method for general 2-D geometries and for three-dimensional (3-D) assemblies. The MCCG option solves the integro-differential transport equation using the long characteristics method for general 2-D and 3-D geometries.

The execution of DRAGON is controlled by the CLE-2000 supervisor. It is modular and can be interfaced easily with other production codes.

## Contents

|  |          |
|--|----------|
| Copyright Notice for DRAGON . . . . .  | ii       |
| Acknowledgments . . . . .  | iii      |
| Contents . . . . .   | v        |
| List of Figures . . . . .  | ix       |
| List of Tables . . . . .   | x        |
| <b>1 INTRODUCTION . . . . .</b>  | <b>1</b> |
| <b>2 GENERAL STRUCTURE OF THE DRAGON INPUT . . . . .</b>                       | <b>2</b> |
| 2.1 Data organization . . . . .  | 2        |
| 2.2 DRAGON Data Structure and Module Declarations . . . . .                    | 3        |
| 2.3 The DRAGON Modules . . . . .   | 4        |
| 2.4 The Utility Modules . . . . .  | 6        |
| 2.5 The DRAGON Data Structures . . . . .                                       | 6        |
| 2.6 Main Updates in DRAGON . . . . .   | 7        |
| <b>3 THE DRAGON MODULES . . . . .</b>  | <b>9</b> |
| 3.1 The MAC: module . . . . .  | 9        |
| 3.1.1 Input structure for module MAC: . . . . .                                | 10       |
| 3.1.2 Macroscopic cross section definition . . . . .                           | 12       |
| 3.1.3 Update structure for operator MAC: . . . . .                             | 15       |
| 3.2 The LIB: module . . . . .  | 16       |
| 3.2.1 Data input for module LIB: . . . . .                                     | 16       |
| 3.2.2 Depletion data structure . . . . .                                       | 23       |
| 3.2.3 Mixture description structure . . . . .                                  | 24       |
| 3.2.4 Cross sections in Dragon . . . . .                                       | 29       |
| 3.3 The GEO: module . . . . .  | 31       |
| 3.3.1 Data input for module GEO: . . . . .                                     | 31       |
| 3.3.2 Boundary conditions . . . . .  | 34       |
| 3.3.3 Spatial properties of geometry . . . . .                                 | 43       |
| 3.3.4 Physical properties of geometry . . . . .                                | 48       |
| 3.3.5 Double-heterogeneity . . . . .   | 61       |
| 3.3.6 Do-it-yourself geometries . . . . .                                      | 61       |
| 3.4 The tracking modules . . . . .   | 63       |
| 3.4.1 The SYBILT: tracking module . . . . .                                    | 65       |
| 3.4.2 The EXCELT: tracking module . . . . .                                    | 68       |
| 3.4.3 The NXT: tracking module . . . . .                                       | 72       |
| 3.4.4 The MCCGT: tracking module . . . . .                                     | 77       |
| 3.4.5 The SNT: tracking module . . . . .                                       | 80       |
| 3.4.6 The BIVACT: tracking module . . . . .                                    | 84       |
| 3.4.7 The TRIVAT: tracking module . . . . .                                    | 87       |
| 3.5 The ASM: module . . . . .  | 89       |
| 3.5.1 Data input for module ASM: . . . . .                                     | 89       |
| 3.6 The FLU: module . . . . .  | 92       |
| 3.6.1 Data input for module FLU: . . . . .                                     | 93       |
| 3.6.2 Leakage model specification structure . . . . .                          | 95       |
| 3.7 The EDI: module . . . . .  | 99       |
| 3.7.1 Data input for module EDI: . . . . .                                     | 100      |
| 3.7.2 Homogenization and condensation with the flux . . . . .                  | 107      |
| 3.7.3 Homogenization and condensation with the flux and adjoint flux . . . . . | 107      |
| 3.8 The EVO: module . . . . .  | 109      |
| 3.8.1 Data input for module EVO: . . . . .                                     | 111      |
| 3.8.2 Power normalization in EVO: . . . . .                                    | 115      |
| 3.9 The SPH: module . . . . .  | 116      |
| 3.9.1 Data input for module SPH: . . . . .                                     | 117      |
| 3.9.2 Specification for the type of equivalence calculation . . . . .          | 118      |

|        |   |     |
|--------|---|-----|
| 3.10   | The CFC: module . . . . .   | 123 |
| 3.10.1 | Data input for module CFC: . . . . .  | 124 |
| 3.11   | The INFO: module . . . . .  | 126 |
| 3.11.1 | Data input for module INFO: . . . . .   | 126 |
| 3.12   | The MRG: module . . . . .   | 129 |
| 3.12.1 | Data input for geometry pre-homogenization . . . . .                              | 129 |
| 3.12.2 | Data input for tracking file partitioning . . . . .                               | 130 |
| 3.13   | The COMPO: module . . . . .   | 131 |
| 3.13.1 | Initialization data input for module COMPO: . . . . .                             | 133 |
| 3.13.2 | Modification data input for module COMPO: . . . . .                               | 136 |
| 3.13.3 | Modification (catenate) data input for module COMPO: . . . . .                    | 137 |
| 3.13.4 | Display data input for module COMPO: . . . . .                                    | 138 |
| 3.14   | The TLM: module . . . . .   | 139 |
| 3.14.1 | Data input for module TLM: . . . . .  | 139 |
| 3.15   | The M2T: module . . . . .   | 142 |
| 3.15.1 | Data input for module M2T: . . . . .  | 142 |
| 3.16   | The CHAB: module . . . . .  | 144 |
| 3.16.1 | Data input for module CHAB: . . . . .   | 144 |
| 3.17   | The CPO: module . . . . .   | 146 |
| 3.17.1 | Data input for module CPO: . . . . .  | 146 |
| 3.18   | The SAP: module . . . . .   | 148 |
| 3.18.1 | Initialization data input for module SAP: . . . . .                               | 150 |
| 3.18.2 | Modification data input for module SAP: . . . . .                                 | 152 |
| 3.18.3 | Modification (catenate) data input for module SAP: . . . . .                      | 153 |
| 3.19   | The MPO: module . . . . .   | 155 |
| 3.19.1 | Initialization data input for module MPO: . . . . .                               | 157 |
| 3.19.2 | Modification data input for module MPO: . . . . .                                 | 159 |
| 3.19.3 | Modification (catenate) data input for module MPO: . . . . .                      | 160 |
| 3.19.4 | Specification of discontinuity factor and equivalent albedo information . . . . . | 161 |
| 3.20   | The MC: module . . . . .  | 162 |
| 3.20.1 | Data input for module MC: . . . . .   | 162 |
| 3.21   | The T: module . . . . .   | 164 |
| 3.22   | The DMAC: module . . . . .  | 165 |
| 3.22.1 | Data input for module DMAC: . . . . .   | 165 |
| 3.23   | The SENS: module . . . . .  | 167 |
| 3.23.1 | Data input for module SENS: . . . . .   | 167 |
| 3.24   | The DUO: module . . . . .   | 169 |
| 3.24.1 | Data input for module DUO: . . . . .  | 169 |
| 3.24.2 | Theory . . . . .  | 170 |
| 3.25   | The S2M: module . . . . .   | 172 |
| 3.25.1 | Data input for module S2M: . . . . .  | 172 |
| 3.26   | The FMT: module . . . . .   | 173 |
| 3.27   | The FMAC: module . . . . .  | 175 |
| 3.27.1 | Data input for module FMAC: . . . . .   | 175 |
| 3.28   | The PSOUR: module . . . . .   | 176 |
| 3.28.1 | Data input for module PSOUR: . . . . .  | 176 |
| 3.29   | The HEAT: module . . . . .  | 179 |
| 3.29.1 | Data input for module HEAT: . . . . .   | 179 |
| 3.30   | The BREF: module . . . . .  | 181 |
| 3.30.1 | Data input for module BREF: . . . . .   | 183 |
| 3.31   | The PSP: module . . . . .   | 185 |
| 3.31.1 | Data input for module PSP: . . . . .  | 185 |
| 3.32   | The CLM: module . . . . .   | 187 |
| 3.32.1 | Data input for module CLM: . . . . .  | 187 |
| 4      | THE RESONANCE SELF-SHIELDING MODULES . . . . .                                    | 189 |

|        |   |     |
|--------|---|-----|
| 4.1    | The SHI: module . . . . .   | 189 |
| 4.1.1  | Data input for module SHI: . . . . .  | 189 |
| 4.2    | The TONE: module . . . . .  | 192 |
| 4.2.1  | Data input for module TONE: . . . . .   | 192 |
| 4.3    | The USS: module . . . . .   | 194 |
| 4.3.1  | Data input for module USS: . . . . .  | 195 |
| 4.4    | The AUTO: module . . . . .  | 198 |
| 4.4.1  | Data input for module AUTO: . . . . .   | 199 |
| 4.5    | The VDG: module . . . . .   | 202 |
| 4.5.1  | Data input for module VDG: . . . . .  | 202 |
| 5      | THE SALOME-RELATED MODULES . . . . .  | 204 |
| 5.1    | The G2S: module . . . . .   | 204 |
| 5.1.1  | Data input for module G2S: . . . . .  | 205 |
| 5.2    | The G2MC: module . . . . .  | 207 |
| 5.2.1  | Data input for module G2MC: . . . . .   | 207 |
| 5.3    | The SALT: tracking module . . . . .   | 209 |
| 5.3.1  | Cyclic tracking . . . . .   | 209 |
| 5.3.2  | Calling specifications . . . . .  | 209 |
| 6      | THE UTILITY MODULES . . . . .   | 214 |
| 6.1    | The equality module . . . . .   | 214 |
| 6.2    | The UTL: module . . . . .   | 215 |
| 6.3    | The HUTL: module . . . . .  | 217 |
| 6.4    | The DELETE: module . . . . .  | 219 |
| 6.5    | The BACKUP: module . . . . .  | 220 |
| 6.6    | The RECOVER: module . . . . .   | 221 |
| 6.7    | The ADD: module . . . . .   | 222 |
| 6.8    | The MPX: module . . . . .   | 223 |
| 6.9    | The STAT: module . . . . .  | 224 |
| 6.10   | The GREP: module . . . . .  | 225 |
| 6.11   | The MSTR module . . . . .   | 227 |
| 6.12   | The FIND0: module . . . . .   | 229 |
| 6.13   | The ABORT: module . . . . .   | 230 |
| 6.14   | The END: module . . . . .   | 231 |
| 7      | THE MPI MODULES . . . . .   | 232 |
| 7.1    | The DRVMPI: module . . . . .  | 232 |
| 7.2    | The SNDMPI: module . . . . .  | 233 |
| 8      | EXAMPLES . . . . .  | 234 |
| 8.1    | Scattering cross sections . . . . .   | 234 |
| 8.2    | Geometries . . . . .  | 234 |
| 8.3    | MATXS7A microscopic cross-section examples . . . . .                            | 240 |
| 8.3.1  | (TCXA01) – The Mosteller benchmark. . . . .                                     | 240 |
| 8.4    | Macroscopic cross sections examples . . . . .                                   | 244 |
| 8.4.1  | (TCM01) – Annular region . . . . .  | 244 |
| 8.4.2  | (TCM02) – The Stankovski test case. . . . .                                     | 245 |
| 8.4.3  | (TCM03) – Watanabe and Maynard problem with a void region. . . . .              | 247 |
| 8.4.4  | (TCM04) – Adjuster rod in a CANDU type supercell. . . . .                       | 252 |
| 8.4.5  | (TCM05) – Comparison of leakage models . . . . .                                | 255 |
| 8.4.6  | (TCM06) – Buckling search without fission source . . . . .                      | 259 |
| 8.4.7  | (TCM07) – Test of boundary conditions . . . . .                                 | 261 |
| 8.4.8  | (TCM08) – Fixed source problem with fission . . . . .                           | 262 |
| 8.4.9  | (TCM09) – Solution of a 2-D fission source problem using MCGT: . . . . .        | 264 |
| 8.4.10 | (TCM10) – Solution of a 2-D fixed source problem using MCGT: . . . . .          | 267 |
| 8.4.11 | (TCM11) – Comparison of CP and MoC solutions . . . . .                          | 269 |
| 8.4.12 | (TCM12) – Solution of a 3-D problem using the MCU: module . . . . .             | 273 |
| 8.4.13 | (TCM13) – Hexagonal assembly with hexagonal cells containing clusters . . . . . | 274 |

|        |  |     |
|--------|--|-----|
| 8.5    | WIMSD4 microscopic cross-section examples. . . . .                           | 277 |
| 8.5.1  | (TCWU01) – The Mosteller benchmark. . . . .                                  | 277 |
| 8.5.2  | (TCWU02) – A $17 \times 17$ PWR type assembly . . . . .                      | 279 |
| 8.5.3  | (TCWU03) – An hexagonal assembly . . . . .                                   | 283 |
| 8.5.4  | (TCWU04) – A Cylindrical cell with burnup. . . . .                           | 286 |
| 8.5.5  | (TCWU05) – A CANDU-6 type annular cell with burnup. . . . .                  | 290 |
| 8.5.6  | (TCWU06) – A CANDU-6 type supercell with control rods. . . . .               | 294 |
| 8.5.7  | (TCWU07) – A CANDU-6 type calculation using various leakage options. . . . . | 297 |
| 8.5.8  | (TCWU08) – Burnup of an homogeneous cell. . . . .                            | 300 |
| 8.5.9  | (TCWU09) – Testing boundary conditions. . . . .                              | 302 |
| 8.5.10 | (TCWU10) – Fixed source problem in multiplicative media. . . . .             | 304 |
| 8.5.11 | (TCWU11) – Two group burnup of a CANDU-6 type cell. . . . .                  | 305 |
| 8.5.12 | (TCWU12) – Mixture composition. . . . .                                      | 308 |
| 8.5.13 | (TCWU13) – Solution by the method of cyclic characteristics . . . . .        | 311 |
| 8.5.14 | (TCWU14) – SPH Homogenisation without tracking . . . . .                     | 313 |
| 8.5.15 | (TCWU15) – A CANDU-6 type Cartesian cell with burnup . . . . .               | 316 |
| 8.5.16 | (TCWU17) – A 2-D CANDU-6 supercell with control rods . . . . .               | 319 |
| 8.5.17 | (TCWU17Lib) – Microlib definition. . . . .                                   | 325 |
| 8.5.18 | (TCWU31) – Compo-based two group burnup of a CANDU-6 type cell. . . . .      | 327 |
| 8.5.19 | (TCWU05Lib) – Microlib definition. . . . .                                   | 330 |
| 8.6    | Depletion chain examples . . . . .   | 333 |
| 8.7    | Assert procedures . . . . .  | 336 |
| 9      | THE DRAGON PACKAGE . . . . .   | 339 |
| 10     | THE GAN GENERALIZED DRIVER . . . . .   | 344 |
| 11     | THE CLE-2000 CONTROL LANGUAGE . . . . .                                      | 346 |
|        | References . . . . .   | 348 |
|        | Index . . . . .  | 355 |



## List of Figures

|    |   |     |
|----|---|-----|
| 1  | Hexagonal geometry with triangular mesh containing 4 concentric hexagon . . . . .           | 34  |
| 2  | Diagonal boundary conditions in Cartesian geometry . . . . .                                | 37  |
| 3  | Various boundary conditions in Cartesian geometry . . . . .                                 | 38  |
| 4  | Translation/rotation boundary conditions in Cartesian geometry . . . . .                    | 38  |
| 5  | Representing a checkerboard in Cartesian geometry . . . . .                                 | 39  |
| 6  | Hexagonal geometries of type S30 and SA60 . . . . .   | 39  |
| 7  | Hexagonal geometries of type SB60 and S90 . . . . .   | 40  |
| 8  | Hexagonal geometries of type R120 and R180 . . . . .  | 40  |
| 9  | Hexagonal geometry of type SA180 . . . . .  | 41  |
| 10 | Hexagonal geometry of type SB180 . . . . .  | 41  |
| 11 | Hexagonal geometry of type COMPLETE . . . . .   | 42  |
| 12 | Cylindrical correction in Cartesian geometry . . . . .                                      | 42  |
| 13 | Definition of the radii in a CARCEL- or HEXCEL-type geometry . . . . .                      | 46  |
| 14 | Numerotation of the sectors in a Cartesian cell . . . . .                                   | 48  |
| 15 | Numerotation of the sectors in an hexagonal cell . . . . .                                  | 49  |
| 16 | Hexagonal geometry with triangular mesh that extends past the hexagonal boundary . . . . .  | 49  |
| 17 | Description of the various rotations allowed for Cartesian geometries . . . . .             | 56  |
| 18 | Description of the various rotation allowed for hexagonal geometries . . . . .              | 57  |
| 19 | Typical cluster geometry . . . . .  | 57  |
| 20 | Organization of a multicompo object. . . . .  | 131 |
| 21 | Parameter tree in a MULTICOMPO object . . . . .   | 131 |
| 22 | Global parameter tree in a SAPHYB object . . . . .  | 148 |
| 23 | Definition of geometries used by the BREF: module . . . . .                                 | 181 |
| 24 | Equivalent ERM-NEM reflector for the BEAVRS benchmark . . . . .                             | 182 |
| 25 | Cycling tracking over a Cartesian domain. . . . .   | 209 |
| 26 | Cycling tracking over an hexagonal domain. . . . .  | 210 |
| 27 | Slab geometry with mesh-splitting . . . . .   | 235 |
| 28 | Two-dimensional Cartesian assembly containing micro-structures . . . . .                    | 235 |
| 29 | Cylindrical cluster geometry . . . . .  | 236 |
| 30 | Two-dimensional hexagonal geometry . . . . .  | 237 |
| 31 | Three-dimensional Cartesian super-cell . . . . .  | 238 |
| 32 | Hexagonal multicell lattice geometry . . . . .  | 239 |
| 33 | Geometry for test case (TCM01) for an annular cell with macroscopic cross sections. . . . . | 244 |
| 34 | Geometry for test case (TCM02). . . . .   | 246 |
| 35 | Geometry for test case (TCM03). . . . .   | 248 |
| 36 | Geometry of the CANDU-6 supercell with stainless steel rods. . . . .                        | 253 |
| 37 | Geometry of a 2-D hexagonal assembly filled with triangular/hexagonal cells. . . . .        | 274 |
| 38 | Geometry for the Mosteller benchmark problem. . . . .                                       | 277 |
| 39 | Geometry for test case (TCWU02). . . . .  | 280 |
| 40 | Geometry for test case (TCWU03). . . . .  | 284 |
| 41 | Depletion chain of heavy isotopes. . . . .  | 287 |
| 42 | Geometry of the CANDU-6 cell. . . . .   | 291 |
| 43 | Geometry of 2-D CANDU-6 supercell with control rods. . . . .                                | 319 |
| 44 | An example of depletion chain. . . . .  | 334 |
| 45 | Distribution content. . . . .   | 339 |
| 46 | An example of an associative table. . . . .   | 344 |

## List of Tables

|    |   |     |
|----|---|-----|
| 1  | Structure ( <b>DRAGON</b> )                                     | 3   |
| 2  | Structure ( <b>MAC:</b> )                                       | 9   |
| 3  | Structure ( <b>descmacinp</b> )                                 | 10  |
| 4  | Structure ( <b>descxs</b> )                                     | 12  |
| 5  | Structure ( <b>descmacupd</b> )                                 | 15  |
| 6  | Structure ( <b>LIB:</b> )                                       | 16  |
| 7  | Structure ( <b>desclib</b> )                                    | 16  |
| 8  | Structure ( <b>desclib</b> )                                    | 17  |
| 9  | Structure ( <b>desclib</b> )                                    | 17  |
| 10 | Structure ( <b>desclib</b> )                                    | 17  |
| 11 | Structure ( <b>descdepl</b> )                                   | 23  |
| 12 | Structure ( <b>descdeplA2</b> )                                 | 24  |
| 13 | Structure ( <b>descmix1</b> )                                   | 25  |
| 14 | Structure ( <b>descmix2</b> )                                   | 29  |
| 15 | Structure ( <b>GEO:</b> )                                       | 31  |
| 16 | Structure ( <b>descgtyp</b> )                                   | 31  |
| 17 | Structure ( <b>descgcnt</b> )                                   | 32  |
| 18 | Structure ( <b>descBC</b> )                                     | 35  |
| 19 | Structure ( <b>descSP</b> )                                     | 43  |
| 20 | Structure ( <b>descPP</b> )                                     | 50  |
| 21 | Structure ( <b>descDH</b> )                                     | 61  |
| 22 | Structure ( <b>descSIJ</b> )                                    | 62  |
| 23 | Structure ( <b>desctrack</b> )                                  | 64  |
| 24 | Structure ( <b>SYBILT:</b> )                                    | 65  |
| 25 | Structure ( <b>descsybil</b> )                                  | 65  |
| 26 | Structure ( <b>EXCELT:</b> )                                    | 68  |
| 27 | Structure ( <b>descexcel</b> )                                  | 68  |
| 28 | Structure ( <b>NXT:</b> )                                       | 72  |
| 29 | Structure ( <b>descnxt</b> )                                    | 72  |
| 30 | Structure ( <b>MCCGT:</b> )                                     | 77  |
| 31 | Structure ( <b>descmccg</b> )                                   | 77  |
| 32 | Structure ( <b>SNT:</b> )                                       | 80  |
| 33 | Structure ( <b>descsn</b> )                                     | 80  |
| 34 | Structure ( <b>BIVACT:</b> )                                    | 84  |
| 35 | Structure ( <b>descbivac</b> )                                  | 84  |
| 36 | Structure ( <b>TRIVAT:</b> )                                    | 87  |
| 37 | Structure ( <b>descTRIVAC</b> )                                 | 87  |
| 38 | Structure ( <b>ASM:</b> )                                       | 89  |
| 39 | Structure ( <b>descasm</b> )                                    | 89  |
| 40 | Structure ( <b>FLU:</b> )                                       | 92  |
| 41 | Structure ( <b>descflu</b> )                                    | 93  |
| 42 | Structure ( <b>descleak</b> ) in fundamental mode condition     | 95  |
| 43 | Structure ( <b>descleak</b> ) in non-fundamental mode condition | 95  |
| 44 | Structure ( <b>EDI:</b> )                                       | 99  |
| 45 | Structure ( <b>descedi</b> )                                    | 100 |
| 46 | Structure ( <b>EVO:</b> )                                       | 111 |
| 47 | Structure ( <b>descevo</b> )                                    | 111 |
| 48 | Structure ( <b>SPH:</b> )                                       | 117 |
| 49 | Structure ( <b>descsph</b> )                                    | 118 |
| 50 | Structure ( <b>CFC:</b> )                                       | 123 |
| 51 | Structure ( <b>descfc</b> )                                     | 124 |
| 52 | Structure ( <b>INFO:</b> )                                      | 126 |
| 53 | Structure ( <b>info</b> )                                       | 126 |

|     |  |     |
|-----|--|-----|
| 54  | Structure for merging EXCELT: tracks           | 129 |
| 55  | Structure for merging NXT: tracks              | 129 |
| 56  | Structure for partitioning NXT: tracking files | 129 |
| 57  | Structure (descmrg)                            | 130 |
| 58  | Structure (descextr)                           | 130 |
| 59  | Structure (COMPO:)                             | 132 |
| 60  | Structure (compo_data1)                        | 133 |
| 61  | Structure (compo_data2)                        | 136 |
| 62  | Structure (compo_data3)                        | 137 |
| 63  | Structure (compo_data4)                        | 138 |
| 64  | Structure (TLM:)                               | 139 |
| 65  | Structure (desctlm)                            | 139 |
| 66  | Structure (M2T:)                               | 142 |
| 67  | Structure (M2T_data)                           | 142 |
| 68  | Structure (CHAB:)                              | 144 |
| 69  | Structure (CHAB_data)                          | 144 |
| 70  | Structure (CPO:)                               | 146 |
| 71  | Structure (descppo)                            | 146 |
| 72  | Structure (SAP:)                               | 149 |
| 73  | Structure (saphyb_data1)                       | 150 |
| 74  | Structure (saphyb_data2)                       | 152 |
| 75  | Structure (saphyb_data3)                       | 153 |
| 76  | Structure (MPO:)                               | 155 |
| 77  | Structure (mpo_data1)                          | 157 |
| 78  | Structure (mpo_data2)                          | 159 |
| 79  | Structure (mpo_data3)                          | 160 |
| 80  | Group /flux/ of the MPO file                   | 161 |
| 81  | Structure (MC:)                                | 162 |
| 82  | Structure (MC_data)                            | 162 |
| 83  | Structure (T:)                                 | 164 |
| 84  | Structure (DMAC:)                              | 165 |
| 85  | Structure (DMAC_data)                          | 165 |
| 86  | Structure (SENS:)                              | 167 |
| 87  | Structure (SENS_data)                          | 167 |
| 88  | Structure (DUO:)                               | 169 |
| 89  | Structure (DUO_data)                           | 169 |
| 90  | Structure (S2M:)                               | 172 |
| 91  | Structure (S2M_data)                           | 172 |
| 92  | Structure (FMT:) for SUS3D option              | 173 |
| 93  | Structure (FMT:) for DIRFLX option             | 173 |
| 94  | Structure (FMT:) for BURNUP option             | 173 |
| 95  | Structure (FMAC:)                              | 175 |
| 96  | Structure (FMAC_data)                          | 175 |
| 97  | Structure (PSOUR:)                             | 176 |
| 98  | Structure (PSOUR_data)                         | 176 |
| 99  | Structure (HEAT:)                              | 179 |
| 100 | Structure (HEAT_data)                          | 179 |
| 101 | Structure (BREF:)                              | 182 |
| 102 | Structure (BREF_data)                          | 183 |
| 103 | Structure (PSP:)                               | 185 |
| 104 | Structure (descpsp)                            | 185 |
| 105 | Structure (CLM:)                               | 187 |
| 106 | Structure (descclm)                            | 187 |
| 107 | Structure (SHI:)                               | 189 |
| 108 | Structure (descshi)                            | 189 |

|     |                                 |     |
|-----|---------------------------------|-----|
| 109 | Structure ( <b>TONE:</b> )      | 192 |
| 110 | Structure ( <b>desctone</b> )   | 192 |
| 111 | Structure ( <b>USS:</b> )       | 194 |
| 112 | Structure ( <b>descuss</b> )    | 195 |
| 113 | Structure ( <b>AUTO:</b> )      | 198 |
| 114 | Structure ( <b>descauto</b> )   | 199 |
| 115 | Structure ( <b>VDG:</b> )       | 202 |
| 116 | Structure ( <b>descvdg</b> )    | 202 |
| 117 | Structure ( <b>G2S:</b> )       | 204 |
| 118 | Structure ( <b>G2S_data</b> )   | 205 |
| 119 | Structure ( <b>G2MC:</b> )      | 207 |
| 120 | Structure ( <b>G2MC_data</b> )  | 207 |
| 121 | Structure ( <b>SALT:</b> )      | 209 |
| 122 | Structure ( <b>descsalt</b> )   | 210 |
| 123 | Structure ( <b>equality</b> )   | 214 |
| 124 | Structure ( <b>UTL:</b> )       | 215 |
| 125 | Structure ( <b>HUTL:</b> )      | 217 |
| 126 | Structure ( <b>DELETE:</b> )    | 219 |
| 127 | Structure ( <b>BACKUP:</b> )    | 220 |
| 128 | Structure ( <b>RECOVER:</b> )   | 221 |
| 129 | Structure ( <b>ADD:</b> )       | 222 |
| 130 | Structure ( <b>MPX:</b> )       | 223 |
| 131 | Structure ( <b>STAT:</b> )      | 224 |
| 132 | Structure ( <b>GREP:</b> )      | 225 |
| 133 | Structure ( <b>MSTR:</b> )      | 227 |
| 134 | Structure ( <b>FIND0:</b> )     | 229 |
| 135 | Structure ( <b>ABORT:</b> )     | 230 |
| 136 | Structure ( <b>END:</b> )       | 231 |
| 137 | Structure ( <b>DRVMPI:</b> )    | 232 |
| 138 | Structure ( <b>SNDMPI:</b> )    | 233 |
| 139 | Structure <i>assertS</i>        | 336 |
| 140 | Structure <i>assertV</i>        | 336 |
| 141 | Structure ( <b>descmodule</b> ) | 344 |
| 142 | Structure ( <b>descobject</b> ) | 345 |

## 1 INTRODUCTION

The computer code DRAGON is a lattice code designed around solution techniques of the neutron transport equation.<sup>[1]</sup> The DRAGON project results from an effort made at *École Polytechnique de Montréal* to rationalize and unify into a single code the different models and algorithms used in a lattice code.<sup>[2-5]</sup> One of the main concerns was to ensure that the structure of the code was such that the development and implementation of new calculation techniques would be facilitated. DRAGON is therefore a lattice cell code which is divided into many calculation modules linked together around the Ganlib kernel and can be called from CLE-2000.<sup>[6,7]</sup> These modules exchange informations only via well defined data structures.

The two main components of the code DRAGON are its multigroup flux solver and its one-group collision probability (CP) tracking modules. The CP modules all perform the same task but using different levels of approximation.

The SYBIL tracking option emulates the main flux calculation option available in the APOLLO-1 code,<sup>[8,19]</sup> and includes a new version of the EURYDICE-2 code which performs reactor assembly calculations in both rectangular and hexagonal geometries using the interface current method. The option is activated when the SYBILT: module is called.

The EXCELL tracking option is used to generate the collision probability matrices for the cases having cluster, two-dimensional or three-dimensional mixed rectangular and cylindrical geometries.<sup>[21,22]</sup> A cyclic tracking option is also available for treating specular boundary conditions in two-dimensional rectangular geometry.<sup>[26,29]</sup> EXCELL calculations are performed using the EXCELTT: or NXT: module.

The MCCG tracking option activates the long characteristics solution technique. This implementation uses the same tracking as EXCELL and perform flux integration using the long characteristics algorithm proposed by Igor Suslov.<sup>[23-25]</sup> The option is activated when both EXCELTT: (or NXT:) and MCCGT: modules are called.

After the collision probability or response matrices associated with a given cell have been generated, the multigroup solution module can be activated. This module uses the power iteration method and requires a number of iteration types.<sup>[35]</sup> The thermal iterations are carried out by DRAGON so as to rebalance the flux distribution only in cases where neutrons undergo up-scattering. The power iterations are performed by DRAGON to solve the fixed source or eigenvalue problem in the cases where a multiplicative medium is analyzed. The effective multiplication factor ( $K_{\text{eff}}$ ) is obtained during the power iterations. A search for the critical buckling may be superimposed upon the power iterations so as to force the multiplication factor to take on a fixed value.<sup>[36]</sup>

DRAGON can access directly standard microscopic cross-section libraries in various formats. It has the capability of exchanging macroscopic cross-section libraries with a code such as TRANSX-CTR or TRANSX-2 by the use of GOXS format files.<sup>[37,40]</sup> The macroscopic cross section can also be read in DRAGON via the input data stream.

## 2 GENERAL STRUCTURE OF THE DRAGON INPUT

The input to DRAGON is set up in the form of a structure containing commands which call successively each of the calculation modules required in a given transport calculation.

### 2.1 Data organization

The structure of the input data is independent of the physical or computational characteristics of the host system. The physical characteristics of the input data is a collection of sequential records. These characters are by necessity ASCII characters. The logical organization of an input deck is in the form of a sequential structure of input variables presented in free format. This structure must be located in the first 72 columns of each record in the input stream. Characters located in column 73 and  $\leq 132$  can be used to identify the records and are treated as comments. An input variable can be defined in one of two ways.

- As a set of consecutive characters containing no blanks; it will be considered by DRAGON automatically as being either an integer, a real or a character variable depending on the format of the input variable.
- As a set of characters enclosed between quotation marks (''). In this case, the input variable is always considered to be a character variable.

The only separator allowed between two input variables is a single or a set of blanks (not enclosed between quotation marks). A single input variable cannot span two records. Comments can be included in the input deck in one of the following ways:

- characters in column 73 and  $\leq 132$  on each record are considered to be comments;
- all the information following the ';' keyword on a record are not considered by the generalized driver;
- each record starting with the characters '\*' is considered to be commented out;
- all the characters on a given record inserted between '('\*' and '\*'' are considered to be commented out.

This users guide was written using the following conventions:

- An input structure represents a set of input variables. It is identified by a name in boldface surrounded by parenthesis. For example, the complete DRAGON input deck is represented by the structure (**DRAGON**);
- A standard DRAGON data structure represents a set records and directory stored in a hierarchical format on a direct access XSM file or in memory via a linked list.<sup>[41]</sup> It is identified by a name in small capital letter. For example, the data structure ASMPIJ contains the multigroup collision probability matrices generated by the ASM: module of DRAGON;
- The variables presented using the typewriter font are character variables used as keywords. For example **GE0**: is the keyword required to activate the geometry reading module of DRAGON.
- The variables in italics are user defined variables. When indexed and surrounded by parenthesis they denote arrays. If they are in lower case they represent either integer type (starting with *i* to *n*) or real type (starting with *a* to *h* or *o* to *z*) variables. If they are in upper case they represent character type variables. For example, *iprint* must be replaced in the input deck by an integer variable, (*energy*(igroup), igroup=1,*ngroup*+1) states that a vector containing *ngroup*+1 real elements is to be read while *FILE* must be replaced by a character variable, its maximum size being generally specified. No character variable can exceed 72 character in length.
- The variables or structures surrounded by single square brackets '['] are optional.

- The variables or structures surrounded by double square brackets ‘[[ ]]’ are also optional. However, they can be repeated as many times as required.
- The variables or structures surrounded by braces and separated by vertical bars ‘{ | }’ represents various calculation options available in DRAGON. Only one of these options is permitted.

When a fixed default value is specified for an optional parameter in a structure, it can be modified only locally and is reset to the original default value each time the module is called. When a floating default value is specified for a variable, it is saved and can be used in later calls to this module. In DRAGON, almost every default value is a floating value, with the exception of the parameter *iprint*, which is set to 1 and is used to control the amount of information printed in the module. Departure from this general rule will be indicated in the following sections.

## 2.2 DRAGON Data Structure and Module Declarations

DRAGON is built around the Ganlib kernel and its modules can be called from CLE-2000.<sup>[6,7]</sup> Accordingly, all the modules that will be used during the current execution must be first identified. One must also define the format of each data structure that will be processed by these modules. Then, the modules required for the specific DRAGON calculation are called successively, information being transferred from one module to the next via the data structures. Finally, the execution of DRAGON is terminated when it encounters the END: module even if it is followed by additional data records in the input data stream. The general input data structure therefore follows the calling specifications given below:

Table 1: Structure (**DRAGON**)

```
[ MODULE [[ MODNAME ]] ; ]
[ LINKED_LIST [[ STRNAME ]] ; ]
[ XSM_FILE [[ STRNAME ]] ; ]
[ SEQ_BINARY [[ STRNAME ]] ; ]
[ SEQ_ASCII [[ STRNAME ]] ; ]
[[ (module) ; ]]
END: ;
```

where

|             |  |
|-------------|--|
| MODULE      | keyword used to specify the list of modules to be used in this DRAGON execution.   |
| MODNAME     | <b>character*12</b> name of a DRAGON or utility module. The list of DRAGON module is provided in Section 2.3 while the list of Utility module is described in Section 2.4. By default a ‘ ’ module is always available (see Sections 2.4 and 6.1). |
| LINKED_LIST | keyword used to specify which data structures will be stored in linked lists.  |
| XSM_FILE    | keyword used to specify which data structures will be stored on XSM format files.  |
| SEQ_BINARY  | keyword used to specify which data structures will be stored on sequential binary files.   |
| SEQ_ASCII   | keyword used to specify which data structures will be stored on sequential ASCII files.  |
| STRNAME     | <b>character*12</b> name of a DRAGON data structure. Note that on MVS file names are truncated to 7 characters due to a constraint of this operating system. The list of DRAGON data structure is presented in Section 2.5.                        |
| (module)    | input specifications for a DRAGON or utility module. For the DRAGON specific modules these input structures will be defined in Section 3. For utility modules, the required structures are described in Section 6.                                 |

**END:** keyword to call the normal end-of-execution utility module.

**;** end of record keyword. This keyword is used by DRAGON to delimit the part of the input data stream associated with each module.

Note that the user generally has the choice to declare most of the data structures in the format of a linked list to reduce CPU times or as a XSM file to reduce memory resources. Some exceptions to this general rule are the tracking files as we will see in Section 3.4. In general, the data structure are stored on the sequential ASCII files only for backup purposes.

The input data normally ends with a call to the **END:** module (see Section 6.14). However, the GAN driver will insert automatically the **END:** module, even if it was not provided, upon reaching an end-of-file in the input stream.

Each (**module**) specification contains a description of the execution modules to be called and its associated input structure. All these modules, except the **END:** module may be called more than once.

### 2.3 The DRAGON Modules

The code DRAGON has been divided into main calculations sequences to which is generally associated a single calculation module. The only exception to this rule is the tracking sequence to which is associated many different modules, one for each of the standard CP calculation options and an additional module for diffusion calculations. However, this later module can only be used indirectly in the edition module of DRAGON. These modules perform the following tasks:

**MAC:** module used to generate or modify a DRAGON MACROLIB (see Section 2.5) which contains the group ordered macroscopic cross sections for a series of mixture (see Section 3.1). This MACROLIB can be either an independent data structure or it can be included as a substructure in a MICROLIB. The spatial location of these mixtures will be defined using the **GEO:** module (see Section 3.3).

**LIB:** module used to generate or modify a DRAGON MICROLIB (see Section 2.5) that can read a number of different types of microscopic cross-section libraries (see Section 3.2). Each such access requires a double interpolation (temperature, dilution) carried out by a subroutine specifically tailored to each type of library. Currently the formats DRAGLIB<sup>[41]</sup>, WIMS-D4<sup>[39]</sup>, MATXS<sup>[37]</sup>, WIMS-AECL<sup>[38]</sup>, APOLLO<sup>[8,9]</sup> and NDAS format<sup>[11]</sup> are supported. After having reconstructed the microscopic cross sections for each isotope, they are then multiplied by the isotopic concentrations (particles per  $cm^3$ ) and combined in such a way as to produce an embedded MACROLIB (see Section 2.5). The spatial location of these mixtures will be defined using the **GEO:** module (see Section 3.3).

**GEO:** module used to generate or modify a geometry (see Section 3.3).

**SYBILT:** the standard tracking module based on 1D collision probability or Interface Current technique (see Section 3.4 and Section 3.4.1).

**EXCELT:** the standard tracking module for 2D and 3D geometries as well as isolated 2D cells containing clusters (see Section 3.4 and Section 3.4.2).

**NXT:** the standard tracking module for 2D or 3D assemblies of cluster (see Section 3.4 and Section 3.4.3).

**SNT:** the discrete ordinates tracking module (see Section 3.4 and Section 3.4.5).

**MCCGT:** the tracking module of the open characteristics flux solver (see Section 3.4 and Section 3.4.4).

**BIVACT:** the 1D/2D diffusion and  $SP_n$  tracking module (see Section 3.4 and Section 3.4.6).

**TRIVAT:** the 1D/2D/3D diffusion and  $SP_n$  tracking module (see Section 3.4 and Section 3.4.7).



|        |  |
|--------|--|
| SHI:   | module used to perform self-shielding calculations based on the generalized Stamm'ler method (see Section 4.1).  |
| TONE:  | module used to perform self-shielding calculations based on the Tone's method (see Section 4.2).   |
| USS:   | module used to perform self-shielding calculations based on a subgroup method (see Section 4.3). A method using physical probability tables (cf. Wims-7 and Helios) and the Ribon extended method are available. |
| AUTO:  | module used to perform self-shielding calculations based on the Autosecol method (see Section 4.4).  |
| ASM:   | module which uses the tracking information to generate a multigroup response or collision probability matrix (see Section 3.5).  |
| FLU:   | module which uses inner-iteration approach or collision probability matrix to solve the transport equation for the fluxes (see Section 3.6). Various leakage models are available.                               |
| EDI:   | editing module (see Section 3.7). An equivalence method based on SPH method is available.  |
| EVO:   | burnup module (see Section 3.8).   |
| SPH:   | <i>supermomogénéisation</i> (SPH) module (see Section 3.9). The SPH: module can also be used to extract a MICROLIB or MACROLIB from a MULTICOMPO or SAPHYB.  |
| INFO:  | utility to compute number densities for selected isotopes in materials such as UO <sub>2</sub> or ThUO <sub>2</sub> (see Section 3.11).  |
| COMPO: | multi-parameter reactor database construction module (see Section 3.13).   |
| TLM:   | module used to generate a Matlab M-file to obtain a graphics representation of the NXT: tracking lines (see Section 3.14).   |
| M2T:   | interface module for transforming a macrolib into a Trimaran/Tripoli multigroup file (see Section 3.15).   |
| CHAB:  | cross section perturbation module similar to CHABINT (see Section 3.16).   |
| CPO:   | burnup-dependent mono-parameter reactor database construction module (see Section 3.17).   |
| SAP:   | multi-parameter reactor database construction module in SAPHYB format (see Section 3.18).  |
| MPO:   | multi-parameter reactor database construction module in MPO format (see Section 3.19).   |
| MC:    | multigroup Monte-Carlo flux solution module (see Section 3.20).  |
| T:     | macrolib transposition operator (see Section 3.21).  |
| DMAC:  | construction module for a Generalized Perturbation Theory (GPT) source (see Section 3.22).   |
| SENS:  | sensitivity analysis of keff to nuclear data (see Section 3.23).   |
| PSP:   | module to generate PostScript images for 2D geometries that can be tracked using the module EXCELT: or NXT: (see Section 3.31).  |
| DUO:   | module to perform a perturbative analysis of two systems using the Clio formula and to determine the origins of Keff discrepancies (see Section 3.24).   |

## 2.4 The Utility Modules

Because the execution of DRAGON is controlled by the GAN generalized driver it can use directly any one of its utility modules. These modules perform the following tasks:

|          |   |
|----------|---|
| ' '      | default module used to make an explicit copy of a data structure (see Section 6.1).                       |
| UTL:     | module used to manipulate a LCM or XSM data structure (see Section 6.2).                                  |
| HUTL:    | module used to manipulate a HDF5 file (see Section 6.3).  |
| DELETE:  | module used to delete a data structure (see Section 6.4).   |
| BACKUP:  | module used to make a backup copy of a child data structure along with its parent (see Section 6.5).      |
| RECOVER: | module used to recover from a backup copy a child data structure along with its parent (see Section 6.6). |
| ADD:     | module used to add two data structures (see Section 6.7).   |
| MPX:     | module used to multiply a data structure by a constant (see Section 6.8).                                 |
| STAT:    | module used to compare two data structures (see Section 6.9).   |
| GREP:    | module used to locate information on a data structure (see Section 6.10).                                 |
| FINDO:   | module used to find the zero of a tabulated function (see Section 6.12).                                  |
| END:     | module used to terminate an execution controlled by the generalized driver (see Section 6.14).            |

## 2.5 The DRAGON Data Structures

The transfer of information between the DRAGON execution modules is ensured by well defined data structure. They are generally created or modified directly by one of the modules of DRAGON or by one of the utility modules. Here we will give a brief description of these data structures but a more complete description of their content is also available upon request.<sup>[41]</sup> These data structures are memory-resident or persistent (i.e., XSM-type) objects.

|          |  |
|----------|--|
| MACROLIB | a standard data structure used by DRAGON to transfer group-ordered macroscopic cross sections between its modules. It can be a stand-alone structure or it can be included into a larger structure, such as a MICROLIB or an EDITION structure. It can be created by the MAC:, LIB: and EDI: modules. It can also be modified by a resonance self-shielding module (SHI:, TONE:, USS:, AUTO:) or by a depletion calculation in module EVO:. Such a structure (either stand-alone or as part of a MICROLIB) is also required for a successful execution of the ASM: and FLU: modules. |
| MICROLIB | a standard data structure used by DRAGON to transfer microscopic and macroscopic cross sections between its modules. It may include a MACROLIB substructure. It can be a stand-alone structure or included into a larger structure, such as an EDITION structure or a multi-parameter structure. It can be created by the LIB: and EDI: modules. It can also be modified by module MAC: or by a resonance self-shielding module.   |
| GEOMETRY | a standard data structure used by DRAGON to transfer the geometry between its modules. It can be a stand-alone structure or included into a larger structure, such as another GEOMETRY structure. It can be created by the GEO: module. Such a structure is also required directly for a successful execution of the tracking modules (SYBILT:, EXCELT: and MCCGT:).   |

|            |   |
|------------|---|
| TRACKING   | a standard data structure used by DRAGON to transfer the general tracking information between its modules. It is a stand-alone structure. It can be created by the SYBILT:, EXCELT: and MCCGT: modules. Such a structure is also required directly for a successful execution of the ASM: module.   |
| ASMPIJ     | a standard data structure used by DRAGON to transfer the multigroup response and collision probability matrices between its modules. It is a stand-alone structure. It is created by the ASM: module. Such a structure is also required directly for a successful execution of the FLU: module.   |
| FLUXUNK    | a standard data structure used by DRAGON to transfer the fluxes between its modules. It is a stand-alone structure. It is created by the FLU: module. Such a structure is also required for a successful execution of the EDI: and EVO: modules.  |
| EDITION    | a standard data structure used by DRAGON to store condensed and merged microscopic and macroscopic cross sections. It is a stand-alone structure but can contain MACROLIB and MICROLIB substructure. It is created by the EDI: module. Such a structure is also required for a successful execution of the COMPO: module.                 |
| BURNUP     | a standard data structure used by DRAGON to store burnup informations. It is created by the EVO: module. Such a structure is also required for a successful execution of the COMPO: module.   |
| DRAGLIB    | a standard data structure used by DRAGON (input) to recover isotopic-, dilution- and temperature-dependent information, including multigroup microscopic cross sections and burnup data. This is a stand-alone structure that is generally stored on a persistent LCM object. It may be created by the <code>dragr</code> module of NJOY. |
| CPO        | a standard data structure used by DRAGON to store a simplified reactor database. It is a stand-alone structure that must be stored on a linked list or an XSM file. It is created by the CPO: module. It is required for a successful execution of the CFC: module. It can be used by the CRE: module of DONJON.                          |
| MULTICOMPO | a standard data structure used by DRAGON (output) to store reactor related information and to classified it using tuples of local and global parameters. This is a stand-alone structure that is generally stored on a persistent LCM object. It is created by the COMPO: module.   |
| SAPHYB     | a standard data structure used by APOLLO2 and DRAGON (output) to store reactor related information and to classified it using tuples of global parameters. This is a stand-alone structure that is generally stored on a persistent LCM object. It is created by the SAP: module.   |
| FBMXSDB    | a standard data structure used by DRAGON to store a full reactor cross section database with Feedback coefficients. It is a stand-alone structure that must be stored on a linked list or an XSM file. It is created by the CFC: module. It can be used by the AFM: module of DONJON. <sup>[100]</sup>                                    |

## 2.6 Main Updates in DRAGON

The frozen version (DRAGON Release 3.06) has seen a large number of changes since the first official release of the code (DRAGON\_960627).

The following DRAGON package (DRAGON Version4) is an evolution of the frozen version, released as an attempt to introduce innovative capabilities:

- The self-shielding module `USS:` allow increased accuracy and better representation of phenomena such as *distributed self-shielding effects* and *mutual self-shielding effects*.
- The new flux solution solver `MCCG` is an implementation of the long characteristics method proposed by Igor Suslov. This solver is initiated by the new tracking module `MCCGT:`.

- The new flux solution module **FLU**: is a complete rewrite of the outer iteration for the multigroup flux calculation that is now compatible with the method of characteristics and with any other approach requiring inner iterations. The **MOCC**: module is no longer required.
- The burnup module **EVO**: was extended to take into account energy produced by radioactive decay and by reactions other than fission.
- The new module **COMPO**: is used to create and increment a multiparameter reactor database. The module The companion module **NCR**: is used to interpolate an existing multiparameter reactor database.
- The flux solution solver **SYBIL** related to 2D assembly calculations was extended to allow sectorization of the cells.
- The method of discrete ordinates is implemented in tracking module **SNT**:.
- The **EXCELL**: module has been removed, but its capability is now implemented using the **XCLL** keyword in **EXCELT**:.
- The **LIB**: module can access NDAS-formatted cross-section libraries.

The current DRAGON package (DRAGON Version5) is a rewrite of the code around the GANLIB5 kernel<sup>[6]</sup>, intended to be 64-bit clean.

### 3 THE DRAGON MODULES

The input to DRAGON is set up in the form of a structure containing commands which call successively each of the calculation modules required in a given transport calculation.

#### 3.1 The MAC: module

In DRAGON, the macroscopic cross sections associated with each mixture are stored in a MACROLIB (as an independent data structure or as part of a MICROLIB) which may be generated using one of different ways:

- First, one can use directly the input stream already used for the remaining DRAGON data. In this case, a single macroscopic library is involved.
- The second method is via a GOXS format binary sequential file.<sup>[37]</sup> It should be noted that a number of GOXS files may be read successively by DRAGON and that it is possible to combine data from GOXS files with data taken from the input stream. One can also transfer the macroscopic cross sections to a GOXS format binary file if required. In this case, a single macroscopic library is involved.
- The third input method is through a file which already contains a MACROLIB. In this case, two macroscopic and microscopic libraries are to be combined
- The fourth method consists to update an existing MACROLIB using control-variable data recovered from a L\_OPTIMIZE object.

The general format of the data for the MAC: module is the following:

Table 2: Structure (MAC:)

```
{ MACLIB := MAC: [ MACLIB ] :: (descmacinp)
  | MICLIB := MAC: MICLIB :: (descmacinp)
  | MACLIB := MAC: [ MACLIB ] [ OLDLIB ] :: (descmacupd)
  | MACLIB := MAC: MACLIB OPTIM ;
}
```

The meaning of each of the terms above is:

|                       |   |
|-----------------------|---|
| <i>MACLIB</i>         | <b>character*12</b> name of a MACROLIB that will contain the macroscopic cross sections. If <i>MACLIB</i> appears on both LHS and RHS, it is updated; otherwise, it is created. If <i>MACLIB</i> is created, all macroscopic cross sections are first initialized to zero.  |
| <i>MICLIB</i>         | <b>character*12</b> name of a MICROLIB. Only the MACROLIB data substructure of this MICROLIB is then updated. This is used mainly to associate fixed sources densities with various mixtures. If any other cross section is modified for a specific mixture, the microscopic and macroscopic cross sections are no longer compatible. One can return to a compatible library using the library update module (see Section 3.2). |
| <i>OLDLIB</i>         | <b>character*12</b> name of a MACROLIB or a MICROLIB which will be used to update or create the <i>MACLIB</i> MACROLIB.   |
| <i>OPTIM</i>          | <b>character*12</b> name of a L_OPTIMIZE object. The MACROLIB <i>MACLIB</i> is updated using control-variable data recovered from <i>OPTIM</i> .  |
| ( <b>descmacinp</b> ) | macroscopic input data structure for this module (see Section 3.1.1).   |

(**descmacupd**) macroscopic update data structure for this module (see Section 3.1.3).

### 3.1.1 Input structure for module MAC:

In the case where there are no *OLDLIB* specified, the (**descmac**) input structure takes the form:

Table 3: Structure (**descmacinp**)

```
[ EDIT iprint ]
[ NGRO ngroup ]
[ NMIX nmixt ]
[ NIFI nifiss ]
[ DELP ndel ]
[ ANIS naniso ]
[ NADF nadf ]
[ CTRA { NONE | APOL | WIMS | LEAK } ]
[ ALBP nalbp ((albedp(ig,ia),ig=1,ngroup),ia=1,nalbp) ]
[ WRIT GOXSWN ]
[ ENER (energy(ig), ig=1,ngroup +1) ]
[ VOLUME (volume(ibm), ibm=1,nmixt) ]
[ ADD ]
[[ { READ [ (imat(i), i=1,nmixt) ] GOXSRN [ DELE ] | READ INPUT [[ (descxs) ] ] } ]
[[ STEP istep READ INPUT [[ (descxs) ] ] ]
[ NORM ]
;
```

with

|               |   |
|---------------|---|
| EDIT          | keyword used to modify the print level <i>iprint</i> .  |
| <i>iprint</i> | index used to control the printing in this module. It must be set to 0 if no printing on the output file is required. The macroscopic cross sections can be written to the output file if the variable <i>iprint</i> is greater than or equal to 2. The transfer cross sections will be printed if this parameter is greater than or equal to 3. The normalization of the transfer cross sections will be checked if <i>iprint</i> is greater than or equal to 5. |
| NGRO          | keyword to specify the number of energy groups for which the macroscopic cross sections will be provided. This information is required only if <i>MACLIB</i> is created and the cross sections are taken directly from the input data stream.   |
| <i>ngroup</i> | the number of energy groups used for the calculations in DRAGON. The default value is <i>ngroup</i> =1.   |
| NMIX          | keyword used to define the number of material mixtures. This information is required only if <i>MACLIB</i> is created and the cross sections are taken directly from the input data stream or from a GOXS file.   |
| <i>nmixt</i>  | the maximum number of mixtures (a mixture is characterized by a distinct set of macroscopic cross sections) the MACROLIB may contain. The default value is <i>nmixt</i> =1.   |
| NIFI          | keyword used to specify the maximum number of fission spectrum associated with each mixture. Each fission spectrum generally represents a fissionable isotope. This information   |

is required only if *MACLIB* is created and the cross sections are taken directly from the input data stream.

|               |  |
|---------------|--|
| <i>nifiss</i> | the maximum number of fissile isotopes per mixture. The default value is <i>nifiss</i> =1.   |
| DELP          | keyword used to specify the number of delayed neutron groups.  |
| <i>ndel</i>   | the number of delayed neutron groups. The default value is <i>ndel</i> =0.   |
| ANIS          | keyword used to specify the maximum level of anisotropy permitted in the scattering cross sections. This information is required only if <i>MACLIB</i> is created and the cross sections are taken directly from the input data stream.  |
| <i>naniso</i> | number of Legendre orders for the representation of the scattering cross sections. The default value is <i>naniso</i> =1 corresponding to the use of isotropic scattering cross sections.  |
| NADF          | keyword used to specify the number of averaged fluxes surrounding the geometry and used to compute <i>assembly discontinuity factors</i> (ADF).  |
| <i>nadf</i>   | number of averaged fluxes surrounding the geometry.  |
| CTRA          | keyword to specify the type of transport correction that should be generated and stored on the MACROLIB. The transport correction is to be subtracted from the total and isotropic ( $P_0$ ) within-group scattering cross sections. A leakage correction, equal to the difference between current- and flux-weighted total cross sections ( $\Sigma_1 - \Sigma_0$ ) is also applied in the APOL and LEAK cases. All the modules that will read this MACROLIB will then have access to transport corrected cross sections. The default is no transport correction when the MACROLIB is created from the input or GOXS files. |
| NONE          | keyword to specify that no transport correction should be used in this calculation.  |
| APOL          | keyword to specify that an APOLLO type transport correction based on the linearly anisotropic ( $P_1$ ) scattering cross sections is to be set. This correction assumes that the micro-reversibility principle is valid for all energy groups. $P_1$ scattering information must exist in the MACROLIB.  |
| WIMS          | keyword to specify that a WIMS-type transport correction is used. The transport correction is recovered from a record named TRANC. This record must exist in the MACROLIB.   |
| LEAK          | A leakage correction is applied to the total and $P_0$ within-group scattering cross sections. No transport correction is applied in this case.  |
| ALBP          | keyword used for the input of the multigroup physical albedo array.  |
| <i>nalbp</i>  | the maximum number of multigroup physical albedos.   |
| <i>albedp</i> | multigroup physical albedo array.  |
| WRIT          | keyword used to write cross section data to a GOXS file. In the case where <i>nifiss</i> >1, this option is invalid.   |
| GOXSWN        | <b>character*7</b> name of the GOXS file to be created or updated.   |
| ENER          | keyword to specify the energy group limits.  |
| <i>energy</i> | energy (eV) array which define the limits of the groups ( <i>ngroup</i> +1 elements). Generally <i>energy</i> (1) is the highest energy.   |
| VOLUME        | keyword to specify the mixture volumes.  |
| <i>volume</i> | volume (cm <sup>3</sup> ) occupied by each mixture.  |

|                   |  |
|-------------------|--|
| ADD               | keyword for adding increments to existing macroscopic cross sections. In this case, the information provided in ( <b>descxs</b> ) represents incremental rather than standard cross sections.  |
| READ              | keyword to specify the input file format. One can use either the input stream (keyword INPUT) or a GOXS format file.   |
| <i>imat</i>       | array of mixture identifiers to be read from a GOXS file. The maximum number of identifiers permitted is <i>nmixt</i> and the maximum value that <i>imat</i> may take is <i>nmixt</i> . When <i>imat</i> is 0, the corresponding mixture on the GOXS file is not included in the MACROLIB. In the cases where <i>imat</i> is absent all the mixtures on the GOXS file are available in a DRAGON execution. They are numbered consecutively starting at 1 or from the last number reached during a previous execution of the MAC: module. |
| GOXSRN            | <b>character*7</b> name of the GOXS file to be read.   |
| DELE              | keyword to specify that the GOXS file is deleted after being read  |
| INPUT             | keyword to specify that mixture cross sections will be read on the input stream.   |
| ( <b>descxs</b> ) | structure describing the format used for reading the mixture cross sections from the input stream (see Section 3.1.2).   |
| STEP              | keyword used to create a perturbation directory.   |
| <i>istep</i>      | the index of the perturbation directory.   |
| NORM              | keyword to specify that the macroscopic scattering cross sections and the fission spectrum have to be normalized. This option is available even if the mixture cross sections were not read by the MAC: module.  |

### 3.1.2 Macroscopic cross section definition

Table 4: Structure (**descxs**)

```

MIX [ matnum ]
  [ { NTOTO | TOTAL } (xssigt(jg), jg=1,ngroup) ]
  [ NTOT1 (xssig1(jg), jg=1,ngroup) ]
  [ TRANC (xsstra(jg), jg=1,ngroup) ]
  [ NUSIGF ((xssigf(jf,jg), jg=1,ngroup), jf=1,nifiss) ]
  [ CHI ((xschi(jf,jg), jg=1,ngroup), jf=1,nifiss) ]
  [ FIXE (xsfixe(jg), jg=1,ngroup) ]
  [ DIFF (diff(jg), jg=1,ngroup) ]
  [ DIFFX (xdiffx(jg), jg=1,ngroup) ]
  [ DIFFY (xdiffy(jg), jg=1,ngroup) ]
  [ DIFFZ (xdiffz(jg), jg=1,ngroup) ]
  [ NUSIGD (((xssigd(jf,idel,jg), jg=1,ngroup), idel=1,ndel), jf=1,nifiss) ]
  [ CHDL (((xschid(jf,idel,jg), jg=1,ngroup), idel=1,ndel), jf=1,nifiss) ]
  [ OVERV (overv(jg), jg=1,ngroup) ]
  [ NFTOT (nftot(jg), jg=1,ngroup) ]
  [ FLUX-INTG (xsint0(jg), jg=1,ngroup) ]
  [ FLUX-INTG-P1 (xsint1(jg), jg=1,ngroup) ]

```

continued on next page



Structure (**descxs**)

continued from last page

```
[ H-FACTOR (hfact(ig), ig=1,ngroup) ]
[ SCAT (( nbscat(jl,ig), ilastg(jl,ig),(xsscat(jl,ig,ig),
          ig=1,nbscat(jl,ig) ), ig=1,ngroup), jl=1,naniso) ]
[[ ADF hadf (xadf(ig), ig=1,ngroup) ]]
```

|               |  |
|---------------|--|
| MIX           | keyword to specify that the macroscopic cross sections associated with a new mixture are to be read.   |
| <i>matnum</i> | identifier for the next mixture to be read. The maximum value permitted for this identifier is <i>nmixt</i> . When <i>matnum</i> is absent, the mixtures are numbered consecutively starting with 1 or with the last mixture number read either on the GOXS or the input stream. |
| NTOTO         | keyword to specify that the total macroscopic cross sections for this mixture follows.   |
| TOTAL         | alias keyword for NTOTO.   |
| <i>xssigt</i> | array representing the multigroup total macroscopic cross section ( $\Sigma^g$ in $\text{cm}^{-1}$ ) associated with this mixture.   |
| NTOT1         | keyword to specify that the $P_1$ -weighted total macroscopic cross sections for this mixture follows.   |
| <i>xssig1</i> | array representing the multigroup $P_1$ -weighted total macroscopic cross section ( $\Sigma_1^g$ in $\text{cm}^{-1}$ ) associated with this mixture.   |
| TRANC         | keyword to specify that the transport correction macroscopic cross sections for this mixture follows.  |
| <i>xsstra</i> | array representing the multigroup transport correction macroscopic cross section ( $\Sigma_{tc}^g$ in $\text{cm}^{-1}$ ) associated with this mixture.   |
| NUSIGF        | keyword to specify that the macroscopic fission cross section multiplied by the average number of neutrons per fission for this mixture follows.   |
| <i>xssigf</i> | array representing the multigroup macroscopic fission cross section multiplied by the average number of neutrons per fission ( $\nu\Sigma_f^g$ in $\text{cm}^{-1}$ ) for all the fissile isotopes associated with this mixture.  |
| CHI           | keyword to specify that the fission spectrum for this mixture follows.   |
| <i>xschi</i>  | array representing the multigroup fission spectrum ( $\chi^g$ ) for all the fissile isotopes associated with this mixture.   |
| FIXE          | keyword to specify that the fixed neutron source density for this mixture follows.   |
| <i>xsfixe</i> | array representing the multigroup fixed neutron source density for this mixture ( $S^g$ in $s^{-1}\text{cm}^{-3}$ ).   |
| DIFF          | keyword to specify that the isotropic diffusion coefficient for this mixture follows.  |
| <i>diff</i>   | array representing the multigroup isotropic diffusion coefficient for this mixture ( $D^g$ in $\text{cm}$ ).   |
| DIFFX         | keyword for input of the $X$ -directed diffusion coefficient.  |
| <i>xdiffx</i> | array representing the multigroup $X$ -directed diffusion coefficient ( $D_x^g$ in $\text{cm}$ ) for the mixture <i>matnum</i> .   |

|               |  |
|---------------|--|
| DIFFY         | keyword for input of the $Y$ -directed diffusion coefficient.  |
| <i>xdiffy</i> | array representing the multigroup $Y$ -directed diffusion coefficient ( $D_y^g$ in cm) for the mixture <i>matnum</i> .   |
| DIFFZ         | keyword for input of the $Z$ -directed diffusion coefficient.  |
| <i>xdiffz</i> | array representing the multigroup $Z$ -directed diffusion coefficient ( $D_z^g$ in cm) for the mixture <i>matnum</i> .   |
| NUSIGD        | keyword to specify that the delayed macroscopic fission cross section multiplied by the average number of neutrons per fission for this mixture follows.   |
| <i>xssigd</i> | array representing the delayed multigroup macroscopic fission cross section multiplied by the average number of neutrons per fission ( $\nu\Sigma_f^{g,idel}$ in $\text{cm}^{-1}$ ) for all the fissile isotopes associated with this mixture.   |
| CHDL          | keyword to specify that the delayed fission spectrum for this mixture follows.   |
| <i>xschid</i> | array representing the delayed multigroup fission spectrum ( $\chi^{g,idel}$ ) for all the fissile isotopes associated with this mixture.  |
| OVERV         | keyword for input of the multigroup average of the inverse neutron velocity.   |
| <i>overv</i>  | array representing the multigroup average of the inverse neutron velocity ( $\langle 1/v \rangle_m^g$ ) for the mixture <i>matnum</i> .  |
| NFTOT         | keyword for input of the multigroup macroscopic fission cross sections.  |
| <i>nftot</i>  | array representing the multigroup macroscopic fission cross section ( $\Sigma_f^g$ ) for the mixture <i>matnum</i> .   |
| FLUX-INTG     | keyword for input of the multigroup $P_0$ volume-integrated fluxes.  |
| <i>xsint0</i> | array representing the multigroup $P_0$ volume-integrated fluxes ( $V\phi_0^g$ ) for the mixture <i>matnum</i> .   |
| FLUX-INTG-P1  | keyword for input of the multigroup $P_1$ volume-integrated fluxes.  |
| <i>xsint1</i> | array representing the multigroup $P_1$ volume-integrated fluxes ( $V\phi_1^g$ ) for the mixture <i>matnum</i> .   |
| H-FACTOR      | keyword to specify that the power factor for this mixture follows.   |
| <i>hfact</i>  | array representing the multigroup power factor for this mixture ( $H^g$ in $\text{MeV cm}^{-1}$ ).   |
| SCAT          | keyword to specify that the macroscopic scattering cross section matrix for this mixture follows.  |
| <i>nbscat</i> | array representing the number of primary groups <i>ig</i> with non vanishing macroscopic scattering cross section towards the secondary group <i>ig</i> considered for each anisotropy level associated with this mixture.   |
| <i>ilastg</i> | array representing the group index of the most thermal group with non-vanishing macroscopic scattering cross section towards the secondary group <i>ig</i> considered for each anisotropy level associated with this mixture.  |
| <i>xsscat</i> | array representing the multigroup macroscopic scattering cross section ( $\Sigma_{sl}^{ig \rightarrow jg}$ in $\text{cm}^{-1}$ ) from the primary group <i>ig</i> towards the secondary group <i>ig</i> considered for each anisotropy level associated with this mixture. The elements are ordered using decreasing primary group number <i>ig</i> , from <i>ilastg</i> to ( <i>ilastg</i> - <i>nbscat</i> + 1), and an increasing secondary group number <i>ig</i> . Examples of input structures for macroscopic scattering cross sections can be found in Section 8.1. |

|             |  |
|-------------|--|
| ADF         | keyword to specify that the boundary flux information for this mixture follows.                            |
| <i>hadf</i> | character*8 type of a flux surrounding the geometry. The maximum number of types is equal to <i>nadf</i> . |
| <i>xadf</i> | array representing a multigroup flux of type <i>hadf</i> surrounding the geometry for this mixture.        |

### 3.1.3 Update structure for operator MAC:

In the case where *OLDLIB* is specified, the (**descmacupd**) input structure takes the form:

Table 5: Structure (**descmacupd**)

```
[ EDIT iprint ]
[ NMIX nmixt ]
[ CTRA OFF ]
[[ MIX numnew [ numold { UPDL | OLDL } ] ] ]
;
```

with

|               |   |
|---------------|---|
| EDIT          | keyword used to modify the print level <i>iprint</i> .  |
| <i>iprint</i> | index used to control the printing in this operator. It must be set to 0 if no printing on the output file is required. The macroscopic cross sections can be written to the output file if the variable <i>iprint</i> is greater than or equal to 2. The transfer cross sections will be printed if this parameter is greater than or equal to 3. The normalization of the transfer cross sections will be checked if <i>iprint</i> is greater than or equal to 5. |
| NMIX          | keyword used to define the number of material mixtures. This information is required only if <i>MACLIB</i> contains more mixtures than <i>OLDLIB</i> .  |
| <i>nmixt</i>  | the maximum number of mixtures (a mixture is characterized by a distinct set of macroscopic cross sections) <i>MACLIB</i> may contain.  |
| CTRA          | keyword to specify the type of transport correction that should be generated and stored on the <i>MACROLIB</i> . All the operators that will read this <i>MACROLIB</i> will then have access to transport corrected cross sections. In the case where the <i>MACROLIB</i> is updated using other <i>MACROLIB</i> or <i>MICROLIB</i> the default is to use a transport correction whenever one of these older data structures requires a transport correction.       |
| OFF           | deactivates the transport correction.   |
| MIX           | keyword to specify that the macroscopic cross sections associated with a mixture is to be created or updated.   |
| <i>numnew</i> | mixture number to be updated or created on the output <i>MACROLIB</i> .   |
| <i>numold</i> | mixture number on an old <i>MACROLIB</i> or <i>MICROLIB</i> which will be used to update or create <i>numnew</i> on the output <i>macrolib</i>  |
| OLDL          | the macroscopic cross sections associated with mixture <i>numold</i> are taken from <i>OLDLIB</i> . This is the default option.   |
| UPDL          | the macroscopic cross sections associated with mixture <i>numold</i> are taken from <i>MACLIB</i> .   |

### 3.2 The LIB: module

The general format of the input data for the LIB: module is the following:

Table 6: Structure (LIB:)

```
MICLIB := LIB: [ MICLIB [ OLDLIB ] ] :: (desclib)
```

where

- MICLIB**      **character\*12** name of the MICROLIB that will contain the internal library. If *MICLIB* appears on both LHS and RHS, it is updated; otherwise, it is created.
- OLDLIB**      **character\*12** name of a read-only MACROLIB, MICROLIB or BURNUP data structure. In the case where a MACROLIB is considered, it is included directly in the *MICLIB* before updating it. If it is a second MICROLIB or a BURNUP data structure, the number densities for the isotopes in file *MICLIB* will be replaced selectively by those found in *OLDLIB*.
- (desclib)**    input structure for this module (see Section 3.2.1).

#### 3.2.1 Data input for module LIB:

In the case where *OLDLIB* is absent or represents a MACROLIB, **(desclib)** takes the form:

Table 7: Structure (desclib)

```
[ EDIT iprint ]
[ NGRO ngroup ]
[ MXIS nmisot ]
[ NMIX nmixt ]
[ CALENDF ipreci ]
[ CTRA { NONE | APOL | WIMS | OLDW | LEAK } ] [ ANIS naniso ]
[ STERN nstern ]
[ ADJ ]
[ PROM ]
[ { SKIP | INTR | SUBG | PT | PTMC | PTSL | RSE [ svdeps ] | NEWL } ] [ MACR ]
[ ADED nedit ( HEDIT(i), i=1,nedit ) ]
[ DEPL { LIB: { DRAGON | WIMSD4 | WIMSE | WIMSAECL | NDAS | APLIB3 } FIL: NAMEFIL
  | LIB: { APLIB2 | APXSM } FIL: NAMEFIL (descdeplA2)
  | ndepl (descdepl) } ]
[[ MIXS LIB:
  { DRAGON | MATXS | MATXS2 | WIMSD4 | WIMSE | WIMSAECL | NDAS | APLIB1 | APLIB2
  | APXSM | APLIB3 | MICROLIB }
  FIL: NAMEFIL [[ (descmix1) ] ] ]]
```

It is possible to reset an existing microlib (i.e., *MICLIB* is present in the RHS) and to reprocess all the isotopes from the cross section libraries. In this case, (**desclib**) takes the simplified form:

Table 8: Structure (**desclib**)

```
[ EDIT iprint ]
{ INTR | SUBG | PT | PTMC | PTSL | RSE [ svdeps ] | NEWL } [ MACR ]
MIXS ;
```

Alternatively if *OLDLIB* is absent or represents a second MICROLIB, (**desclib**) takes the form:

Table 9: Structure (**desclib**)

```
[ EDIT iprint ]
MAXS [[ (descmix2) ]]
```

Finally, if *OLDLIB* represents BURNUP structure, (**desclib**) takes the form:

Table 10: Structure (**desclib**)

```
[ EDIT iprint ]
BURN { iburn | tburn } [[ (descmix2) ]]
```

with

**EDIT** keyword used to modify the print level *iprint*.

*iprint* index used to control the printing in this operator. It must be set to 0 if no printing on the output file is required while values >0 will increase in steps the amount of information transferred to the output file. If  $iprint \geq 10$ , the depletion chain is printed in the format of structure (**descdepl**). If  $iprint \geq 20$ , the depletion chain is also printed in the format of structure (**descdeplA2**).

**MXIS** keyword used to redefine the maximum number of isotopes per mixture.

*nmisot* the maximum number of isotopes per mixture. By default up to 300 different isotopes per mixture are permitted.

**NMIX** keyword used to define the number of material mixtures. This data is required if *MICLIB* is created.

*nmixt* the maximum number of mixtures (a mixture is characterized by a distinct set of macroscopic cross sections).

**CALENDF** keyword to set the accuracy of the CALENDF probability tables.

|               |   |
|---------------|---|
| <i>ipreci</i> | integer set to 1, 2, 3 or 4. The highest the value, the more accurate are the probability tables. The default value is <i>ipreci</i> =4.  |
| CTRA          | keyword to specify the type of transport correction that should be generated and stored on the MICROLIB. The transport correction is to be subtracted from the total and isotropic ( $P_0$ ) within-group scattering cross sections. A leakage correction, equal to the difference between current- and flux-weighted total cross sections ( $\sigma_1 - \sigma_0$ ) is also applied in the APOL, OLDW and LEAK cases. All the operators that will read this MICROLIB will then have access to transport corrected cross sections. The default is no transport correction.  |
| NONE          | keyword to specify that no transport correction should be used in this calculation.   |
| APOL          | keyword to specify that an APOLLO type transport correction based on the linearly anisotropic ( $P_1$ ) within-group scattering cross sections is to be set. This correction assumes that the micro-reversibility principle is valid for all energy groups. This type of correction uses $P_1$ scattering information present on the library.   |
| WIMS          | This type of correction uses directly a transport-correction provided on the library. Such information is available in WIMSD4, WIMSE and WIMS-AECL libraries. This is the new recommended option with WIMS-type libraries. <i>This option has no effect on libraries that does not contain transport correction information.</i>  |
| OLDW          | keyword to specify that a WIMS type transport correction based on the $P_1$ scattering cross sections is to be set. This correction assumes that the micro-reversibility principle is valid only for groups energies less than 4.0 eV. For the remaining groups a $1/E$ current spectrum is considered in the evaluation of the transport correction. This type of correction uses $P_1$ scattering information present on the library.   |
| LEAK          | A leakage correction is applied to the total and $P_0$ within-group scattering cross sections. No transport correction is applied in this case.   |
| ANIS          | keyword to specify the maximum level of anisotropy for the scattering cross sections.   |
| <i>naniso</i> | number of Legendre orders for the representation of the scattering cross sections. Isotropic scattering is represented by <i>naniso</i> =1 while <i>naniso</i> =2 represents linearly anisotropic scattering. Generally the linearly anisotropic ( $P_1$ ) scattering contributions are taken into account via the transport correction (see CTRA keyword) in the transport calculation. For $B_1$ or $P_1$ leakage calculations, the linearly anisotropic scattering cross sections are taken into account explicitly. The default value is <i>naniso</i> =2.  |
| STERN         | keyword to specify the application of the Sternheimer density correction for charged particles.   |
| <i>nstern</i> | index used to control the Sternheimer correction application. Sternheimer correction applied for both restricted total stopping power and heat deposition cross section (H-FACTOR) is represented by <i>nstern</i> = 1. A complete deactivation of the Sternheimer correction is obtained by setting <i>nstern</i> = 0. By default, the Sternheimer density correction is applied for both quantities. Notes: 1) The Sternheimer density correction should be applied for both quantities except for specific charged particles cross sections perturbations analysis; 2) The Sternheimer density correction should be applied on macroscopic cross sections. However, the heat deposition cross section contains a microscopic collisional stopping power which has not been corrected in ELECTR module of NJOY. This is why the charged particle H-FACTOR data – recovered from microscopic libraries produced by ELECTR, but not those produced by CEPXS-BFP – should be corrected in DRAGON5. |
| ADJ           | keyword to specify the production of adjoint macroscopic cross sections. By default, direct cross sections are produced.  |
| PROM          | keyword to specify that prompt neutrons are to be considered for the calculation of the fission spectrum. By default, the contribution due to delayed neutrons is considered. This option is only compatible with a MATXS or MATXS2 format library.   |

|               |   |
|---------------|---|
| SKIP          | keyword to recover the user-defined microlib data without processing any library (i.e., without temperature and/or dilution interpolation).   |
| INTR          | keyword to perform a temperature and dilution interpolation of the microscopic cross sections present in the libraries. The bin-type cross-section data is not processed. This is the default option.   |
| SUBG          | keyword to activate the calculation of the physical probability tables using the temperature-interpolated cross-section data as input. <sup>[12,14]</sup> The bin-type cross-section data is not processed.   |
| PT            | keyword to activate the calculation of the CALENDF-type mathematical probability tables ( <i>without</i> slowing-down correlated weight matrices) using the bin-type cross-section data as input. <sup>[13]</sup> This option is compatible with the Sanchez-Coste self-shielding method and with the subgroup projection method (SPM). <sup>[15]</sup>   |
| PTMC          | this option is similar to the PT procedure. Here, the base points of the probability tables corresponding to fission and scattering cross sections and to components of the transfer scattering matrix are also obtained using the CALENDF approach.  |
| PTSL          | keyword to activate the calculation of the CALENDF-type mathematical probability tables and slowing-down correlated weight matrices using the bin-type cross-section data as input. <sup>[14]</sup>   |
| RSE           | keyword to activate the generation of information for the resonance spectrum expansion (RSE) method. <sup>[16]</sup>  |
| <i>svdeps</i> | rank accuracy $\epsilon_{svd}$ of the singular value decomposition. Singular values $w_i \leq \epsilon_{svd} \Delta u_{elem}$ are set to zero. $\Delta u_{elem}$ is the elementary lethargy width of the Autolib. The default value is $svdeps=1.0 \times 10^{-3}$ .  |
| NEWL          | keyword to activate the calculation of a DRAGLIB library using the temperature-interpolated cross-section data as input. The bin-type cross-section data is processed.  |
| MACR          | keyword to force the calculation of the embedded macrolib. By default, the embedded macrolib is computed, <i>except if</i> one of the key words SKIP, INTR, SUBG, PT or NEWL is used.   |
| ADED          | keyword to specify the input of additional cross sections to be treated by DRAGON. These cross sections are not needed to solve the transport equation but are recognized by the EDI: and utility operators.  |
| <i>nedit</i>  | number of types of additional cross sections.   |
| <i>HEDIT</i>  | <p><b>character*6</b> name of an additional cross-section type. This name also corresponds to vectorial reactions in a MATXS and MATXS2 format library. For example:</p> <p>NWTO/NWT1=<math>P_0/P_1</math> library weight functions.<br/> NTOTO/NTOT1=<math>P_0/P_1</math> neutron total cross sections.<br/> NELAS=Neutron elastic scattering cross sections (MT=2).<br/> NINEL=Neutron inelastic scattering cross sections (MT=4).<br/> NG=Neutron radiative capture cross sections (MT=102).<br/> NFTOT=Total fission cross sections (MT=18).<br/> NUDEL=Number of delayed secondary neutrons (Nu-D / MT=455).<br/> NFSLO=<math>\nu</math>*slow fission cross section.<br/> NHEAT=Heat production cross section.<br/> CHIS/CHID=Slow/delayed fission spectrum.<br/> NF/NNF/N2NF/N3NF=<math>\nu</math>*partial fission cross sections (MT=19, 20, 21 and 38).<br/> N2N/N3N/N4N=(n,2n), (n,3n), (n,4n) cross sections (MT=16, 17 and 37).<br/> NP/NA=(n,p) and (n,<math>\alpha</math>) transmutation cross sections (MT=103 and 107).</p> <p>By default, DRAGON will always attempt to recover the additional cross sections NG, NFTOT, NHEAT and N2N which are required for the depletion calculations.</p> |

|          |   |
|----------|---|
| DEPL     | keyword to specify that the isotopic depletion (burnup) chain is to be read. For a given LIB: execution only one isotopic depletion chain can be read.  |
| MIXS     | keyword to specify that the mixture description is to be read. For a given LIB: execution more than one cross-section library can be read.  |
| LIB:     | keyword to specify the type of library from which the isotopic depletion chain or microscopic cross section is to be read. It is optional when preceded by the keyword DEPL in which case the isotopic depletion chain is read from the standard input file.  |
| DRAGON   | keyword to specify that the isotopic depletion chain or the microscopic cross sections are in the DRAGLIB format.   |
| MATXS    | keyword to specify that the microscopic cross sections are in the MATXS format of NJOY-II and NJOY-89 (no depletion data available for libraries using this format).  |
| MATXS2   | keyword to specify that the microscopic cross sections are in the MATXS format of NJOY-91 (no depletion data available for libraries using this format). The MATXS file is a binary sequential file by default. If the name <i>NAMEFIL</i> has a leading “_” character, the MATXS file is expected to be BCD-formatted, as produced by NJOY.  |
| WIMSD4   | keyword to specify that the isotopic depletion chain and the microscopic cross sections are in the WIMSD4 format, as produced by module <i>wimsr</i> of NJOY with flag <i>iverw</i> = 4. This format is supported by the WLUP project. <sup>[17]</sup>  |
| WIMSE    | keyword to specify that the isotopic depletion chain and the microscopic cross sections are in the WIMSE format, as produced by module <i>wimsr</i> of NJOY with flag <i>iverw</i> = 5.   |
| WIMSAECL | keyword to specify that the isotopic depletion chain and the microscopic cross sections are in the WIMS-AECL format.  |
| NDAS     | keyword to specify that the isotopic depletion chain and the microscopic cross sections are in the NDAS format, as used in recent versions of WIMS-AECL.  |
| APLIB1   | keyword to specify that the microscopic cross sections are in the APOLLO-1 format. There are no depletion chains available for libraries using this format.   |
| APLIB2   | keyword to specify that the microscopic cross sections are in the APOLLO-2 direct access format. There are no depletion chains available for libraries using this format. However, fission yields, radioactive decay constants and energy released per fission or radiative capture are recovered from the file. Only versions of the APOLIB-2 libraries subsequent or equal to CEA93-V4 can be processed. The list of isotopes (standard and self-shielded) available in an APOLIB-2 is printed by setting the print flag to a value <i>iprint</i> ≥ 10. |
| APXSM    | keyword to specify that the microscopic cross sections are in the APOLIB-XSM format, the output format of N2A2 utility. There are no depletion chains available for libraries using this format. However, fission yields, radioactive decay constants and energy released per fission or radiative capture are recovered from the file. The list of isotopes (standard and self-shielded) available in an APOLIB-XSM is printed by setting the print flag to a value <i>iprint</i> ≥ 10.  |
| APLIB3   | keyword to specify that the microscopic cross sections are in the APOLIB-3 format, the output format of the Galilee system. An ENDF/B evaluation is represented by three HDF5 files:<br><b>NAME1:</b> HDF5 file containing infinite dilution information<br><b>NAME2:</b> HDF5 file containing resonance self-shielding information<br><b>NAME3:</b> HDF5 file containing depletion chains, branching ratio, fission yields and energy deposition information.  |



After DEPL, the FIL: keyword is followed by the concatenation of NAME1 and NAME3 with a colon character (:) between the two names. After MIXS, the FIL: keyword is followed by the concatenation of NAME1 and NAME2 with a colon character (:) between the two names. The list of isotopes (standard and self-shielded) available in an APOLIB-3 is printed by setting the print flag to a value  $i_{print} \geq 10$ .

**MICROLIB** keyword to specify that the microscopic cross sections are in a MICROLIB-formatted object, as produced by DRAGON. This format is similar to the DRAGLIB format where the isotopes are stored in elements of list ISOTOPESLIST instead of been stored as independent sub-directories.

**FIL:** keyword to specify the name of the file where is stored the isotopic depletion data.

**NAMEFIL** **character\*64** name of the library where the isotopic depletion chain or the microscopic cross sections are stored.

Library names in DRAGLIB format are limited to 12 characters.

An APLIB3 library name is the concatenation of two names with a colon character (:) between them:

```
DEPL LIB: APLIB3 FIL: CLA99CEA93:CLA99CEA93_EVO
MIXS LIB: APLIB3 FIL: CLA99CEA93:CLA99CEA93_SS
```

A NDAS library is made of two or more files. These file names must be concatenated in a single NAMEFIL name, using colons as separators. The ASCII index file is always the first, followed by optional patch files, and terminated by the main direct-access binary file. The following sample data line corresponds to a NDAS library without patch:

```
MIXS LIB: NDAS FIL: E65LIB6.idx:E65LIB6.sdb
```

*ndepl* number of isotopes in the depleting chain.

**(descdepl)** input structure describing the depletion chain (see Section 3.2.2).

**(descdeplA2)** simplified input structure describing the depletion chain in cases where an APOLIB-2 or APOLIB-XSM file is used (see Section 3.2.2).

**MAXS** keyword to specify that the mixture density on MICLIB are to be modified. If OLDLIB is present and **(descmix2)** is absent, a direct one to one correspondence between the isotope on both libraries is assumed. If OLDLIB and **(descmix2)** are present, only the mixture on the library file specified by **(descmix2)** are updated using information from the OLDLIB. If OLDLIB is absent and **(descmix2)** is present, only the mixture on MICLIB specified by **(descmix2)** are updated.

**BURN** keyword to specify that the mixture density on MICLIB are to be updated using information taken from OLDLIB. If **(descmix2)** is absent, a direct one to one correspondence between the isotope on OLDLIB and MICLIB is assumed. If **(descmix2)** is present, only the mixture specified by **(descmix2)** are updated using information from OLDLIB.

*iburn* burnup step from the burnup file to use. This step must be already present on the burnup file.

*tburn* burnup time in days from the burnup file to use. This time step must be already present on the burnup file.

**(descmix1)** input structure describing the isotopic and physical properties of a given mixture (see Section 3.2.3).

**(descmix2)** input structure describing perturbations to the isotopic and physical properties of a given mixture (see Section 3.2.3).

Note that it is possible to recompute the embedded macrolib in an existing microlib named MICRO by writing

```
MICRO := LIB: MICRO :: MACR MIXS ;
```

## 3.2.2 Depletion data structure

The structure (**descdepl**) describes the heredity of the radioactive decay and the neutron activation chain to be used in the isotopic depletion calculation.

Table 11: Structure (**descdepl**)

```
CHAIN
[[ NAMDPL [ izae ]
  [[ { DECAy dcr |
      reaction [ energy ] } ] ]
  [ { STABLE |
      FROM [[ { DECAy | reaction } [[ yield NAMPAR ] ] ] } ] ] ] ] ]
ENDCHAIN
```

with:

|                 |   |
|-----------------|---|
| CHAIN           | keyword to specify the beginning of the depletion chain.  |
| NAMDPL          | <b>character*12</b> name of an isotope (or isomer) of the depletion chain that appears in the cross-section library.  |
| <i>izae</i>     | optional six digit integer representing the isotope. The first two digits represent the atomic number of the isotope; the next three indicate its mass number and the last digit indicates the excitation level of the nucleus (0 for a nucleus in its ground state, 1 for an isomer in its first excited state, etc.). For example, $^{238}\text{U}$ in its ground state will be represented by <i>izae</i> =922380. |
| DECAy           | indicates that a decay reaction takes place either for production of this isotope or its depletion.   |
| <i>dcr</i>      | radioactive decay constant (in $10^{-8} \text{ s}^{-1}$ ) of the isotope. By default, <i>dcr</i> =0.0.  |
| <i>reaction</i> | <b>character*6</b> identification of a neutron-induced reaction that takes place either for production of this isotope, its depletion, or for producing energy. Example of reactions are following:   |
| NG              | indicates that a radiative capture reaction takes place either for production of this isotope, its depletion or for producing energy.   |
| N2N             | indicates that the following reaction is taking place: $n + {}^A X_Z \rightarrow 2n + {}^{A-1} X_Z$   |
| N3N             | indicates that the following reaction is taking place: $n + {}^A X_Z \rightarrow 3n + {}^{A-2} X_Z$   |
| N4N             | indicates that the following reaction is taking place: $n + {}^A X_Z \rightarrow 4n + {}^{A-3} X_Z$   |
| NP              | indicates that the following reaction is taking place: $n + {}^A X_Z \rightarrow p + {}^A Y_{Z-1}$  |

|               |  |
|---------------|--|
| NA            | indicates that the following reaction is taking place:   |
|               | $n + {}^A X_Z \rightarrow {}^4 \text{He}_2 + {}^{A-3} X_{Z-2}$   |
| NFTOT         | indicates that a fission is taking place.  |
| <i>energy</i> | energy (in MeV) recoverable per neutron-induced reaction of type <i>reaction</i> . If the energy associated to radiative capture is not explicitly given, it should be added to the energy released per fission. By default, <i>energy</i> =0.0 MeV. |
| STABLE        | non depleting isotope. Such an isotope may produces energy by neutron-induced reactions (such as radiative capture).   |
| FROM          | indicates that this isotope is produced from decay or neutron-induced reactions.   |
| <i>yield</i>  | branching ratio or production yield expressed in fraction.   |
| NAMPAR        | <b>character*12</b> name of the a parent isotope (or isomer) that appears in the cross-section library.  |
| ENDCHAIN      | keyword to specify the end of the depletion chain.   |

If the keyword APLIB2 or APXSM was used in structure (**desclib**), part of the depletion data is recovered from the APOLIB file: the fission yields, the radioactive decay constants and the energy released per fission or radiative capture. Moreover, the following simplified structure is used to provide the remaining depletion data:

Table 12: Structure (**descdeplA2**)

```
CHAIN
[[ NAMDPL [ FROM [[ { DECAY | reaction } yield NAMPAR ] ] ] ] ] ]
ENDCHAIN
```

In this case, the following rules apply:

- We should provide the names *NAMDPL* of *all* the depleting isotopes (i.e. isotopes with a time-dependent number density), including the pseudo fission products (PFP).
- The fission father reactions (**NFTOT**) are not given.
- The stable isotopes are automatically recovered from the APOLIB file. They are not given in structure (**descdeplA2**).
- An isotope is considered to be stable if it is not present in structure (**descdeplA2**), has no father and no daughter, but can release energy by fission or radiative capture.
- It is possible to truncate the isotope name *NAMDPL* at the underscore. For example, D20\_3\_P5 can be simply written D20.
- Only the radioactive decay constants of the isotopes present in structure (**descdeplA2**) are recovered from the APOLIB file. The radioactive decay constants of the other isotopes are set to zero.

## 3.2.3 Mixture description structure

The structure (**descmix1**) is used to describe the isotopic composition and the physical properties, such as the temperature and density, of a mixture.

Table 13: Structure (**descmix1**)

```

MIX [ matnum ] {
  [ temp [ denmix ] ] [ { NOEV | EVOL } ] [ { NOGAS | GAS } ]
  [[ [ NAMALI = ] NAMISO dens [ { dil | INF } ] ]
  [ [ CORR ] inrs ] [ DBYE tempd ] [ SHIB NAMS ]
  [ THER ntfg HINC [ TCOH HCOH ] [ RESK ] ]
  [ IRSET { gir | { PT | PTMC | PTSL } } { nir | NONE } ] [ { NOEV | EVOL | SAT } ] ] ] ]
  |
  COMB [[ mati relvol ] ] | COPY numold }

```

where:

|               |   |
|---------------|---|
| <b>MIX</b>    | keyword to specify the number identifying the next mixture to be read.  |
| <i>matnum</i> | mixture identifier. The maximum value that <i>matnum</i> may have is <i>nmixt</i> . When <i>matnum</i> is absent, the mixtures are numbered successively starting from 1 if no mixture has yet been specified or from the last mixture number specified + 1.  |
| <i>temp</i>   | absolute temperature (in Kelvin) of the isotopic mixture. It is optional only when this mixture is to be updated, in which case the old temperature associated with the mixture is used.  |
| <i>denmix</i> | mixture density in $g\ cm^{-3}$ .   |
| <i>NAMALI</i> | <b>character*8</b> alias name for an isotope to be used locally. When the alias name is absent, the isotope name used locally is identical to the first 8-character isotope name on the library.  |
| =             | keyword to specify to which isotope in a library is associated the previous alias name.   |
| <i>NAMISO</i> | <b>character*12</b> name of an isotope present in the library which is included in this mixture.  |
| <i>dens</i>   | isotopic concentration of the isotope <i>NAMISO</i> in the current mixture in $10^{24}cm^{-3}$ . When the mixture density <i>denmix</i> is specified, the relative weight percentage of each of the isotopes in this mixture is to be provided.   |
| <i>dil</i>    | group independent microscopic dilution cross section (in barns) of the isotope <i>NAMISO</i> in this mixture. It is possible to recalculate a group dependent dilution for an isotope by the use of the <b>SHI:</b> or <b>TONE:</b> operator (see Section 4.1 and Section 4.2). In this case, the dilution is only used as a starting point for the self-shielding iterations and has no effect on the final result. If the dilution is not given or is larger than $10^{10}$ barns, an infinite dilution is assumed.   |
| <b>INF</b>    | keyword to specify that a dilution of $10^{10}$ barns is to be associated with this isotope. This value represents an infinite dilution (the isotope is present in trace amounts only). It is possible to recalculate a group dependent dilution for an isotope by the use of the <b>SHI:</b> operator (see Section 4.1) or <b>TONE:</b> operator (see Section 4.2). In this case, the dilution is only used as a starting point for the self-shielding iterations and has no effect on the final result. If the dilution is not given an infinite dilution is assumed. |

|              |   |
|--------------|---|
| CORR         | keyword to specify that the resonances of an isotope are correlated with those of other isotopes with the same <i>inrs</i> index. This option is only available with the <i>Ribon extended</i> model <sup>[14]</sup> or with the <i>subgroup projection method</i> (SPM) <sup>[15]</sup> in energy groups where this model is set. If this option is selected for an isotope, it must be set for all isotopes with the same <i>inrs</i> index. By default, the resonances of distinct isotopes are assumed to be uncorrelated.  |
| <i>inrs</i>  | index of the resonant region associated with this isotope. By default <i>inrs</i> =0 and the isotope is not a candidate for self-shielding. When <i>inrs</i> ≠0, the isotope can be self-shielded where it is assumed that a given isotope distributed with different concentrations in a number of mixtures and having the same value of <i>inrs</i> will share the same fine flux. Should we wish to self-shield both the clad and the fuel it is important to assign a different <i>inrs</i> number to each. If a single type of fuel is located in different mixture in <i>onion-peel fashion</i> , it is necessary to attribute a single <i>inrs</i> value to this fuel. |
| DBYE         | keyword to specify that the absolute temperature of the isotope is different from that of the isotopic mixture. This option is useful to define Debye-corrected temperature.  |
| <i>tempd</i> | absolute temperature (in Kelvin) of the isotope. By default <i>tempd</i> = <i>temp</i> .  |
| SHIB         | keyword to specify that the name of the isotope containing the information related to the self-shielding is different from the initial name of the isotope. This option is not required if a MATXS or a DRAGLIB file is used.   |
| NAMS         | <b>character*12</b> name of a record in the library containing the self-shielding data. This name is required if the dilution is not infinite or a non zero resonant region is associated with this isotope and <i>NAMS</i> is different from <i>NAMISO</i> . This record must be contained in the same library file as record <i>NAMISO</i> .  |
| THER         | keyword to specify that the thermalization and resonant elastic scattering kernel effects are to be included with the cross sections when using a MATXS or MATXS2 format library.   |
| HINC         | <b>character*6</b> name of the incoherent thermalization effects which will be taken into account. The incoherent effects are those that may be described by the $S(\alpha, \beta)$ scattering law. The value FREE is used to simulate the effects of a gas.  |
| TCOH         | keyword to specify that coherent thermalization effects will be taken into account.   |
| HCOH         | <b>character*6</b> name of the coherent thermalization effects which will be taken into account. The coherent effects are the <i>vectorial reactions</i> in the MATXS or MATXS2 format library where the name is terminated by the '\$' suffix. They are generally available for graphite, beryllium, beryllium oxide, polyethylene and zirconium hydroxide.  |
| RESK         | keyword to specify that resonant elastic scattering kernel effects will be taken into account.  |
| <i>ntfg</i>  | number of energy groups that will be affected by the thermalization and resonant elastic scattering kernel effects.   |
| IRSET        | keyword to specify an intermediate resonance (IR) approximation or the <i>Ribon extended</i> model for some energy groups. By default, an IR approximation with the value of the Goldstein-Cohen parameter found on the library is used. If no value is found on the library, a statistical (ST) model <sup>[18]</sup> is set in all groups by default. The "IRSET PT 1" option is set by default if keyword PT, PTMC or PTSL is selected in structure ( <b>desclib</b> ).  |
| <i>gir</i>   | imposed Goldstein-Cohen IR parameter. A Goldstein-Cohen IR parameter $0 \leq \lambda_g \leq 1$ is set in energy group <i>g</i> . A value of 1.0 stands for a statistical (ST) approximation. A value of 0.0 stands for an infinite mass (IM or WR) approximation.   |
| PT           | keyword to enable the calculation of CALENDF-type probability tables in some energy groups. The slowing-down correlated weight matrices are <i>not</i> computed. This type of probability tables is consistent with the Sanchez-Coste self-shielding method and with the subgroup projection method (SPM). <sup>[15]</sup>  |

|               |   |
|---------------|---|
| PTMC          | keyword to enable the calculation of CALENDF-type probability tables, similar to the PT procedure. Here, the base points of the probability tables corresponding to fission and scattering cross sections and to components of the transfer scattering matrix are also obtained using the CALENDF approach.   |
| PTSL          | keyword to enable the calculation of CALENDF-type probability tables, consistent with the Ribon extended model, in some energy groups.  |
| <i>nir</i>    | the intermediate resonance (IR) approximation or the Ribon extended model is imposed for energy groups with an index equal or greater than <i>nir</i> . A statistical (ST) model is set in other groups.  |
| NONE          | keyword to specify that a statistical (ST) model is set in all groups.  |
| NOEV          | keyword to force a mixture or a nuclide to be non-depleting (even in cases where it is potentially depleting). Note that the mixture or nuclide keeps its capability to produce energy. By default, the depleting isotopes are automatically recognized as depleting.   |
| EVOL          | keyword to force a mixture or a nuclide to be depleting. By default, only fission products and fissile isotopes are depleting.  |
| NOGAS         | keyword to specify that a mixture has a solid or liquid state (used for stopping power correction). This is the default option.   |
| GAS           | keyword to specify that a mixture has a gaseous state (used for stopping power correction).   |
| SAT           | keyword to force a nuclide to be at saturation. By default, the saturation approximation is automatically set as a function of the half life and capture cross sections of the isotope.   |
| COMB          | keyword to specify that this mixture is reset with a combination of previously defined mixtures.  |
| <i>mati</i>   | number associated with a previously defined mixture. In order to insert some void in a mixture use <i>mati</i> =0. If the mixture is not already defined one assumes that it represents a voided mixture.   |
| <i>relvol</i> | relative volume $V_i$ occupied by mixture <i>mati</i> = <i>i</i> in <i>matnum</i> . Two cases can be considered, namely that where the density $\rho_i$ of each mixture <i>mati</i> is provided along with the weight percent for each isotope <i>J</i> ( $W_{i,J}^j$ ) and the case where the explicit concentration $N_i^j$ of each isotope in a <i>mati</i> was provided (it is forbidden to combined two mixtures with different isotopic content description). In the case where the initial mixtures are defined using densities $\rho_i$ , the density ( $\rho_k$ ) and volume ( $V_k$ ) of the final mixture will become: |

$$V_k = \sum_i V_i$$

$$\rho_k = \frac{1}{V_k} \sum_i \rho_i V_i$$

and the weight percent will be changed in a consistent way, namely

$$W_{k,J} = \frac{\rho_i V_i W_{i,J}}{\rho_k V_k}$$

When the explicit concentration are given we will use:

$$N_{k,J} = \frac{V_i N_{i,J}}{V_k}$$

There is a very common usage of keyword COMB. In the following example, a new mixture with index 42 is defined in such a way to be identical to an existing mixture with index 25.

MIX 42 COMB 25 1.0

**COPY** keyword to specify that mixture *matnum* in *MICLIB* is a copy of mixture *numold* in a MICROLIB-formatted object (type MICROLIB) named *NAMEFIL*, previously produced by DRAGON. This option is useful to permute mixture indices before the flux calculation.

*numold* mixture index existing in MICROLIB object named *NAMEFIL*.

Note that in the structure (**descmix1**) one only needs to describe the isotopes initially present in each mixture. DRAGON will then automatically associate with each depleting mixture the additional isotopes required by the available burnup chain. Moreover, the microscopic cross-section library associated with these new isotopes will be the same as that of their parent isotope. For example, suppose that mixture 1 contains isotope U235 which is to be read on the DRAGON-formatted library associated with file DRAGLIB. Assume also that the depletion chain, which is written on the WIMS-AECL format library associated with file WIMSLIB, states that isotope U236 (initially absent in the mixture) can be generated from U235 by neutron capture. Then, one can either specify explicitly from which library file the microscopic cross sections associated with isotope U236 (zero concentration) are to be read, or omit U236 from the mixture description in which case DRAGON will assume that the microscopic cross sections associated with isotope U236 are to be read from the same library as the cross section for isotope U235. Note that the isotopes added automatically will remain at infinite dilution.

If the SHI: or TONE: module is used for performing self-shielding calculation, the self-shielding data for an isotope takes the form

```
U235      = U235  5.105E-5 1
```

where the last index indicates the self-shielding region (1 in this case).

If the USS: module implementing the subgroup method is used, additional self-shielding data is required:

- Physical probability tables are used (keyword SUBG). Consider the following data:

```
U235      = U235  5.105E-5 1 IRSET 0.0 81
```

The data “IRSET 0.0 81” indicates that a Goldstein-Cohen parameter  $\lambda_g$  equal to 0.0 is used for all energy groups with an index equal or greater than 81. A value of  $\lambda_g = 1.0$  corresponding to a statistical model is used by default.

- Mathematical probability tables (with slowing-down correlated weight matrices) are used (keyword PTSL) or mathematical probability tables with the subgroup projection method (SPM)<sup>[15]</sup> are used (keyword PT or PTMC). Consider the following data:

```
U235      = U235  5.105E-5 1 IRSET PT 5
```

The Goldstein-Cohen approximation is not used with mathematical (CALENDF) probability tables. The data “IRSET PT 5” indicates that the CALENDF probability tables are used for energy groups with an index equal or greater than 5, *with the exception of the energy groups where no Autolib data is available* and a statistical model (with physical probability tables) is used for energy groups with an index smaller than 5. A statistical model is also imposed in groups where no Autolib data is available.

The following data:

```
U235      = U235  5.105E-5 1 IRSET PT NONE
```

is useful to impose the statistical model (with physical probability tables) in all energy groups. This is equivalent of selecting the SUBG keyword in structure (**desclib**).

Mathematical (CALENDF) probability tables are used in each energy group where Autolib data is available if the following data is set:



U235 = U235 5.105E-5 1 IRSET PT 1

This latter definition is equivalent to the default behavior obtained using

U235 = U235 5.105E-5 1

The structure (**descmix2**) is used to describe the modifications in the isotopic composition of a mixture.

Table 14: Structure (**descmix2**)

MIX *matnum* [ *matold* ] [ *relden* ] [ *NAMALI dens* ] [ { NOEV | EVOL } ]

where:

|               |  |
|---------------|--|
| MIX           | keyword to specify the number identifying the next mixture to be updated.  |
| <i>matnum</i> | mixture identifier on <i>MICLIB</i> .  |
| <i>matold</i> | mixture identifier on <i>OLDLIB</i> .  |
| <i>relden</i> | relative density of updated mixture. The concentration of each isotope in the mixture is to be multiplied by this factor whether it comes from <i>MICLIB</i> , from <i>OLDLIB</i> or is specified explicitly using <i>dens</i> . |
| <i>NAMALI</i> | <b>character*8</b> alias name for an isotope on <i>MICLIB</i> to be modified.  |
| <i>dens</i>   | isotopic concentration of the isotope <i>NAMISO</i> in the current mixture in $10^{24}cm^{-3}$ . When <i>relden</i> is specified, the isotopic concentration becomes <i>dens</i> × <i>relden</i> .                               |
| NOEV          | keyword to force a mixture to be non-depleting (even in cases where it is potentially depleting). Note that the mixture keeps its capability to produce energy.  |
| EVOL          | keyword to force a mixture to be depleting. By default, only mixtures containing fission products and/or fissile isotopes are depleting.   |

### 3.2.4 Cross sections in Dragon

Multigroup cross sections in Draglibs files are of two types:

- Vectorial cross sections  $\sigma_{x,g}$
  - Matrix cross sections  $\sigma_{x,g\leftarrow h}$ .
1. Total cross sections  $\sigma_g$  are provided in ENDF evaluations as  $MT = 1$ . They are redundant with other information in the same evaluation. The vectorial total cross section is defined as

$$\begin{aligned} \sigma_g &= \sigma_{e,g} + \sigma_{in,g} + \sigma_{(n,2n),g} + \sigma_{(n,3n),g} + \sigma_{(n,4n),g} + \sigma_{f,g} + \sigma_{p,g} + \sigma_{\gamma,g} + \sigma_{d,g} + \sigma_{t,g} + \sigma_{\alpha,g} \\ &+ \sigma_{2\alpha,g} + \sigma_{(n,np),g} + \sigma_{any,g} \end{aligned} \quad (3.1)$$

where  $\sigma_{e,g}$  and  $\sigma_{in,g}$  are the elastic and inelastic scattering cross sections and where the matrix cross sections are transformed into vectorial cross sections using

$$\sigma_{x,g} = \sum_h \sigma_{x,h\leftarrow g}, \quad \text{except for } (n,xn) \text{ reactions.} \quad (3.2)$$

2. Inelastic scattering cross sections are sum over MT 51 to 91 in the ENDF evaluation:

$$\sigma_{\text{in},g} = \sum_{mt=51}^{91} \sigma_{mt,g} = \sum_{mt=51}^{91} \sum_h \sigma_{mt,h \leftarrow g}. \quad (3.3)$$

3. (n,xn) vectorial cross sections are divided by the secondary neutron multiplicity:

$$\sigma_{(n,2n),g} = \frac{1}{2} \sum_h \sigma_{(n,2n),h \leftarrow g}, \quad \sigma_{(n,3n),g} = \frac{1}{3} \sum_h \sigma_{(n,3n),h \leftarrow g}, \quad \sigma_{(n,4n),g} = \frac{1}{4} \sum_h \sigma_{(n,4n),h \leftarrow g}. \quad (3.4)$$

4. SCAT matrix reactions in Dragon are defined as

$$\begin{aligned} \sigma_{\text{scat},h \leftarrow g} &= \sigma_{e,h \leftarrow g} + \sigma_{(n,2n),h \leftarrow g} + \sigma_{(n,3n),h \leftarrow g} + \sigma_{(n,4n),h \leftarrow g} + \sum_{mt=51}^{91} \sigma_{mt,h \leftarrow g} \\ &+ \sigma_{\text{any},h \leftarrow g}. \end{aligned} \quad (3.5)$$

5. Vectorial *neutronic scattering* (SIGS) in Dragon is defined as

$$\sigma_{\text{sig},g} = \sum_h \sigma_{\text{scat},h \leftarrow g} \quad (3.6)$$

so that the *neutronic absorption*, used to compute the  $K_\infty$  is

$$\begin{aligned} \sigma_g - \sigma_{\text{sig},g} &= \sigma_{f,g} + \sigma_{p,g} + \sigma_{\gamma,g} + \sigma_{d,g} + \sigma_{t,g} + \sigma_{\alpha,g} + \sigma_{2\alpha,g} + \sigma_{(n,np),g} \\ &- \sigma_{(n,2n),g} - 2\sigma_{(n,3n),g} - 3\sigma_{(n,4n),g} \end{aligned} \quad (3.7)$$

where all these terms are available in the Dragon microlib under the following names:

| Dragon name | $\sigma_x$              | type                 |
|-------------|-------------------------|----------------------|
| NTOTO       | $\sigma_g$              | total                |
| SIGS00      | $\sigma_{\text{sig},g}$ | neutronic scattering |
| NFTOT       | $\sigma_{f,g}$          | fission              |
| NP          | $\sigma_{p,g}$          | (n,p)                |
| NG          | $\sigma_{\gamma,g}$     | (n, $\gamma$ )       |
| ND          | $\sigma_{d,g}$          | (n,d)                |
| NT          | $\sigma_{t,g}$          | (n,t)                |
| NA          | $\sigma_{\alpha,g}$     | (n, $\alpha$ )       |
| N2A         | $\sigma_{2\alpha,g}$    | (n,2 $\alpha$ )      |
| NNP         | $\sigma_{(n,np),g}$     | (n,np)               |
| NX          | $\sigma_{\text{any},g}$ | (n,anything)         |
| N2N         | $\sigma_{(n,2n),g}$     | (n,2n)               |
| N3N         | $\sigma_{(n,3n),g}$     | (n,3n)               |
| N4N         | $\sigma_{(n,4n),g}$     | (n,4n)               |

6. The *infinite multiplication factor*  $K_\infty$  in a Dragon mixture is defined as

$$K_\infty = \frac{\sum_g \nu \Sigma_{f,g} \bar{\phi}_g}{\sum_g (\Sigma_g - \Sigma_{\text{sig},g}) \bar{\phi}_g} \quad (3.8)$$

where  $\nu \Sigma_{f,g}$ ,  $\Sigma_g$  and  $\Sigma_{\text{sig},g}$  are the macroscopic  $\nu$ -fission, total and neutronic scattering cross sections, and  $\bar{\phi}_g$  is the neutron flux.

### 3.3 The GEO: module

The **GEO:** module is used to create or modify a geometry. The geometry definition module in DRAGON permits all the characteristics (coordinates, region mixture and boundary conditions) of a simple or complex geometry to be specified. The method used to specify the geometry is independent of the discretization module to be used subsequently. Each geometry is stored in the form of a GEOMETRY data structure under its given name. It is always possible to modify an existing geometry or copy it under a new name. The calling specifications are:

Table 15: Structure (**GEO:**)

```
{
  GEONAM := GEO: { GEONAM | OLDGEO } :: (descgcnt)
|
  GEONAM := GEO: :: (descgtyp) (descgcnt)
}
```

where

|                     |   |
|---------------------|---|
| <i>GEONAM</i>       | <b>character*12</b> name of the GEOMETRY created or modified.   |
| <i>OLDGEO</i>       | <b>character*12</b> name of a read-only GEOMETRY. The type and all the characteristics of <i>OLDGEO</i> will be copied onto <i>GEONAM</i> before this later geometry is modified. |
| ( <b>descgtyp</b> ) | structure describing the geometry type of <i>GEONAM</i> (see Section 3.3.1).  |
| ( <b>descgcnt</b> ) | structure describing the characteristics of a geometry (see Section 3.3.1).   |

#### 3.3.1 Data input for module **GEO:**

Structures (**descgtyp**) and (**descgcnt**) are used to define respectively the type of geometry that will be define and the contents of this geometry (dimensions, materials, boundary conditions). The module **GEO:** can be recursively called from (**descgcnt**) as an embedded module, in order to define sub-geometries:

Table 16: Structure (**descgtyp**)

```
{ VIRTUAL |
HOMOGE |
SPHERE lr |
CAR1D lx |
CAR2D lx ly |
CAR3D lx ly lz |
TUBE lr [ lx ly ] |
TUBEX lr { lx | lx ly lz } |
TUBEY lr { ly | lx ly lz } |
TUBEZ lr { lz | lx ly lz } |
RTHETA lr lz |
```

continued on next page

Structure (**descgtyp**)

continued from last page

```

HEX lh |
HEXZ lh lz |
HEXT nh |
HEXTZ nh lz |
CARCEL lr [ lx ly ] |
CARCELX lr { lx | lx ly lz } |
CARCELY lr { ly | lx ly lz } |
CARCELZ lr { lz | lx ly lz } |
HEXCEL lr |
HEXCELZ lr lz |
HEXTCEL lr nh |
HEXTCELZ lr nh lz |
GROUP lp }

```

Table 17: Structure (**descgcnt**)

```

[ EDIT iprint ]
(descBC)
(descSP)
(descPP)
(descDH)
(descSIJ)
[[ :: SUBGEO := GEO: { (descgtyp) | SUBGEO | OLDGEO } (descgcnt)]]
;

```

where

|         |   |
|---------|---|
| VIRTUAL | keyword to specify that a virtual geometry description follows. This type of geometry is used to complete an assembly that has irregular boundaries.            |
| HOMOGE  | keyword to specify that a infinite homogeneous geometry description follows.  |
| SPHERE  | keyword to specify that a spherical geometry (concentric spheres) description follows.  |
| CAR1D   | keyword to specify that a one dimensional plane geometry (infinite slab) description follows.   |
| CAR2D   | keyword to specify that a two-dimensional Cartesian geometry description follows.   |
| CAR3D   | keyword to specify that a three-dimensional Cartesian geometry description follows.   |
| TUBE    | keyword to specify that a cylindrical geometry (infinite tubes or cylinders) description follows. This geometry can contain an imbedded $X - Y$ Cartesian mesh. |
| TUBEX   | keyword to specify that a polar $R - X$ cylindrical geometry description follows. This geometry can contain an imbedded $Y - Z$ Cartesian mesh.                 |
| TUBEY   | keyword to specify that a polar $R - Y$ cylindrical geometry description follows. This geometry can contain an imbedded $Z - X$ Cartesian mesh.                 |

|          |   |
|----------|---|
| TUBEZ    | keyword to specify that a polar $R - Z$ cylindrical geometry description follows. This geometry can contain an imbedded $X - Y$ Cartesian mesh.   |
| RTHETA   | keyword to specify that a polar geometry ( $R - \theta$ ) description follows.  |
| HEX      | keyword to specify that a two-dimensional hexagonal geometry description follows.   |
| HEXZ     | keyword to specify that a three-dimensional hexagonal geometry description follows.   |
| HEXT     | keyword to specify a single 2-D hexagonal cell geometry having a triangular mesh. This option is only supported by the <code>NXT</code> : tracking module (see Section 3.4).  |
| HEXTZ    | keyword to specify a single $Z$ directed 3-D hexagonal cell geometry having a triangular mesh (plane $X - Y$ ). This option is only supported by the <code>NXT</code> : tracking module (see Section 3.4).  |
| CARCEL   | keyword to specify that a two-dimensional mixed Cartesian cell (concentric tubes surrounded by a rectangle) description follows. The rectangle can now be subdivided into a fine mesh when the <code>EXCEL</code> : module is used.                     |
| CARCELX  | keyword to specify that a three-dimensional mixed Cartesian cell with tubes oriented along the $X$ -axis description follows. The three-dimensional Cartesian cell can now be subdivided into a fine mesh when the <code>EXCEL</code> : module is used. |
| CARCELY  | keyword to specify that a three-dimensional mixed Cartesian cell with tubes oriented along the $Y$ -axis description follows. The three-dimensional Cartesian cell can now be subdivided into a fine mesh when the <code>EXCEL</code> : module is used. |
| CARCELZ  | keyword to specify that a three-dimensional mixed Cartesian cell with tubes oriented along the $Z$ -axis description follows. The three-dimensional Cartesian cell can now be subdivided into a fine mesh when the <code>EXCEL</code> : module is used. |
| HEXCEL   | keyword to specify that a two-dimensional mixed hexagonal cell (concentric tubes surrounded by a hexagon) description follows.  |
| HEXCELZ  | keyword to specify that a three-dimensional mixed hexagonal cell with tubes oriented along the $Z$ -axis description follows.   |
| HEXTCEL  | keyword to specify a single 2-D hexagonal cell geometry having a triangular mesh and containing concentric annular regions.   |
| HEXTCELZ | keyword to specify a single $Z$ directed 3-D hexagonal cell geometry a triangular mesh and containing concentric $Z$ directed cylinders.  |
| GROUP    | keyword to specify that a <i>do-it-yourself</i> type geometry description follows.  |
| $l_x$    | number of subdivisions along the $X$ -axis (before mesh-splitting).   |
| $l_y$    | number of subdivisions along the $Y$ -axis (before mesh-splitting).   |
| $l_z$    | number of subdivisions along the $Z$ -axis (before mesh-splitting).   |
| $l_r$    | number of cylinders or spherical shells (before mesh-splitting).  |
| $l_h$    | number of hexagons in an axial plane (including the virtual hexagon).   |
| $nhr$    | number of concentric hexagons in a <code>HEXT</code> , <code>HEXTZ</code> , <code>HEXTCEL</code> or <code>HEXTCELZ</code> cell (see Figure 1). This will lead to an hexagon subdivided into $6N^2$ identical triangles.                                 |
| $l_p$    | number of types of cells (number of cells inside which a distinct flux will be calculated) for a <i>do-it-yourself</i> type geometry.   |
| EDIT     | keyword used to modify the print level <i>iprint</i> .  |

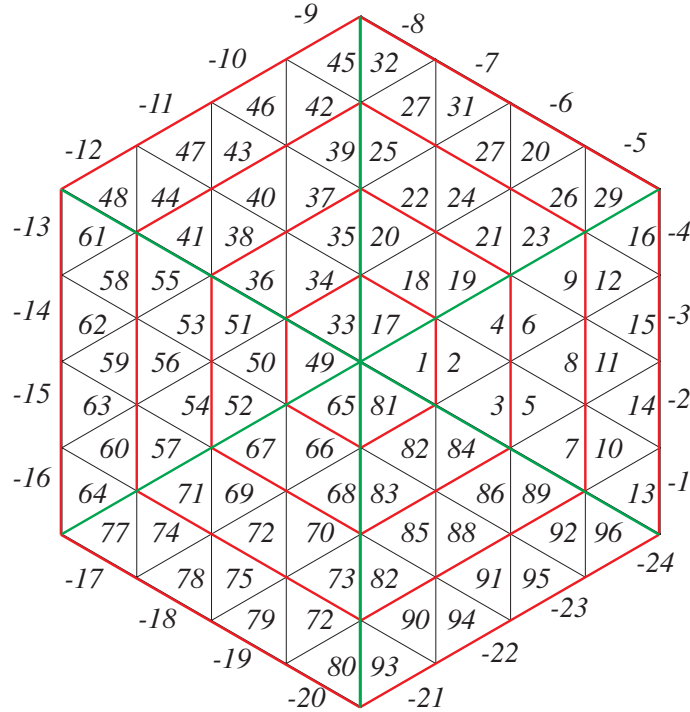

Figure 1: Hexagonal geometry with triangular mesh containing 4 concentric hexagon

|                    |  |
|--------------------|--|
| <i>iprint</i>      | index used to control the printing in this module. It must be set to 0 if no printing on the output file is required, to 1 for minimum printing (fixed default value) and to 2 for printing the geometry state vector. |
| ( <b>descBC</b> )  | structure allowing the boundary conditions surrounding the geometry to be treated (see Section 3.3.2).   |
| ( <b>descSP</b> )  | structure allowing the coordinates of a geometry to be described (see Section 3.3.3).  |
| ( <b>descPP</b> )  | structure allowing material mixtures to be associated with a geometry (see Section 3.3.4).   |
| ( <b>descDH</b> )  | structure used to specify double-heterogeneity data (see Section 3.3.5).   |
| ( <b>descSIJ</b> ) | structure used to specify the properties of <i>do-it-yourself</i> geometries (see Section 3.3.6).  |
| <i>SUBGEO</i>      | <b>character*12</b> name of the directory that will contain the sub-geometry.  |
| <i>OLDGEO</i>      | <b>character*12</b> name of a parallel directory containing an existing sub-geometry. The type and all the characteristics of <i>OLDGEO</i> will be copied onto <i>SUBGEO</i> .  |

Note that all the geometry described above are called *pure geometry* when they do not contain sub-geometry. When they do contain sub-geometry they will be called *composite geometry*.

### 3.3.2 Boundary conditions

The inputs corresponding to the (**descBC**) structure are the following:

Table 18: Structure (**descBC**)

```

[ X- { VOID | REFL | SSYM | DIAG | TRAN | SYME | ALBE { albedo | icode } | ZERO | PI/2 | PI
  | CYLI | ACYL { albedo | icode } } ]
[ X+ { VOID | REFL | SSYM | DIAG | TRAN | SYME | ALBE { albedo | icode } | ZERO | PI
  | CYLI | ACYL { albedo | icode } } ]
[ Y- { VOID | REFL | SSYM | DIAG | TRAN | SYME | ALBE { albedo | icode } | ZERO | PI/2 | PI
  | CYLI | ACYL { albedo | icode } } ]
[ Y+ { VOID | REFL | SSYM | DIAG | TRAN | SYME | ALBE { albedo | icode } | ZERO | PI
  | CYLI | ACYL { albedo | icode } } ]
[ Z- { VOID | REFL | SSYM | TRAN | SYME | ALBE { albedo | icode } | ZERO } ]
[ Z+ { VOID | REFL | SSYM | TRAN | SYME | ALBE { albedo | icode } | ZERO } ]
[ R+ { VOID | REFL | ALBE { albedo | icode } | ZERO } ]
[ HBC { S30 | SA60 | SB60 | S90 | R120 | R180 | SA180 | SB180 | COMPLETE }
{ VOID | REFL | SYME | ALBE { albedo | icode } | ZERO } ]
[ RADS [ ANG ] nrad ( xrad(ir), rrad(ir) [, ang(ir) ], ir=1,nrad ) ]

```

where:

- X-/X+ keyword to specify the boundary conditions associated with the negative or positive  $X$  surface of a Cartesian geometry.
- Y-/Y+ keyword to specify the boundary conditions associated with the negative or positive  $Y$  surface of a Cartesian geometry.
- Z-/Z+ keyword to specify the boundary conditions associated with the negative or positive  $Z$  surface of a Cartesian geometry.
- R+ keyword to specify the boundary conditions associated with the outer surface of a cylindrical or spherical geometry.
- HBC keyword to specify the boundary conditions associated with the outer surface of an hexagonal geometry.
- VOID keyword to specify that the surface under consideration has zero re-entrant angular flux. This side is an external surface of the domain.
- REFL keyword to specify that the surface under consideration has a reflective boundary condition. In most DRAGON calculations, this implies white boundary conditions. The main exception to this rule is when cyclic tracking in 2-D is considered and mirror like reflections are considered. A geometry is never unfolded to take into account a REFL boundary condition.
- SSYM keyword to specify that the surface under consideration has a specular (or mirror) reflective boundary condition. The main difference between REFL and SSYM is that for SSYM the cell may be unfolded to take into account the reflection at the boundary.
- DIAG keyword to specify that the Cartesian surface under consideration has the same properties as that associated with a diagonal through the geometry (see Figure 2). Note that two and only two DIAG surfaces must be specified. The diagonal symmetry is only permitted for square geometry and in the following combinations:

X+ DIAG Y- DIAG

or

X- DIAG Y+ DIAG

|               |  |
|---------------|--|
| TRAN          | keyword to specify that the surface under consideration is connected to the opposite surface of a Cartesian domain (see Figure 3). This option provides the facility to treat an infinite geometry with translation symmetry. The only combinations of translational symmetry permitted are: <ul style="list-style-type: none"> <li>• Translation along the <math>X</math>-axis<br/>X- TRAN X+ TRAN</li> <li>• Translation along the <math>Y</math>-axis<br/>Y- TRAN Y+ TRAN</li> <li>• Translation along the <math>Z</math>-axis<br/>Z- TRAN Z+ TRAN</li> </ul> |
| SYME          | keyword to specify that the Cartesian surface under consideration is virtual and that a reflection symmetry is associated with the adequately directed axis running through the center of the cells closest to this surface (see Figure 3). Only the hexagonal geometries S30 and SA60 can be surrounded by a SYME boundary condition if a specular condition is to be applied on this boundary.   |
| ALBE          | keyword to specify that the surface under consideration has an arbitrary albedo. This side is an external surface of the domain.   |
| <i>albedo</i> | geometric albedo corresponding to the boundary condition ALBE ( <i>albedo</i> >0.0).   |
| <i>icode</i>  | index of a physical albedo corresponding to the boundary condition ALBE. The numerical values of the physical albedo are supplied by the operator MAC: (see Section 3.1).  |
| ZERO          | keyword to specify that the surface under consideration has a zero-flux boundary condition. This side is an external surface of the domain.  |
| PI/2          | keyword to specify that the surface under consideration has a $\pi/2$ rotational symmetry (see Figure 3). The only $\pi/2$ symmetry permitted is related to sides (X- and Y-). This condition can be combined with a translation boundary condition:(PI/2 X- TRAN X+) and/or (PI/2 Y- TRAN Y+) (see Figure 4).   |
| PI            | keyword to specify that the surface under consideration has a $\pi$ rotational symmetry (see Figure 3). This keyword is useful for representing a Cartesian checkerboard pattern as shown in Fig. 5.   |
| CYLI          | the side under consideration has a zero incoming current boundary condition with a circular correction applied on the Cartesian boundary. This option is only available in the $X$ - $Y$ plane for CAR2D and CAR3D geometries defined for TRIVAC full-core calculations.   |
| ACYL          | the side under consideration has an arbitrary albedo with a circular correction applied on the Cartesian boundary. This option is only available in the $X$ - $Y$ plane for CAR2D and CAR3D geometries defined for TRIVAC full-core calculations.  |
| S30           | keyword to specify an hexagonal symmetry of one twelfth of an assembly (see Figure 6).   |
| SA60          | keyword to specify an hexagonal symmetry of one sixth of an assembly of type A (see Figure 6).   |
| SB60          | keyword to specify an hexagonal symmetry of one sixth of an assembly of type B (see Figure 7).   |
| S90           | keyword to specify an hexagonal symmetry of one quarter of an assembly (see Figure 7).   |
| R120          | keyword to specify a rotation symmetry of one third of an assembly (see Figure 8).   |



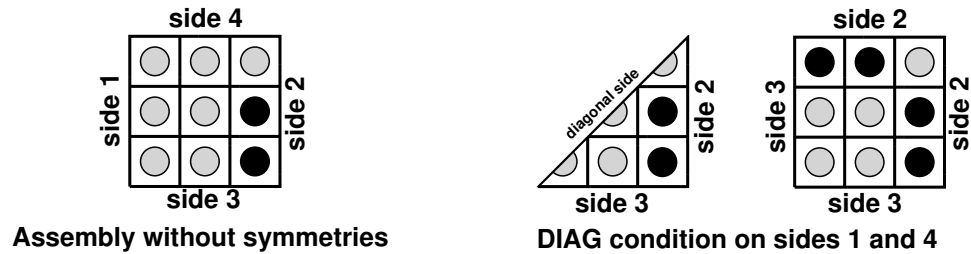

Figure 2: Diagonal boundary conditions in Cartesian geometry

- R180 keyword to specify a rotation symmetry of a half assembly (see Figure 8).
- SA180 keyword to specify an hexagonal symmetry of half a type A assembly (see Figure 9).
- SB180 keyword to specify an hexagonal symmetry of half a type B assembly (see Figure 10).
- COMPLETE keyword to specify a complete hexagonal assembly (see Figure 11).
- RADS This key word is used to specify the cylindrical correction applied in the  $X - Y$  plane for CAR2D and CAR3D geometries.<sup>[20]</sup>
- ANG This key word allows the angle (see Figure 12) of the cylindrical notch to be set. By default, no notch is present.
- nrad*s Number of different corrections along the cylinder main axis (i.e. the  $Z$  axis).
- xrad*(ir) Coordinate of the  $Z$  axis from which the correction is applied.
- rrad*(ir) Radius of the real cylindrical boundary.
- ang*(ir) Angle of the cylindrical notch. This data is given if and only if the key word **ANG** is present.  $ang(ir) = \frac{\pi}{2}$  by default (i.e. the correction is applied at every angle).

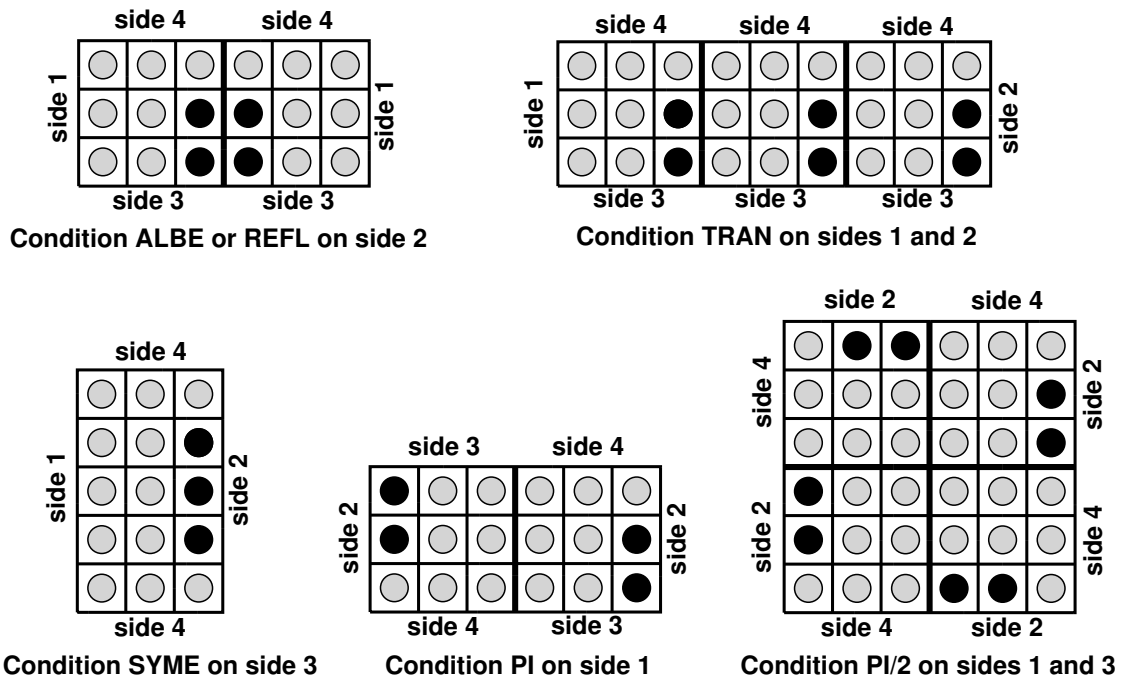

Figure 3: Various boundary conditions in Cartesian geometry

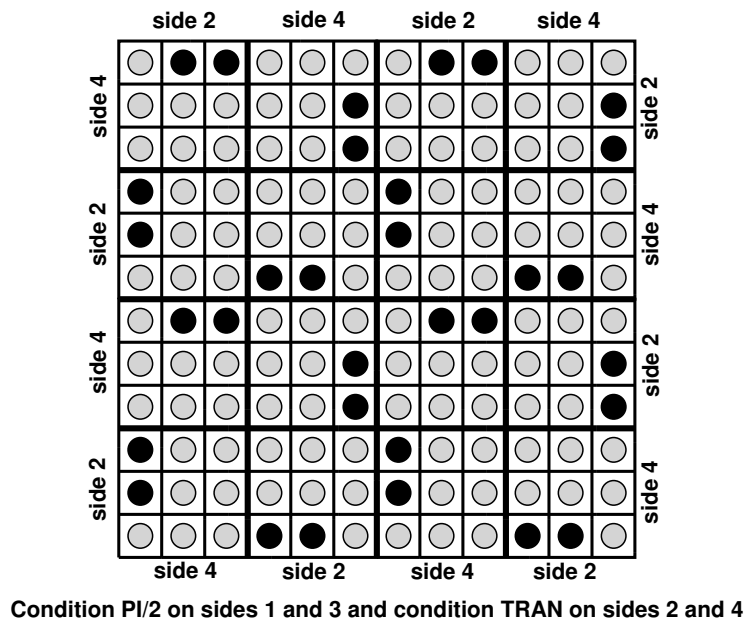
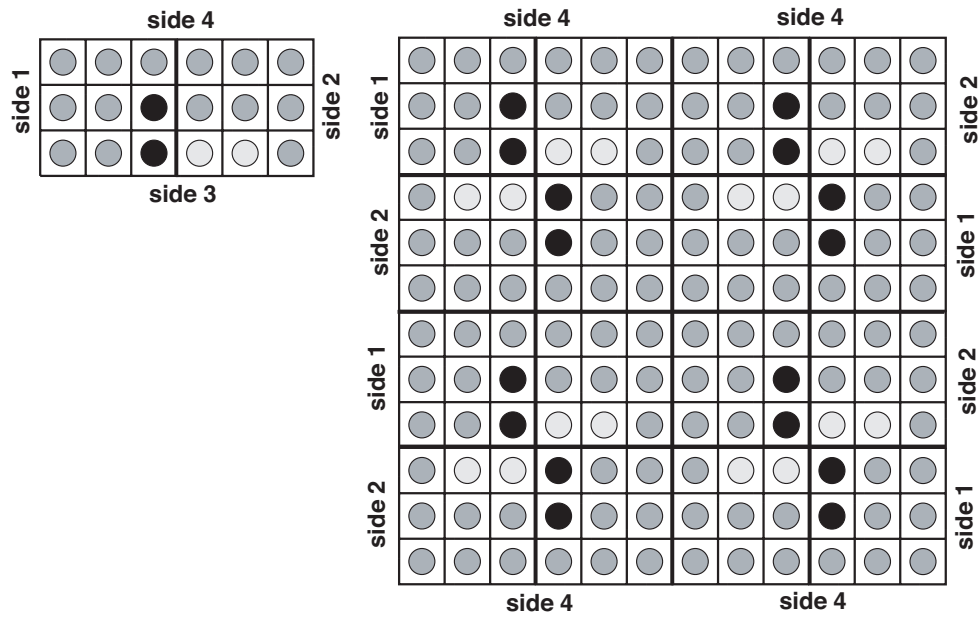

Figure 4: Translation/rotation boundary conditions in Cartesian geometry



Condition PI on side 3 and TRAN on sides 1, 2 and 4

Figure 5: Representing a checkerboard in Cartesian geometry

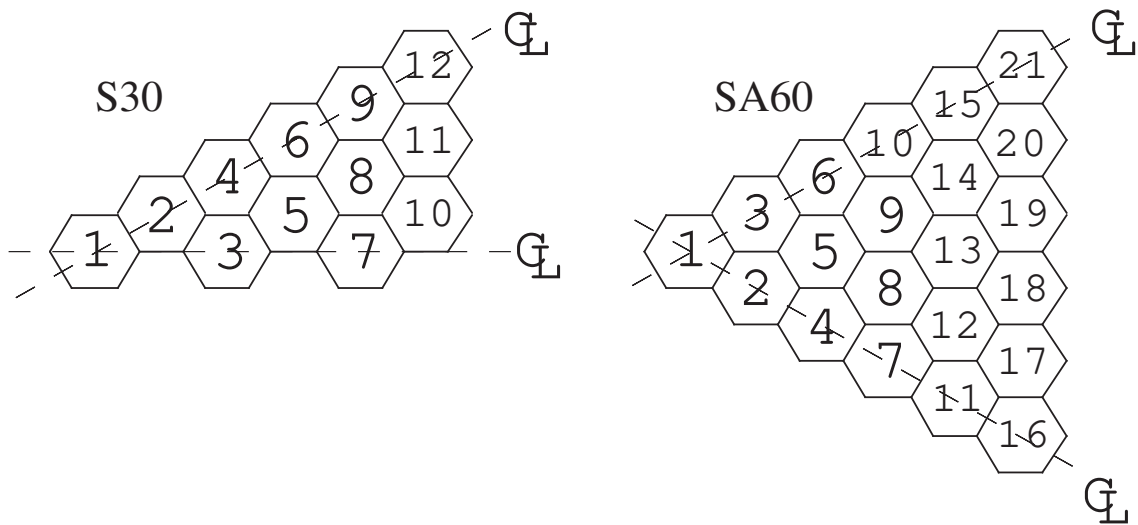

Figure 6: Hexagonal geometries of type S30 and SA60

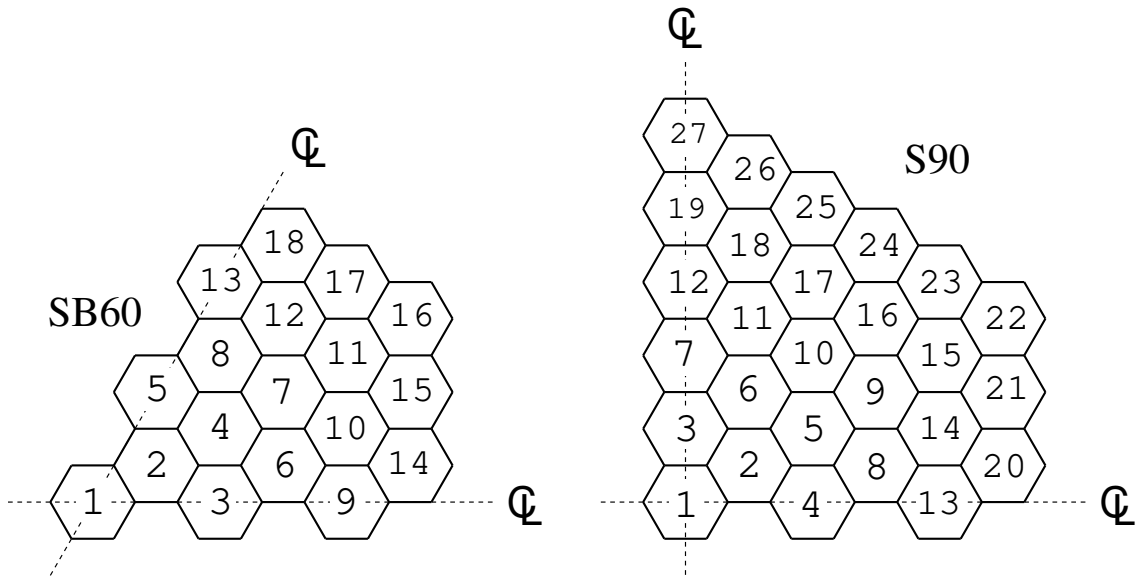

Figure 7: Hexagonal geometries of type SB60 and S90

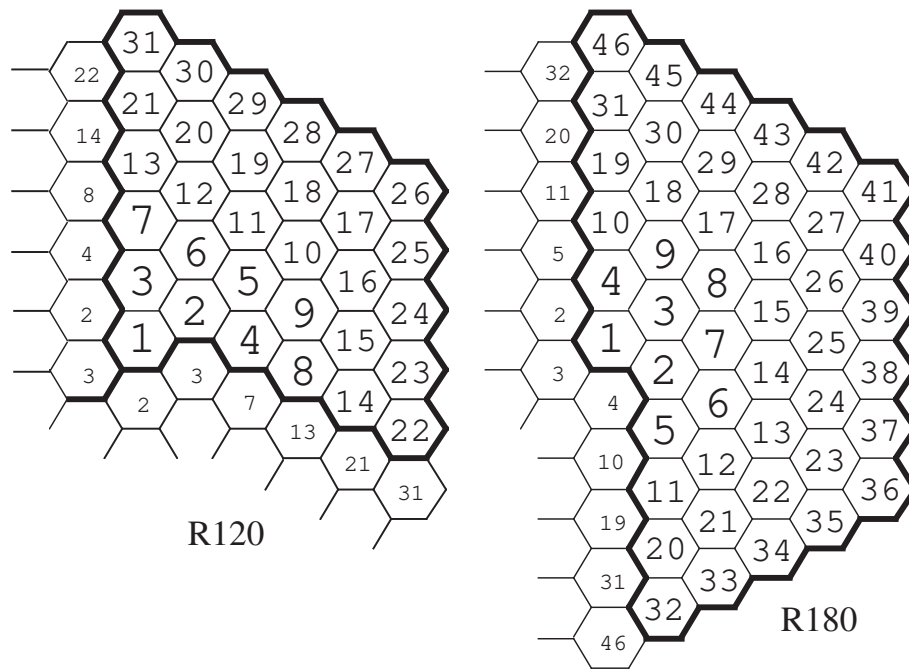

Figure 8: Hexagonal geometries of type R120 and R180

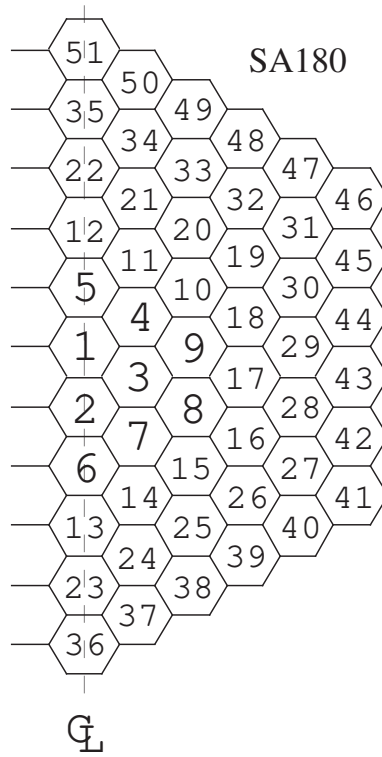

Figure 9: Hexagonal geometry of type SA180

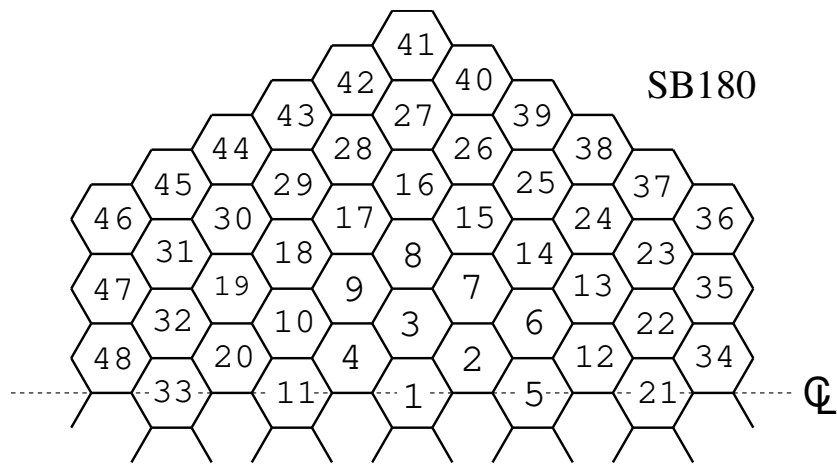

Figure 10: Hexagonal geometry of type SB180

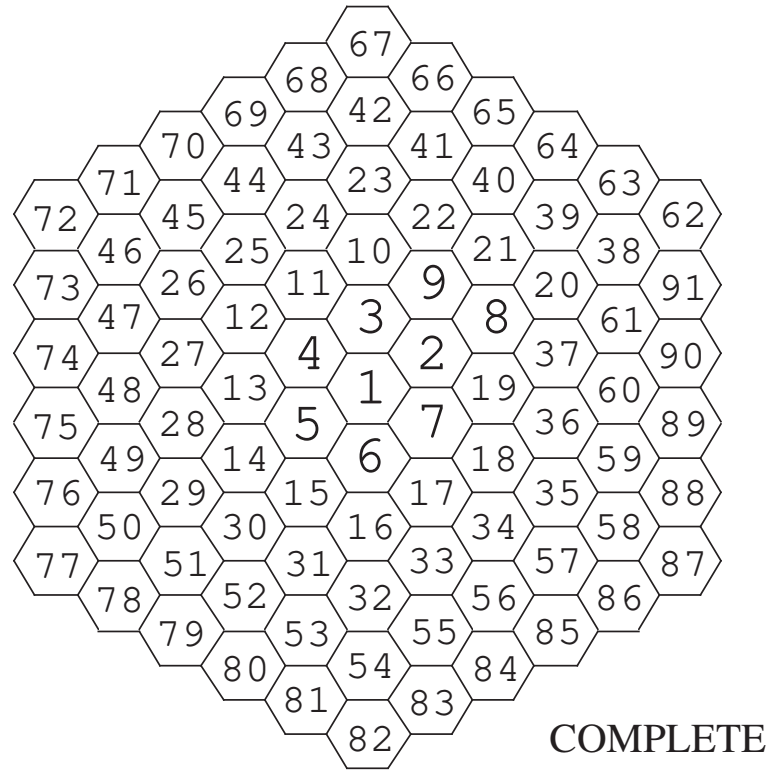

Figure 11: Hexagonal geometry of type COMPLETE

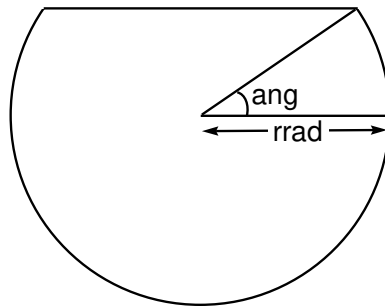

Figure 12: Cylindrical correction in Cartesian geometry

## 3.3.3 Spatial properties of geometry

The (**descSP**) structure has the following contents:

Table 19: Structure (**descSP**)

```
[ MESHX (xxx(i), i=1,lx+1) ]
[ SPLITX (ispltx(i), i=1,lx) ]
[ MESHY (yyy(i), i=1,ly+1) ]
[ SPLITY (isply(i), i=1,ly) ]
[ MESHZ (zzz(i), i=1,lz+1) ]
[ SPLITZ (ispltz(i), i=1,lz) ]
[ RADIUS (rrr(i), i=1,lr+1) ]
[ OFFCENTER (disxyz(i), i=1,3) ]
[ SPLITR (ispltr(i), i=1,lr) ]
[ SECT isect [ jsect ] ]
[ SIDE sideh [ hexmsh ] ]
[ { SPLITH isplth | SPLITL ispltl } ]
[ { NPIN npins
  { [ RPIN { rpins | (rpins(i), i=1, npins) } ]
    [ APIN { apins | (apins(i), i=1, npins) } ] |
    [ CPINX (xpins(i), i=1, npins) ]
    [ CPINY (ypins(i), i=1, npins) ]
    [ CPINZ (zpins(i), i=1, npins) ] }
  | DPIN dpins } ]
```

|        |  |
|--------|--|
| MESHX  | keyword to specify the spatial mesh defining the regions along the $X$ -axis.  |
| xxx    | array giving the $X$ limits (cm) of the regions making up the geometry. These values must be given in order, from $X^-$ to $X^+$ . If the geometry presents a diagonal symmetry the same data is also used along the $Y$ -axis.          |
| SPLITX | keyword to specify that a mesh splitting of the geometry along the $X$ -axis is to be performed.   |
| ispltx | array giving the number of zones that will be considered for each region along the $X$ -axis. If the geometry presents a diagonal symmetry this information is also used for the splitting along the $Y$ -axis. By default, $ispltx=1$ . |
| MESHY  | keyword to specify the spatial mesh defining the regions along the $Y$ -axis.  |
| yyy    | array giving the $Y$ limits (cm) of the regions making up the geometry. These values must be given in order, from $Y^-$ to $Y^+$ .   |
| SPLITY | keyword to specify that a mesh splitting of the geometry along the $Y$ -axis is to be performed.   |
| isply  | array giving the number of zones that will be considered for each region along the $Y$ -axis. By default, $isply=1$ unless a diagonal symmetry is used in which case $isply=ispltx$ .  |
| MESHZ  | keyword to specify the spatial mesh defining the regions along the $Z$ -axis.  |
| zzz    | array giving the $Z$ limits (cm) of the regions making up the geometry. These values must be given in order, from $Z^-$ to $Z^+$ .   |

|               |   |
|---------------|---|
| SPLITZ        | keyword to specify that a mesh splitting of the geometry along the $Z$ -axis is to be performed.  |
| <i>ispltz</i> | array giving the number of zones that will be considered for each region along the $Z$ -axis. By default, <i>ispltz</i> =1.   |
| RADIUS        | keyword to specify the spatial mesh along the radial direction.   |
| <i>rrr</i>    | array giving the radial limits (cm) of the annular regions (cylindrical or spherical) making up the geometry. It is used for the following geometries: TUBE, TUBEZ, SPHERE), CARCEL, CARCELX, CARCELY, CARCELZ, HEXCEL and HEXCELZ. It is important to note that we must have <i>rrr</i> (1)=0.0. The other values of <i>rrr</i> ( <i>i</i> ) in a CARCEL- or HEXCEL-type geometry are defined as shown in Figure 13.                                 |
| OFFCENTER     | keyword to specify that the concentric annular regions in a CARCEL, CARCELX, CARCELY, CARCELZ, TUBE, TUBEX, TUBEY and TUBEZ geometry can now be displaced with respect to the center of the Cartesian mesh. This option will only be treated when the EXCELT:, NXT: and EXCELL: modules are used.   |
| <i>disxyz</i> | array giving the $x$ ( <i>disxyz</i> (1)), $y$ ( <i>disxyz</i> (2)) and $z$ ( <i>disxyz</i> (3)) displacement (cm) of the concentric annular regions with respect to the center of the Cartesian mesh.  |
| SPLITR        | keyword to specify that a mesh splitting of the geometry along the radial direction is to be performed.   |
| <i>ispltr</i> | array giving the number of zones that will be considered for each region along the radial axis. A negative value results in a splitting of the regions into zones of equal volumes; a positive value results in a uniform splitting along the radial direction. By default, <i>ispltr</i> =1.   |
| SECT          | keyword to specify the type of sectorization for a Cartesian or hexagonal cell. In hexagonal geometry, this keyword is expected to be defined near the SIDE keyword. By default, no sectorization is performed.   |
| <i>isect</i>  | sectorization index, defined as $isect = \begin{cases} -999 : & \text{non-sectorized cell processed as a sectorized cell} \\ -1 : & \text{\times-type sectorization} \\ 0 : & \text{non-sectorized cell} \\ 1 : & \text{+-type sectorization} \\ 2 : & \text{simultaneous \times- and +-type sectorization} \\ 3 : & \text{simultaneous \times- and +-type sectorization shifted by } 22.5^\circ \\ 4 : & \text{windmill sectorization.} \end{cases}$ |
| <i>jsect</i>  | number of embedded tubes that are <i>not</i> sectorized, with $0 \leq jsect \leq lr$ . By default, <i>jsect</i> = 0. Examples of sectorization options are depicted in Figs. 14 and 15.   |
| SIDE          | keyword to specify the length of a side of a hexagon.   |
| <i>sideh</i>  | length of one side of a hexagon (cm).   |
| <i>hexmsh</i> | triangular mesh for HEXT, HEXTCEL, HEXTZ and HEXTCELZ hexagonal geometries. By default, <i>hexmsh</i> = <i>sideh</i> / <i>nhr</i> . When <i>hexmsh</i> is provided, it is used instead of the default value with the following constraints $sideh \leq nhr \times hexmsh < sideh + hexmsh$  |
|               | The triangles in the last hexagonal ring are truncated at <i>sideh</i> (see Figure 16).   |
| SPLITH        | keyword to specify that a triangular mesh splitting of the hexagonal geometry is to be performed – for HEX, HEXZ, HEXT, HEXTCEL, HEXTZ and HEXTCELZ type geometries. This is valid only if <i>nhr</i> =1.   |



|               |   |
|---------------|---|
| <i>isplth</i> | value of the triangular mesh splitting. Its use is similar to <i>nh</i> except that each sector of the hexagonal cell will be filled by a unique mixture. The number of triangles per hexagon is given by $6 \times isplth^2$ . <i>isplth</i> = 0 is used for full hexagon discretization.        |
| SPLITL        | keyword to specify that a lozenge mesh splitting of the hexagonal geometry is to be performed – for HEX and HEXZ type geometries.   |
| <i>ispltl</i> | value of the lozenge splitting. The number of lozenges per hexagon is given by $3 \times ispltl^2$ .  |
| NPIN          | keyword to specify the number of pins located in a cluster geometry. It can only be used for SPHERE, TUBE, TUBEX, TUBEY and TUBEZ sub-geometry.   |
| <i>npins</i>  | the number of pins associated with this sub-geometry in the primary geometry.   |
| DPIN          | keyword to specify the pin density in a geometry that contains clusters. A number $N_{p,r}$ of pins that will be placed randomly in the geometry with   |
|               | $N_{p,r} = \text{NINT} \left( \frac{d_{p,r} V_c}{V_p} \right)$  |
|               | where $d_{p,r}$ is the pin density, $V_g$ the volume of the cell containing these pins and $V_p$ the volume of this pin type. The function NINT() provides the nearest integer associated with its real argument. It can only be used for SPHERE, TUBE, TUBEX, TUBEY and TUBEZ sub-geometry.      |
| <i>dpins</i>  | the pin density $d_{p,r}$ .   |
| RPIN          | keyword to specify the radius of an imaginary cylinder where the centers of the pins are to be placed in a cluster geometry.  |
| <i>rpins</i>  | the radius (cm) of an imaginary cylinder where the centers of the pins are to be placed. In the case where a single value is provided for <i>rpins</i> , all the pins are located at the same distance from the center of the cell (taking account the offset provided by the keyword OFFCENTER). |
| APIN          | keyword to specify the angle of the first pin or each pin centered on an imaginary cylinder in a cluster geometry.  |
| <i>apins</i>  | the angle (radian) of the first pin in the ring (only one value provided for <i>apins</i> , the angular spacing of the pins being $2\pi/npins$ ) or the angle of each pins in the ring.   |
| CPINX         | keyword to specify the $x$ position where the centers of the pins are to be placed in a cluster geometry.   |
| <i>xpins</i>  | the $x$ position (cm) where the centers of the pins are to be placed.   |
| CPINY         | keyword to specify the $y$ position where the centers of the pins are to be placed in a cluster geometry.   |
| <i>ypins</i>  | the $y$ position (cm) where the centers of the pins are to be placed.   |
| CPINZ         | keyword to specify the $z$ position where the centers of the pins are to be placed in a cluster geometry.   |
| <i>zpins</i>  | the $z$ position (cm) where the centers of the pins are to be placed.   |

The user should be warned that the maximum number of zones resulting from the above description of a geometry  $L_{zones}$  should not exceed the limits imposed by *maxreg* and defined in the tracking module

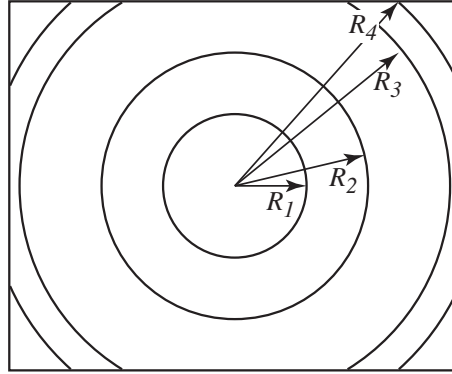

Figure 13: Definition of the radii in a CARCEL- or HEXCEL-type geometry

SYBILT:, NXT: or EXCELT: (see Section 3.4). For pure geometry with splitting we can define the variables  $L_x$ ,  $L_y$ ,  $L_z$ ,  $L_r$ ,  $L_h$  and  $L_t$  as:

$$\begin{aligned}
 L_x &= \sum_{i=1}^{l_x} ispltx(i) \\
 L_y &= \sum_{i=1}^{l_y} isply(i) \\
 L_z &= \sum_{i=1}^{l_z} isplz(i) \\
 L_r &= \sum_{i=1}^{l_r} |isplr(i)| \\
 L_h &= lh \\
 L_t &= \begin{cases} 6 \times nhr^2 & \text{if } nhr \leq 1 \\ 6 \times isplth^2 & \text{otherwise} \end{cases}
 \end{aligned}$$

and  $L_{zones}$  will be given by:

- SPHERE geometry.

$$L_{zones} = L_r$$

- TUBE geometry.

$$L_{zones} = L_x L_y L_r$$

- TUBEX geometry.

$$L_{zones} = L_x L_y L_z L_r$$

- TUBEY geometry.

$$L_{zones} = L_x L_y L_z L_r$$

- TUBEZ geometry.

$$L_{zones} = L_x L_y L_z L_r$$

- CAR1D geometry.

$$L_{\text{zones}} = L_x$$

- CAR2D geometry
  - without diagonal symmetry.

$$L_{\text{zones}} = L_x L_y$$

- with diagonal symmetry.

$$L_{\text{zones}} = \frac{L_x(L_y + 1)}{2} = \frac{(L_x + 1)L_y}{2}$$

- CARCEL geometries.

$$L_{\text{zones}} = L_x L_y (L_r + 1)$$

- CAR3D geometry
  - without diagonal symmetry.

$$L_{\text{zones}} = L_x L_y L_z$$

- with diagonal symmetry.

$$L_{\text{zones}} = \frac{L_x(L_y + 1)L_z}{2} = \frac{(L_x + 1)L_y L_z}{2}$$

- CARCELY geometry.

$$L_{\text{zones}} = L_x L_y L_z (L_r + 1)$$

- CARCELY geometry.

$$L_{\text{zones}} = L_x L_y L_z (L_r + 1)$$

- CARCELZ geometries.

$$L_{\text{zones}} = L_x L_y L_z (L_r + 1)$$

- HEX geometry.

$$L_{\text{zones}} = L_h$$

- HEXT geometry.

$$L_{\text{zones}} = L_t$$

- HEXCEL geometries.

$$L_{\text{zones}} = (L_r + 1)$$

- HEXTCEL geometries.

$$L_{\text{zones}} = L_t$$

- HEXZ geometry.

$$L_{\text{zones}} = L_z L_h$$

- HEXTZ geometry.

$$L_{\text{zones}} = L_z L_t$$

- HEXCELZ geometries.

$$L_{\text{zones}} = L_z(L_r + 1)$$

- HEXTCELZ geometries.

$$L_{\text{zones}} = L_z L_t (L_r + 1)$$

For cluster geometries, only one region is associated with each zone in a pin even if this pin is repeated  $npins$  times.

For mixed geometries, it is important to ensure that  $L_{\text{zones}}$  which represents the sum over all the sub-geometries of the total number of regions  $L_t^i$  associated with each pure sub-geometry  $i$  computed using the technique described above. For cluster geometries, only one region is associated with each zone in a pin even if this pin is repeated  $npins$  times.

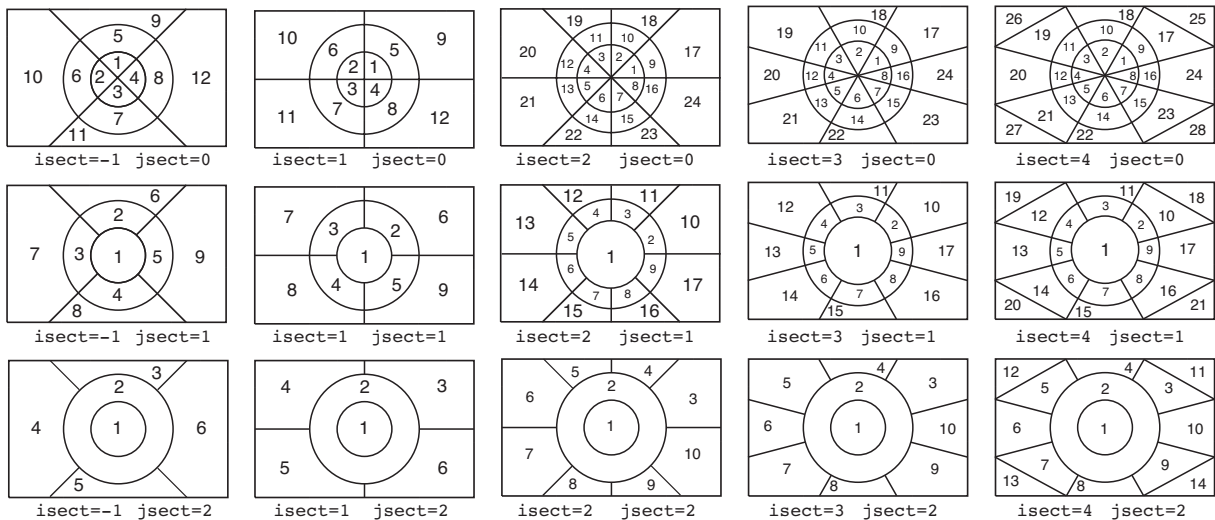

Figure 14: Numerotation of the sectors in a Cartesian cell

### 3.3.4 Physical properties of geometry

In addition to specifying the mixture associated with each region in the geometry, the (**descPP**) structure is also used to provide information on the sub-geometry required in this geometry. For example,

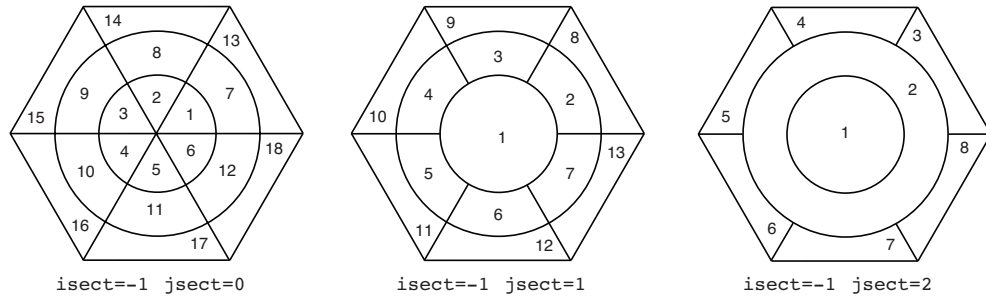

Figure 15: Numerotation of the sectors in an hexagonal cell

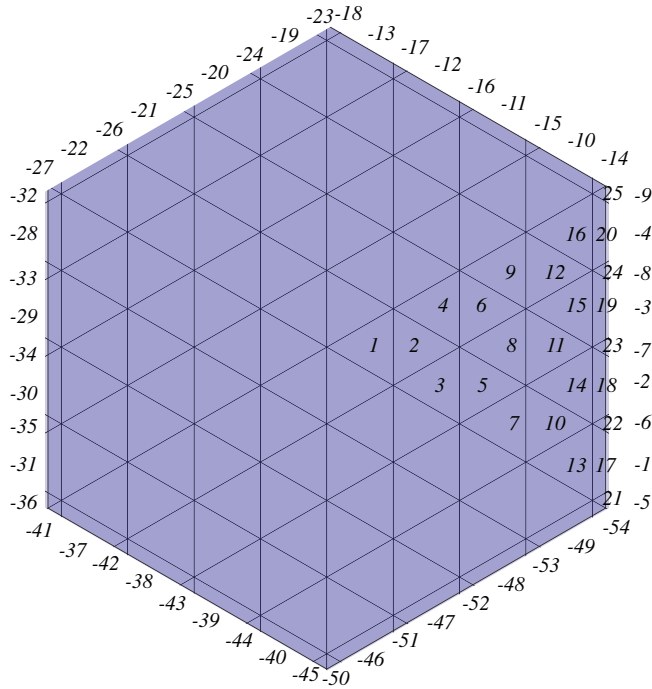

Figure 16: Hexagonal geometry with triangular mesh that extends past the hexagonal boundary

an optional procedure in DRAGON groups together regions so as to reduce the number of unknowns *maxreg* in the flux calculation. In this way, only the merged regions contribute to the cost of the calculation. However, the following points must be considered:

1. All the cells belonging to the same merged region must have the same nuclear properties and dimensions.
2. The grouping procedure is based on the approximation that all the regions belonging to the same

merged region share the same flux.

3. The merging can also take into account region orientation (by a rotation and/or transposition) before they are merged. This procedure facilitates the merging of regions when a **DIAG** or **SYME** boundary condition is used.

The (**descPP**) structure has the following contents:

Table 20: Structure (**descPP**)

```
[ MIX { (imix(i),i=1,nt) [ REPEAT ] |
  [[ PLANE iplan { (imix(i),i=1,lp) | SAME iplan1
  | [[ CROWN { (imix(i),i=1,lc) | ALL jmix | SAME iplan1 } ]]
  | [[ UPTO ic ALL jmix | SAME iplan1 } ]] ] ] }
]
[ HMIX (ihmix(i), i=1,Nt) [ REPEAT ] ]
[ CELL (HCELL(i),i=1,Nt) ]
[ MERGE (imerge(i),i=1,Nt) ]
[ TURN (HTURN(i),i=1,Nt) ]
[ CLUSTER (NAMPIN(i),i=1,Np) ]
[ MIX-NAMES (NAMMIX(i),i=1,maxmix) ]
```

Here  $N_p$  is the number of pin types in the cluster. In addition to the real (physical) mixture *imix* present in a given region of space and specified by the keyword **MIX**, a virtual mixture *ihmix* can also be provided using the keyword **HMIX**. This mixture can be used to identify the regions that will be combined in the **EDI**: module to create homogenized region *ihmix* (see Section 3.7). Here  $N_t$  is computed in a way similar to  $L_{zones}$  namely

- SPHERE geometry.

$$N_t = lr$$

The mixtures are then given in the following order

1. radially outward ( $l = 1, lr$ ).

- TUBE geometry.

$$N_t = lr \times lx \times ly$$

The mixtures are then given in the following order

1. radially outward ( $l = 1, lr$ ) and such that *imix* is arbitrary (not used) if radial region  $l$  does not intersect Cartesian region  $(i, j)$ ;
2. from surface **X-** to surface **X+** ( $i = 1, lx$  for each  $j$ );
3. from surface **Y-** to surface **Y+** ( $j = 1, ly$ ).

- TUBEX geometry.

$$N_t = lr \times ly \times lz \times lx$$

The mixtures are then given in the following order

1. radially outward ( $l = 1, lr$ ) and such that *imix* is arbitrary (not used) if radial region  $l$  does not intersect Cartesian region  $(j, k, i)$ ;
2. from surface Y- to surface Y+ ( $j = 1, ly$  for each  $k$  and  $i$ );
3. from surface Z- to surface Z+ ( $k = 1, lz$  for each  $i$ );
4. from surface X- to surface X+ ( $i = 1, lx$ ).

- TUBEY geometry.

$$N_t = lr \times lz \times lx \times ly$$

The mixtures are then given in the following order

1. radially outward ( $l = 1, lr$ ) and such that *imix* is arbitrary (not used) if radial region  $l$  does not intersect Cartesian region  $(k, i, j)$ ;
2. from surface Z- to surface Z+ ( $k = 1, lz$  for each  $i$  and  $j$ );
3. from surface X- to surface X+ ( $i = 1, lx$  for each  $j$ );
4. from surface Y- to surface Y+ ( $j = 1, ly$ ).

- TUBEZ geometry.

$$N_t = lr \times lx \times ly \times lz$$

The mixtures are then given in the following order

1. radially outward ( $l = 1, lr$ ) and such that *imix* is arbitrary (not used) if radial region  $l$  does not intersect Cartesian region  $(i, j, k)$ ;
2. from surface X- to surface X+ ( $i = 1, lx$  for each  $j$  and  $k$ );
3. from surface Y- to surface Y+ ( $j = 1, ly$  for each  $k$ );
4. from surface Z- to surface Z+ ( $k = 1, lz$ ).

- CAR1D geometry.

$$N_t = lx$$

The mixtures are then given in the following order

1. from surface X- to surface X+ ( $i = 1, lx$ ).

- CAR2D geometry

- without diagonal symmetry.

$$N_t = lx \times ly$$

The mixtures or cells are then given in the following order

1. from surface X- to surface X+ ( $i = 1, lx$  for each  $j$ );
2. from surface Y- to surface Y+ ( $j = 1, ly$ ).

- with diagonal symmetry (X- and Y+).

$$N_t = \frac{lx \times (lx + 1)}{2}$$

The mixtures or cells are then given in the following order

1. from surface X- to surface X+ ( $i = j, lx$  for each  $j$ );
2. from surface Y- to surface Y+ ( $j = 1, ly$ ).

– with diagonal symmetry (X+ and Y-).

$$N_t = \frac{lx \times (lx + 1)}{2}$$

The mixtures or cells are then given in the following order

1. from surface X- to surface X+ ( $i = 1, j$  for each  $j$ );
2. from surface Y- to surface Y+ ( $j = 1, ly$ ).

- CARCEL geometries.

$$N_t = (lr + 1) \times lx \times ly$$

The mixtures are then given in the following order

1. radially outward ( $l = 1, lr$ ) and such that *imix* is arbitrary (not used) if radial region  $l$  does not intersect Cartesian region ( $i, j$ );
2.  $l = lr+1$  for the mixture outside the annular regions but inside Cartesian region ( $i, j$ );
3. from surface X- to surface X+ ( $i = 1, lx$  for each  $j$ );
4. from surface Y- to surface Y+ ( $j = 1, ly$ ).

- CAR3D geometry

– without diagonal symmetry.

$$N_t = lx \times ly \times lz$$

The mixtures or cells are then given in the following order

1. from surface X- to surface X+ ( $i = 1, lx$  for each  $j$  and  $k$ );
2. from surface Y- to surface Y+ ( $j = 1, ly$  for  $k$ );
3. from surface Z- to surface Z+ ( $k = 1, lz$ ).

– with diagonal symmetry (X- and Y+).

$$N_t = \frac{lx \times (lx + 1)}{2} \times lz$$

The mixtures or cells are then given in the following order

1. from surface X- to surface X+ ( $i = j, lx$  for each  $j$  and  $k$ );
2. from surface Y- to surface Y+ ( $j = 1, ly$  for each  $k$ );
3. from surface Z- to surface Z+ ( $k = 1, lz$ ).

– with diagonal symmetry (X+ and Y-).

$$N_t = \frac{lx \times (lx + 1)}{2} \times lz$$

The mixtures or cells are then given in the following order

1. from surface X- to surface X+ ( $i = 1, j$  for each  $j$  and  $k$ );
2. from surface Y- to surface Y+ ( $j = 1, ly$  for each  $k$ );
3. from surface Z- to surface Z+ ( $k = 1, lz$ ).

- CARCELX geometry.

$$N_t = (lr + 1) \times ly \times lz \times lx$$

The mixtures are then given in the following order



1. radially outward ( $l = 1, lr$ ) and such that  $imix$  is arbitrary (not used) if radial region  $l$  does not intersect Cartesian region  $(j, k, i)$ ;
2.  $l = lr+1$  for the mixture outside the annular regions but inside Cartesian region  $(j, k, i)$ ;
3. from surface Y- to surface Y+ ( $j = 1, ly$  for each  $k$  and  $i$ );
4. from surface Z- to surface Z+ ( $k = 1, lz$  for each  $i$ );
5. from surface X- to surface X+ ( $i = 1, lx$ ).

- CARCELY geometry.

$$N_t = (lr + 1) \times lz \times lx \times ly$$

The mixtures are then given in the following order

1. radially outward ( $l = 1, lr$ ) and such that  $imix$  is arbitrary (not used) if radial region  $l$  does not intersect Cartesian region  $(k, i, j)$ ;
2.  $l = lr+1$  for the mixture outside the annular regions but inside Cartesian region  $(k, i, j)$ ;
3. from surface Z- to surface Z+ ( $k = 1, lz$  for each  $i$  and  $j$ );
4. from surface X- to surface X+ ( $i = 1, lx$  for each  $j$ );
5. from surface Y- to surface Y+ ( $j = 1, ly$ ).

- CARCELZ geometries.

$$N_t = (lr + 1) \times lx \times ly \times lz$$

The mixtures are then given in the following order

1. radially outward ( $l = 1, lr$ ) and such that  $imix$  is arbitrary (not used) if radial region  $l$  does not intersect Cartesian region  $(i, j, k)$ ;
2.  $l = lr+1$  for the mixture outside the annular regions but inside Cartesian region  $(i, j, k)$ ;
3. from surface X- to surface X+ ( $i = 1, lx$  for each  $j$  and  $k$ );
4. from surface Y- to surface Y+ ( $j = 1, ly$  for each  $k$ );
5. from surface Z- to surface Z+ ( $k = 1, lz$ ).

- HEX geometry.

$$N_t = lh$$

The mixtures or cells are then given in the order provided in Figure 6 to 11.

- HEXT geometry.

Three options are possible here:

- All the triangles in an hexagonal crown have the same mixture. In this case

$$N_t = nhr$$

and the real and virtual mixtures are given from each crown starting at the center of the cell.

- All the triangles in an hexagonal crown in a given sector have the same mixture. In this case

$$N_t = 6 \times nhr$$

and the real and virtual mixtures are given in the following order

1. from each crown in sector  $j$  starting from the center of the cell;
2. for each sector  $j = 1, 6$ .

- All the triangles contain a different mixture. In this case

$$N_t = 6 \times nhr^2$$

and the real and virtual mixtures are given in the following order

1. from each triangle  $l$  ( $l = 1, 2 \times nhc - 1$ ) in hexagonal crown  $i$  of sector  $j$ . Figure 1 illustrates region and surface ordering in the case where the default value of *hexmsh* is used and Figure 16 the same information when a different value of *hexmsh* is provided.
2. from each crown in sector  $j$  starting from the center of the cell;
3. for each sector  $j = 1, 6$ .

- HEXCEL geometries.

$$N_t = (lr + 1)$$

The mixtures are then given in the following order

1. radially outward ( $l = 1, lr$ );
2.  $l = lr+1$  for the mixture outside the annular regions but inside the hexagonal region.

- HEXZ geometry.

$$N_t = lh \times lz$$

The mixtures or cells are then given in the following order

1. according to Figure 6 to 11 for plane  $k$ ;
2. from surface Z- to surface Z+ ( $k = 1, lz$ ).

- HEXTCEL geometries.

Three options are possible here:

- All the triangles in an hexagonal crown have the same mixture. In this case

$$N_t = (lr + 1) \times nhr$$

and the real and virtual mixtures are given in the following order

1. radially outward ( $l = 1, lr + 1$ ) for each crown ( $l = lr + 1$  is for the part of crown outside the annular regions);
2. from each crown starting from the center of the cell.

- All the triangles in an hexagonal crown in a given sector have the same mixture. In this case

$$N_t = 6 \times (lr + 1) \times nhr$$

and the real and virtual mixtures are given in the following order

1. radially outward ( $l = 1, lr + 1$ ) for each crown of each sector ( $l = lr + 1$  is for the part of crown outside the annular regions);
2. from each crown in sector  $j$  starting from the center of the cell;
3. for each sector  $j = 1, 6$ .

- All the triangles contain a different mixture. In this case

$$N_t = 6 \times (lr + 1) \times nhr^2$$

and the real and virtual mixtures are given in the following order

1. radially outward ( $l = 1, lr+1$ ) for each triangle ( $l = lr+1$  is for the part of triangle outside the annular regions);
2. from each triangle  $l$  ( $l = 1, 2 \times nhc - 1$ ) in hexagonal crown  $i$  of sector  $j$ . Figure 1 illustrates region and surface ordering in the case where the default value of *hexmsh* is used and Figure 16 the same information when a different value of *hexmsh* is provided.
3. from each crown in sector  $j$  starting from the center of the cell;
4. for each sector  $j = 1, 6$ .

- HEXTZ geometry.

Three options are again possible here:

- All the triangles in an hexagonal crown in a plane have the same mixture. In this case

$$N_t = nhr \times lz$$

and the real and virtual mixtures are given in the following order

1. from each crown starting from the center of the cell;
  2. from lowest (Z-) to highest (Z+) plane ( $k = 1, lz$ ).
- All the triangles in an hexagonal crown in a given sector in a plane have the same mixture. In this case

$$N_t = 6 \times nhr \times lz$$

and the real and virtual mixtures are given in the following order

1. from each crown in sector  $j$  starting from the center of the cell;
  2. for each sector  $j = 1, 6$ ;
  3. from lowest (Z-) to highest (Z+) plane ( $k = 1, lz$ ).
- All the triangles contain a different mixture. In this case

$$N_t = 6 \times nhr^2 \times lz$$

and the real and virtual mixtures are given in the following order

1. from each triangle  $l$  ( $l = 1, 2 \times nhc - 1$ ) in hexagonal crown  $i$  of sector  $j$ . Figure 1 illustrates region and surface ordering in the case where the default value of *hexmsh* is used and Figure 16 the same information when a different value of *hexmsh* is provided.
2. from each crown in sector  $j$  starting from the center of the cell;
3. for each sector  $j = 1, 6$ ;
4. from lowest (Z-) to highest (Z+) plane ( $k = 1, lz$ ).

- HEXCELZ geometries.

$$N_t = (lr + 1) \times lz$$

- HEXTCELZ geometries.

Three options are possible here:

- All the triangles in an hexagonal crown have the same mixture. In this case

$$N_t = (lr + 1) \times nhr \times lz$$

and the real and virtual mixtures are given in the following order

1. radially outward ( $l = 1, lr + 1$ ) for each crown ( $l = lr + 1$  is for the part of crown outside the annular regions);
2. from each crown starting from the center of the cell;
3. from lowest (Z-) to highest (Z+) plane ( $k = 1, lz$ ).

- All the triangles in an hexagonal crown in a given sector have the same mixture. In this case

$$N_t = 6 \times (lr + 1) \times nhr \times lz$$

and the real and virtual mixtures are given in the following order

1. radially outward ( $l = 1, lr + 1$ ) for each crown of each sector ( $l = lr + 1$  is for the part of crown outside the annular regions);
  2. from each crown in sector  $j$  starting from the center of the cell;
  3. for each sector  $j = 1, 6$ ;
  4. from lowest (Z-) to highest (Z+) plane ( $k = 1, lz$ ).
- All the triangles contain a different mixture. In this case

$$N_t = 6 \times (lr + 1) \times nhr^2 \times lz$$

and the real and virtual mixtures are given in the following order

1. radially outward ( $l = 1, lr + 1$ ) for each triangle ( $l = lr + 1$  is for the part of triangle outside the annular regions);
2. from each triangle  $l$  ( $l = 1, 2 \times nhc - 1$ ) in hexagonal crown  $i$  of sector  $j$ . Figure 1 illustrates region and surface ordering in the case where the default value of *hexmsh* is used and Figure 16 the same information when a different value of *hexmsh* is provided.
3. from each crown in sector  $j$  starting from the center of the cell;
4. for each sector  $j = 1, 6$ ;
5. from lowest (Z-) to highest (Z+) plane ( $k = 1, lz$ ).

The mixtures are then given in the following order

1. radially outward ( $l = 1, lr$ ) for plane  $k$ ;
2.  $l = lr + 1$  for the mixture outside the annular regions but inside the hexagonal region on plane  $k$ ;
3. from surface Z- to surface Z+ ( $k = 1, lz$ ).

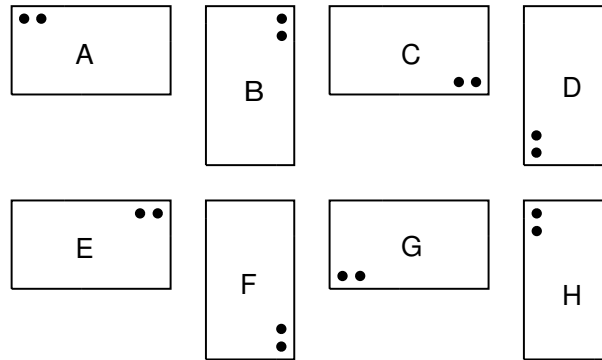

Figure 17: Description of the various rotations allowed for Cartesian geometries

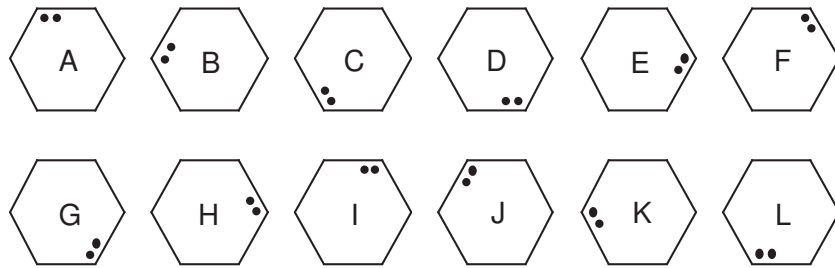

Figure 18: Description of the various rotation allowed for hexagonal geometries

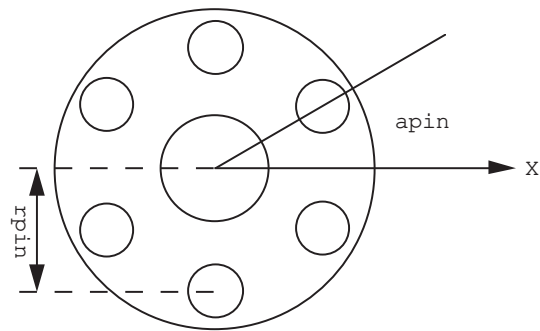

Figure 19: Typical cluster geometry

The inputs associated with this structure have the following meaning:

**MIX** keyword to specify the isotopic mixture number or sub-geometry associated with each region inside the geometry. When diagonal symmetries are considered, only the mixture associated with regions inside the symmetrized geometry need to be specified. When a sub-geometry is located inside symmetrized geometry but outside the calculation region it must be declared *virtual* (for example, the corners of a nuclear reactor).

**imix** array of  $n_t \leq N_t$  integers or character variables associated with each region. An integer is a mixture number associated with a region  $imix \leq maxmix$  (see Sections 3.1 and 3.2). If  $imix=0$ , the corresponding volume is replaced by a void region. If  $imix$  is a character variable, it is replaced by the corresponding sub-geometry or *generating cell*. These values must be specified in the following order for most geometries:

1. radially from the inside out.
2. from surface X- to surface X+
3. from surface Y- to surface Y+
4. from surface Z- to surface Z+

In the cases where a CARCELX and a TUBEX geometry are defined then we will use

1. radially from the inside out ( $lr + 1$  mixtures for CARCELX and  $lr$  for TUBEX).
2. from surface Y- to surface Y+
3. from surface Z- to surface Z+
4. from surface X- to surface X+

Finally, for a CARCELY and TUBEY geometry are defined the following order is considered:

1. radially from the inside out ( $lr + 1$  mixtures for CARCELY and  $lr$  for TUBEY)
2. from surface Z- to surface Z+
3. from surface X- to surface X+
4. from surface Y- to surface Y+

In the cases where a sectorized cell geometry is defined, *imix* must be defined in each sector, following the order shown in Figure 14 and 15. Also note that *imix* is *not affected* by the values of the mesh-splitting indices *ispltx*, *isply*, *ispltz* or *ispltr*.

**REPEAT** keyword to specify the previous list of mixtures will be repeated. This is valid only when  $N_t/n_t$  is an integer. If this keyword is absent and  $n_t < N_t$ , then the missing mixtures will be replaced with void ( $imix(i) = 0$ ).

**PLANE** keyword to attribute mixture numbers to each volume inside a single 2-D plane. This option is valid only for 3-D geometries, Cartesian or hexagonal.

**iplan** plane number for which material mixture are input.

**SAME** keyword to attribute the same material mixture numbers of the *iplan1* plane to the *iplan* plane. In hexagonal geometry, it can indicate that the mixture numbers of the current crown of the *iplanth* plane will be identical to those of the same crown of the *iplan1*th plane.

**iplan1** plane number used as reference to input the current plane or crown(s).

**lp** number of volumes in a plane. In Cartesian geometry,  $lp = lx * ly$  and in hexagonal geometry,  $lp = lh$ .

|               |   |
|---------------|---|
| CROWN         | keyword to attribute mixture numbers to each hexagon of a single crown. This option is only valid for COMPLETE hexagonal geometry definition. Each use of the keyword CROWN increases the crown number by 1. So it is not required to give its number, but crowns must be defined from the center to the peripheral regions of a plane.   |
| <i>lc</i>     | number of hexagons in the current crown. For the <i>i</i> th crown of a complete hexagonal plane, $lc = (i - 1) * 6$ . The first crown is composed of only one hexagon.   |
| ALL           | keyword to specify that the <i>lc</i> material mixture number of the current crown have the same value <i>jmix</i> .  |
| UPTO          | keyword to attribute material mixture numbers of the current crown up to the <i>ic</i> one.   |
| <i>ic</i>     | number of the last crown in UPTO option. Its value must be greater than equal to the current crown number.  |
| HMIX          | keyword to specify the virtual isotopic mixture associated with each region inside the geometry. These virtual mixtures will be produced by homogenization in the EDI: module (see Section 3.7.1).  |
| CELL          | keyword to specify the location of the sub-geometry called <i>generating cells</i> in a Cartesian or hexagonal geometry.  |
| HCELL         | array of sub-geometry <b>character*12</b> names which will be superimposed upon the current Cartesian geometry. The same sub-geometry may appear in different positions within the global geometry if the material properties and dimensions are identical. The concept of sub-geometry is useful for the interface current method in a SYBIL calculation since the collision probability matrix associated with each sub-geometry is computed independently of its location in the geometry. In general, the neutron fluxes in identical sub-geometry located at different locations will be different even if they are associated with the same collision probability matrix. These sub-geometry names must be specified in the following order: <ol style="list-style-type: none"> <li>1. from surface X- to surface X+</li> <li>2. from surface Y- to surface Y+</li> <li>3. from surface Z- to surface Z+</li> </ol> |
| MERGE         | keyword to specify that some sub-geometries or regions must be merged.  |
| <i>imerge</i> | array of numbers that associate a global sub-geometry or region number with each sub-geometry or region. All the sub-geometries or regions with the same global number will be attributed the same flux.  |
| TURN          | keyword to specify that some sub-geometries must be rotated in space before being located at a specific position.   |
| HTURN         | array of <b>character*1</b> keywords to rotate conveniently each sub-geometry. The letters A to L are used as keywords to specify these rotation. For Cartesian geometries, the eight possible orientations are shown in Figure 17 while for hexagonal geometries the permitted orientations are shown in Figure 18. For 3-D cells, the same letters can be used to describe the rotation in the X – Y plane. However, an additional – sign can be glued to the 2-D rotation identifier to indicate reflection of the cell along the Z-axis (-A to -L).   |
| CLUSTER       | keyword to specify that pin (cylindrical) sub-geometry will be inserted in the geometry (see Figure 19).  |
| NAMPIN        | array of cylindrical sub-geometry <b>character*12</b> name representing a pin. This sub-geometry must be of type TUBE, TUBEX, TUBEY or TUBEZ.   |

**MIX-NAMES** keyword to specify character names to material mixtures. By default, the material mixtures are not named.

**NAMMIX** array of **character\*12** names for the material mixtures.



## 3.3.5 Double-heterogeneity

The structure (**descDH**) provides the possibility to define a stochastic mixture of cylindrical or spherical micro-structures that can be distributed inside *composite mixtures* of the current *macro-geometry*. A composite mixture is represented by a *material mixture index* with a value greater than *maxmix*, the maximum number of real mixtures. Each micro-structure can be composed of many micro-volumes.<sup>[52]</sup>

Table 21: Structure (**descDH**)

```
[ BIHET { TUBE | SPHE } nmistr nmilg
  (ns(i),i=1,nmistr)
  ((rs(i,j),j=1,ns(i)+1),i=1,nmistr)
  (milie(i),i=1,nmilg)
  (mixdil(i),i=1,nmilg)
  ( (fract(i,j),j=1,nmistr) ( [(mixgr(i,j,k),k=1,ns(j))],j=1,nmistr), i=1,nmilg ) ]
```

where

|               |  |
|---------------|--|
| BIHET         | keyword to specify that the current macro-geometry is containing composite mixtures.   |
| TUBE          | keyword to specify that the micro-structures are of a cylindrical geometry;  |
| SPHE          | keyword to specify that the micro-structures are of a spherical geometry.  |
| <i>nmistr</i> | maximum number of micro-structure types in the composite mixtures. Each type of micro-structure is characterized by its dimension and may have distinct volumetric concentrations in each of the macro-geometry volumes. All the micro-structures of a given type have the same nuclear properties in a given macro-volume. The micro-structures of a given type may have different nuclear properties within different macro-volumes. |
| <i>nmilg</i>  | number of composite mixtures. This is the number of material mixture indices of the macro-geometry with a value $>maxmix$ .  |
| <i>ns</i>     | array giving the number of sub-regions (tubes or spherical shells) in the micro-structures. Each type of micro-structures may contain a different number of micro-volumes.   |
| <i>rs</i>     | array giving the radius of the tubes or spherical shells making up the micro-structures. For each type of micro structure $i$ , we will have an initial radius of $rs(1, i) = 0.0$ .   |
| <i>milie</i>  | array giving the indices used to defined composite mixtures in the macro-geometry. These composite mixture indices must be $>maxmix$ .   |
| <i>mixdil</i> | array giving the mixture indices associated with the diluent in each composite mixtures of the macro-geometry. These values must be $\leq maxmix$ .  |
| <i>fract</i>  | array of volumetric concentration ( $V_G/V_R$ ) of each micro-structures (volume $V_G$ ) in a given region (volume $V_R$ ) of the macro-geometry.  |
| <i>mixgr</i>  | array giving the mixture index associated with each region of the micro-structures. Note that <i>mixgr</i> should be specified only for the regions of the micro-structure which have a concentration $fract > 0$ . These values must be $\leq maxmix$ .   |

Examples of geometry definitions can be found in Section 8.2.

### 3.3.6 Do-it-yourself geometries

A *do-it-yourself* geometry is an abstract representation of an assembly of arbitrary unit-cells defined in term of their probability of presence and of their probability to have a particular neighbor. Structure (**descSIJ**) is defined as

Table 22: Structure (**descSIJ**)

```
[ POURCE (pcinl(i),i=1,lp) ]
[ PROCEL ((pijcel(i,j),j=1,lp),i=1,lp) ]
```

where

**POURCE** keyword to specify that a *do-it-yourself* type geometry is to be defined, that is to say a geometry resembling the multicell geometry seen in APOLLO-1.<sup>[54]</sup> This option permits the interactions between different arbitrarily arranged cells in an infinite lattice to be treated. The cells are identified by the information following the keyword **CELL**. The user must ensure that the total number of regions appearing in all the cells must be less than *maxreg*.

*pcinl* array giving the proportion of each cell type in the lattice such that:

$$\left| \sum_{i=1}^{lp} pcinl(i) - 1 \right| < 10^{-5}$$

**PROCEL** keyword to specify that in a *do-it-yourself* type geometry rather than using a statistical arrangement of cells, a pre-calculated cell distribution is to be considered. If the **POURCE** structure is given without the **PROCEL** structure, a *statistical* approximation is used, as defined in Ref. 54.

*pijcel* array giving the pre-calculated probability for a neutron leaving a cell of type *i* to enter a cell of type *j* without crossing any other cell. We require:

$$|S(i)pcinl(i)pijcel(i, j) - S(j)pcinl(j)pijcel(j, i)| < 10^{-4}$$

where  $S(i)$  and  $S(j)$  are the exterior surfaces area of the cells of type *i* and *j* respectively.

Examples of geometry definitions can be found in Section 8.2.

### 3.4 The tracking modules

A tracking module is required to analyze a spatial domain (geometry) assuming a specific algorithm will be used for the collision probability or method of characteristics calculations. It performs zone numbering operations, volume and surface area calculations and generates the required integration lines for a geometry that was previously defined in the **GE0**: module. These operations are carried out differently depending on the solution algorithm used.

Many different operators are available for tracking in DRAGON. The **SYBILT**: module is used for 1-D geometries (either plane, cylindrical or spherical) and interface current tracking inside heterogeneous blocks. The **EXCELT**: module is used to perform full cell collision probability tracking with isotropic<sup>[21,22]</sup> or specular<sup>[26,29]</sup> surface current. The **NXT**: module is an extension of the **EXCELT**: module to more complex geometry including assemblies of clusters in two and three dimensions.<sup>[42]</sup> The **MCCGT**: module is an implementation of the open characteristics method of I. R. Suslov.<sup>[23,24]</sup> These are the transport tracking modules which can be used everywhere in the code where tracking information needs to be generated. The **SNT**: module is an implementation of the discrete ordinates (or  $S_N$ ) method in 1-D/2-D/3-D geometries. The module **BIVACT**: is used to perform a finite-element (diffusion or  $SP_n$ ) 1-D/2-D tracking which may be required for diffusion synthetic acceleration (DSA) or homogenization purposes.<sup>[57]</sup> The final module **TRIVAT**: is used to perform a finite-element 1-D/2-D/3-D tracking which may be required for DSA or homogenization purposes.<sup>[58]</sup>

None of these modules can analyze all of the geometry available in the code DRAGON. In general, the restrictions that apply to a given tracking module result directly from the approximation associated with this method. Moreover, in other instances, some geometries which would have had the same tracking file generated by two different method, such as tube geometry for the **SYBILT**: and **EXCELT**: module, have been made available only to one of these tracking module (module **SYBILT**: in this case).

The general information resulting from these tracking is stored in a **TRACKING** data structure. For the **EXCELT**: and **NXT**: modules, an additional sequential binary tracking file may be generated.

The global numbering of the zones in a geometry proceeds following an order of priorities given by:

- the different rings of a cylindrical or spherical region starting with the inner most after mesh splitting;
- for a cluster regions located in a ring, two different numbering schemes are possible. For the **EXCELT**: module, one first numbers the region inside the pin in the same way as for cylindrical regions and finishes by associating the next region number to the shell of the global geometry which contains this pin. If two cluster types are located in a given ring, they are classified according to increasing  $rpin$  and  $apin$  and then numbered in this order. Cluster overlapping annular region are numbered before considering the annular regions. For the **NXT**: module, each pin is numbered individually in a Cartesian region according to their ordered in the **CLUSTER** keywords and then the Cartesian regions are numbered sequentially. A description of the explicit numbering of regions and surfaces can be found in report IGE-260.<sup>[42]</sup>
- the zones in ascending order corresponding to the first axial component (normally  $X$ ) after mesh splitting;
- the zones in ascending order corresponding to the second axial component (normally  $Y$ ) after mesh splitting;
- the hexagonal zones corresponding to the order described in Figure 6 to Figure 11.
- the sub-geometry of type **CARCELX**, **CARCELY** and **CARCELZ** are numbered assuming that the third component corresponds to  $X$ ,  $Y$  and  $Z$  respectively.

We should also note that symmetry conditions implicitly force the grouping of certain calculation zones.

All the tracking operators of DRAGON share an identical general tracking data structure defined as

Table 23: Structure (**desctrack**)

```
[ EDIT iprint ]
[ TITL TITLE ]
[ MAXR maxreg ]
[ { NORE | RENO | REND } ]
```

with

|               |   |
|---------------|---|
| EDIT          | keyword used to modify the print level <i>iprint</i> .  |
| <i>iprint</i> | index used to control the printing of this operator. The amount of output produced by this tracking operators will vary substantially depending on the print level specified. For example, <ul style="list-style-type: none"> <li>• when <i>iprint</i>=0 no output is produced;</li> <li>• when <i>iprint</i>=1 a minimum amount of output is produced; the main geometry properties are printed (fixed default option);</li> <li>• when <i>iprint</i>≥2 In addition to the information printed when using <i>iprint</i>=1 the zone numbering (zones associated with a flux) is printed;</li> </ul> |
| TITL          | keyword which allows the run title to be set.   |
| <i>TITLE</i>  | the title associated with a DRAGON run. This title may contain up to 72 characters. The default when TITL is not specified is no title.   |
| MAXR          | keyword which permits the maximum number of regions to be considered during a DRAGON run to be specified.   |
| <i>maxreg</i> | maximum dimensions of the problem to be considered. The default value is set to the number of regions previously computed by the GEO: module. However this value is generally insufficient if symmetries or mesh-splitting are specified.   |
| NORE          | keyword to specify that the automatic normalization of the integration lines is deactivated.  |
| RENO          | keyword to specify the activation of the <i>direction-independent</i> normalization procedure of the integration lines. The normalization factors are <i>not</i> function of the subtracks directions. This option is only valid for modules NXT:, EXCELT: and SALT:. This is the default option for NXT: and SALT: modules.  |
| REND          | keyword to specify the activation of the <i>direction-dependent</i> normalization procedure of the integration lines. The normalization factors are function of the subtracks directions. This option is only valid for modules NXT:, EXCELT: and SALT:. This is the default option for EXCELT: module.   |

### 3.4.1 The SYBILT: tracking module

The geometries that can be treated by the module SYBILT: are

1. The homogeneous geometry HOMOGE.
2. The one-dimensional geometries SPHERE, TUBE and CAR1D.<sup>[55]</sup>
3. The two-dimensional geometries CAR2D and HEX including respectively CARCEL and HEXCEL sub-geometries as well as VIRTUAL sub-geometries.
4.  $S_{ij}$ -type two-dimensional non-standard geometries.<sup>[8]</sup>
5. The double heterogeneity option.<sup>[52]</sup>

The calling specification for this module is:

Table 24: Structure (SYBILT:)

```
TRKNAM := SYBILT: [ TRKNAM ] GEONAM :: (desctrack) (descsybil)
```

where

**TRKNAM**      **character\*12** name of the TRACKING data structure that will contain region volume and surface area vectors in addition to region identification pointers and other tracking information. If *TRKNAM* also appears on the RHS, the previous tracking parameters will be applied by default on the current geometry.

**GEONAM**      **character\*12** name of the GEOMETRY data structure.

**(desctrack)**    structure describing the general tracking data (see Section 3.4)

**(descsybil)**    structure describing the transport tracking data specific to SYBILT:.

The SYBILT: specific tracking data in **(descsybil)** is defined as

Table 25: Structure (descsybil)

```
[ MAXJ maxcur ] [ MAXZ maxint ]
[ HALT ]
[ QUA1 iqua1 ] [ QUA2 iqua2 nsegment ] [ { EQW | GAUS } ]
[ { ROTH | ROT+ | DPO0 | DPO1 } ]
[ { WIGN | ASKE | SANC } ] [ LIGN ] [ RECT ]
[ EPSJ epsj ]
[ [ QUAB iquab ] [ { SAPO | HEBE | SLSI [ frtm ] } ] ]
;
```

where

**MAXJ**            keyword to specify the maximum number of interface currents surrounding the blocks in the calculations.

|                 |   |
|-----------------|---|
| <i>maxcur</i>   | the maximum number of interface currents surrounding the blocks. The default value is $maxcur = \max(18, 4 \times maxreg)$ for the SYBILT: module.  |
| MAXZ            | keyword to specify the maximum amount of memory required to store the integration lines. An insufficiently large value can lead to an execution failure (core dump).  |
| <i>maxint</i>   | the maximum amount of memory required to store the integration lines. The default value is $maxint = 10000$ .   |
| HALT            | keyword to specify that the program is to be stopped at the end of the geometry calculations. This option permits the geometry inputs to be checked, the number of blocks and interface currents to be calculated, and a conservative estimate of the memory required for storing the tracks to be made for mixed geometries.   |
| QUA1            | keyword to specify the one-dimensional integration parameters.  |
| <i>iqua1</i>    | number of basis points for the angular integration of the blocks in a one-dimensional geometry. This parameter is not used for CAR1D geometries. If a Gauss-Legendre or Gauss-Jacobi quadrature is used, the values of <i>iqua1</i> allowed are: 1 to 20, 24, 28, 32 or 64. The default value is $iqua1 = 5$ .  |
| QUA2            | keyword to specify the two-dimensional integration parameters.  |
| <i>iqua2</i>    | number of basis points for the angular integration of the blocks in a two-dimensional geometry appearing during assembly calculations. If a Gauss-Legendre or Gauss-Jacobi formula is used the values allowed for <i>iqua2</i> are: 1 to 20, 24, 28, 32 or 64. The default value is $iqua2 = 3$ and represents the number of angles in $(0, \pi/4)$ for Cartesian geometries and $(0, \pi/6)$ for hexagonal geometries. |
| <i>nsegment</i> | number of basis points for the spatial integration of the blocks in a two-dimensional geometry appearing during assembly calculations. The values of <i>nsegment</i> allowed are: 1 to 10. The default value is $nsegment = 3$ .  |
| EQW             | keyword to specify the use of equal-weight quadrature.  |
| GAUS            | keyword to specify the use of the Gauss-Legendre or the Gauss-Jacobi quadrature. This is the default option.  |
| ROTH            | keyword to specify that the isotropic ( $DP_0$ ) components of the inter-cell current is used with the incoming current being averaged over all the faces surrounding a cell. The global collision matrix is calculated in an annular model. Only used when 2-d assembly of cells are considered.   |
| ROT+            | keyword to specify that the isotropic ( $DP_0$ ) components of the inter-cell current is used. The global collision matrix is calculated in an annular model. Only used when 2-d assembly of cells are considered.  |
| DP00            | keyword to specify that the isotropic ( $DP_0$ ) components of the inter-cell current is used. The global collision matrix are computed explicitly. Only used when 2-d assembly of cells are considered.  |
| DP01            | keyword to specify that the linearly anisotropic ( $DP_1$ ) components of the inter-cell current are used. This hypothesis implies 12 currents per cell in a cartesian geometry and 18 currents per cell for an hexagonal geometry. Linearly anisotropic reflection is used. Only used when 2-d assembly of cells are considered.   |
| WIGN            | keyword to specify the use of a Wigner cylinderization which preserves the volume of the external crown. This applies only in cases where the external surface is annular using the ROTH or ROT+ options. Only used when 2-d assembly of cells are considered. Note that an assembly of rectangular cells having unequal volumes cannot use a Wigner cylinderization.   |

|              |  |
|--------------|--|
| ASKE         | keyword to specify the use of an <i>Askew</i> cylinderization which preserves both the external surface of the cells and the material balance of the external crown (by a modification of its concentration). This applies only in cases where the external surface is annular using the ROTH or ROT+ options. Only used when 2-d assembly of cells are considered. Note that an assembly of rectangular cells having unequal volumes can use an <i>Askew</i> cylinderization.   |
| SANC         | keyword to specify the use of a <i>Sanchez</i> cylinderization. This model uses a <i>Wigner</i> cylinderization for computing the collision $P_{ij}$ and leakage $P_{iS}$ probabilities. However, the reciprocity and conservation relations used to compute the incoming $P_{Sj}$ and transmission $P_{SS}$ probabilities are defined in the rectangular cell (with the exact surface). <sup>[56]</sup> This applies where the external surface is annular using the ROTH or ROT+ options. Only used when 2-d assembly of cells are considered. Note that an assembly of rectangular cells having unequal volumes can use a <i>Sanchez</i> cylinderization. This is the default option. |
| LIGN         | keyword to specify that all the integration lines are to be printed. This option should only be used when absolutely necessary because it generates a rather large amount of output. Only used when 2-d assembly of cells are considered.  |
| RECT         | keyword to specify that square cells are to be treated as if they were rectangular cells, with the inherent loss in performance that this entails. This option is of purely academic interest.   |
| EPSJ         | keyword to specify the stopping criterion for the flux-current iterations of the interface current method in case the ARM keyword is set in the ASM: module or in a resonance self-shielding module (SHI:, USS:, etc.).  |
| <i>epsj</i>  | the stopping criterion value. The default value is $epsj = 0.5 \times 10^{-5}$ .   |
| QUAB         | keyword to specify the number of basis point for the numerical integration of each microstructure in cases involving double heterogeneity (Bihet).   |
| <i>iquab</i> | the number of basis point for the numerical integration of the collision probabilities in the micro-volumes using the Gauss-Jacobi formula. The values permitted are: 1 to 20, 24, 28, 32 or 64. The default value is $iquab=5$ . If <i>iquab</i> is negative, its absolute value will be used in the She-Liu-Shi approach to determine the split level in the tracking used to compute the probability collisions.  |
| SAP0         | use the Sanchez-Pomraning double-heterogeneity model. <sup>[51]</sup>  |
| HEBE         | use the Hebert double-heterogeneity model (default option). <sup>[52]</sup>  |
| SLSI         | use the She-Liu-Shi double-heterogeneity model without shadow effect. <sup>[53]</sup>  |
| <i>frtm</i>  | the minimum microstructure volume fraction used to compute the size of the equivalent cylinder in She-Liu-Shi approach. The default value is $frtm = 0.05$ .   |

## 3.4.2 The EXCELT: tracking module

The calling specification for this module is:

Table 26: Structure (**EXCELT:**)

```
TRKNAM [ TRKFIL ] := EXCELT: [ TRKNAM ] [ TRKFIL ] GEONAM :: (desctrack) (descexcel)
```

where

|                      |   |
|----------------------|---|
| <i>TRKNAM</i>        | <b>character*12</b> name of the TRACKING data structure that will contain region volume and surface area vectors in addition to region identification pointers and other tracking information. If <i>TRKNAM</i> also appears on the RHS, the previous tracking parameters will be applied by default on the current geometry.   |
| <i>TRKFIL</i>        | <b>character*12</b> name of the sequential binary tracking file used to store the tracks lengths. If <i>TRKFIL</i> does not appear, the keyword <b>XCLL</b> is set automatically. If the user wants to use a tracking file, <i>TRKFIL</i> is required for the <b>EXCELT:</b> module, either on the LHS, on the RHS or on both sides. In the case where <i>TRKFIL</i> appears on both LHS and RHS, the existing tracking file is modified by the module while if <i>TRKFIL</i> appears only on the RHS, the existing tracking file is read but not modified. |
| <i>GEONAM</i>        | <b>character*12</b> name of the GEOMETRY data structure.  |
| ( <b>desctrack</b> ) | structure describing the general tracking data (see Section 3.4)  |
| ( <b>descexcel</b> ) | structure describing the transport tracking data specific to <b>EXCELT:</b> .   |

The **EXCELT:** specific tracking data in (**descexcel**) is defined as

Table 27: Structure (**descexcel**)

```
[ ANIS nanis ]
[ { ONEG | ALLG | XCLL } ]
[ { TREG | TMER } ]
[ { PISO | PSPC [ CUT pcut ] } ]
[ [ QUAB iquab ] [ { SAPO | HEBE | SLSI [ frtm ] } ] ]
[ { PRIX | PRIY | PRIZ } denspr ]
[ { LCMD | OPP1 | OGAU | GAUS | CACA | CACB } [ nmu ] ]
[ TRAK { TISO nanl [ nanl_z ] dens [ dens_z ] [ CORN pcorn ] [ SYMM isymm | NOSY ] |
TSPC [ MEDI ] nanl dens | HALT } ]
;
```

where

|              |   |
|--------------|---|
| <b>ANIS</b>  | keyword to specify the order of scattering anisotropy.  |
| <i>nanis</i> | order of anisotropy in transport calculation. A default value of 1 represents isotropic (or transport-corrected) scattering while a value of 2 correspond to linearly anisotropic |



scattering. When anisotropic scattering is considered, user should pay attention to the following points:

- the usage of `DIAG`, `SYME`, `SSYM` keywords in the definition of the geometry is forbidden. Indeed, in `EXCELT:/NXT`: tracking procedures, the geometry is “unfolded” according to these symmetries : this is incompatible with the integration of the anisotropic moments of the flux;
- the angular quadratures should be selected paying attention to the restrictions mentioned in this manual in order to ensure the particle conservation.

|                    |   |
|--------------------|---|
| <code>ONEG</code>  | keyword to specify that the tracking is read before computing each group-dependent collision probability or algebraic collapsing matrix (default value if <code>TRKFIL</code> is set). The tracking file is read in each energy group if the method of characteristics (MOC) is used.   |
| <code>ALLG</code>  | keyword to specify that the tracking is read once and the collision probability or algebraic collapsing matrices are computed in many energy groups. The tracking file is read once if the method of characteristics (MOC) is used.   |
| <code>XCLL</code>  | keyword to specify that the tracking is computed <i>on-demand</i> (it is not stored on a file) and the collision probability matrices are computed in many energy groups. The tracking file <code>TRKFIL</code> should <i>not</i> be provided (default value if <code>TRKFIL</code> is not set).  |
| <code>TREG</code>  | keyword to specify that the normalization procedure of the integration lines activated by keywords <code>RENO</code> or <code>REND</code> in Sect. 3.4 is to be performed with respect of the fine volumes as specified in the <code>KEYFLX</code> record of the tracking object. This is the default option.   |
| <code>TMER</code>  | keyword to specify that the normalization procedure of the integration lines activated by keywords <code>RENO</code> or <code>REND</code> in Sect. 3.4 is to be performed with respect of the <i>merged volumes</i> as specified in the <code>KEYMRG</code> record of the tracking object.  |
| <code>PISO</code>  | keyword to specify that a collision probability calculation with isotropic reflection boundary conditions is required. It is the default option if a <code>TISO</code> type integration is chosen. To obtain accurate transmission probabilities for the isotropic case it is recommended that the normalization options in the <code>ASM</code> : module be used.  |
| <code>PSPC</code>  | keyword to specify that a collision probability calculation with specular reflection boundary conditions required; this is the default option if a <code>TSPC</code> type integration is chosen. This calculation is only possible if the file was initially constructed using the <code>TSPC</code> option.  |
| <code>CUT</code>   | keyword to specify the input of cutting parameters for the specular integration.  |
| <code>pcut</code>  | real value representing the maximum error allowed on the exponential function used for specular collision probability calculations. Tracks will be cut at a length such that the error in the probabilities resulting from this reduced track will be of the order of <code>pcut</code> . By default, there is no cutting of the tracks and <code>pcut</code> =0.0. If this option is used in an entirely reflected case, it is preferable to use the <code>NORM</code> command in the <code>ASM</code> : module. |
| <code>QUAB</code>  | keyword to specify the number of basis point for the numerical integration of each micro-structure in cases involving double heterogeneity (Bihet).   |
| <code>iquab</code> | the number of basis point for the numerical integration of the collision probabilities in the micro-volumes using the Gauss-Jacobi formula. The values permitted are: 1 to 20, 24, 28, 32 or 64. The default value is <code>iquab</code> =5. If <code>iquab</code> is negative, its absolute value will be used in the She-Liu-Shi approach to determine the split level in the tracking used to compute the probability collisions.  |

|               |   |
|---------------|---|
| SAPO          | use the Sanchez-Pomraning double-heterogeneity model. <sup>[51]</sup>   |
| HEBE          | use the Hebert double-heterogeneity model (default option). <sup>[52]</sup>   |
| SLSI          | use the She-Liu-Shi double-heterogeneity model without shadow effect. <sup>[53]</sup>   |
| <i>frtm</i>   | the minimum microstructure volume fraction used to compute the size of the equivalent cylinder in She-Liu-Shi approach. The default value is $frtm = 0.05$ .  |
| PRIX          | keyword to specify that a prismatic tracking is considered for a 3D geometry invariant along the $x$ - axis. In this case, the 3D geometry is projected in the $y - z$ plane and a 2D tracking on the projected geometry is performed. This capability is limited to the non-cyclic method of characteristics solver for the time being and a subsequent call to <code>MCCGT</code> : is mandatory. |
| PRIY          | keyword to specify that a prismatic tracking is considered for a 3D geometry invariant along the $y$ - axis. In this case, the 3D geometry is projected in the $z - x$ plane and a 2D tracking on the projected geometry is performed. This capability is limited to the method of characteristics solver for the time being and a subsequent call to <code>MCCGT</code> : is mandatory.            |
| PRIZ          | keyword to specify that a prismatic tracking is considered for a 3D geometry invariant along the $z$ - axis. In this case, the 3D geometry is projected in the $x - y$ plane and a 2D tracking on the projected geometry is performed. This capability is limited to the method of characteristics solver for the time being and a subsequent call to <code>MCCGT</code> : is mandatory.            |
| <i>denspr</i> | real value representing the linear track density (in $\text{cm}^{-1}$ ) to be used for the inline construction of 3D tracks from 2D tracking when a prismatic tracking is considered.   |
| LCMD          | keyword to specify that optimized (McDaniel-type) polar integration angles are to be selected for the polar quadrature when a prismatic tracking is considered. <sup>[48]</sup> This is the default option. The conservation is ensured only for isotropic scattering.  |
| OPP1          | keyword to specify that $P_1$ constrained optimized (McDaniel-type) polar integration angles are to be selected for the polar quadrature when a prismatic tracking is considered. <sup>[49]</sup> The conservation is ensured only for isotropic and linearly anisotropic scattering.   |
| OGAU          | keyword to specify that Optimized Gauss polar integration angles are to be selected for the method of characteristics. <sup>[48, 49]</sup> The conservation is ensured up to $P_{nm\mu-1}$ scattering.  |
| GAUS          | keyword to specify that Gauss-Legendre polar integration angles are to be selected for the polar quadrature when a prismatic tracking is considered. The conservation is ensured up to $P_{nm\mu-1}$ scattering.  |
| CACA          | keyword to specify that CACTUS type equal weight polar integration angles are to be selected for the polar quadrature when a prismatic tracking is considered. <sup>[50]</sup> The conservation is ensured only for isotropic scattering.   |
| CACB          | keyword to specify that CACTUS type uniformly distributed integration polar angles are to be selected for the polar quadrature when a prismatic tracking is considered. <sup>[50]</sup> The conservation is ensured only for isotropic scattering.  |
| <i>nmu</i>    | user-defined number of polar angles. By default, a value consistent with <i>nanql</i> is computed by the code. For <code>LCMD</code> , <code>OPP1</code> , <code>OGAU</code> quadratures, <i>nmu</i> is limited to 2, 3 or 4.   |
| TRAK          | keyword to specify the tracking parameters to be used.  |
| TISO          | keyword to specify that isotropic tracking parameters will be supplied. This is the default tracking option for cluster geometries.   |

|                          |   |
|--------------------------|---|
| TSPC                     | keyword to specify that specular tracking parameters will be supplied.  |
| MEDI                     | keyword to specify that instead of selecting the angles located at the end of each angular interval, the angles located in the middle of these intervals are selected. This is particularly useful if one wants to avoid tracking angles that are parallel to the $X$ – or $Y$ –axis as its is the case when the external region of a CARCEL geometry is voided.  |
| <i>nangl</i>             | angular quadrature parameter. For applications involving 3–D cells, the choices are <i>nangl</i> =2, 4, 8, 10, 12, 14 or 16; these angular quadratures $EQ_n$ present a rotational symmetry about the three cartesian axes. For 2–D isotropic applications, any value of <i>nangl</i> $\geq 2$ may be used; equidistant angles will be selected. For 2–D specular applications the input value must be of the form $p + 1$ where $p$ is a prime number (for example $p=7, 11, \text{etc.}$ ); the choice of <i>nangl</i> = 8, 12, 14, 18, 20, 24, or 30 are allowed. For cluster type geometries the default value is <i>nangl</i> =10 for isotropic cases and <i>nangl</i> =12 for specular cases. |
| <i>nangl<sub>z</sub></i> | angular quadrature parameter in the axial $Z$ direction. Used only with <i>HEXZ</i> and <i>HEXCELZ</i> geometries.  |
| <i>dens</i>              | real value representing the density of the integration lines (in $\text{cm}^{-1}$ for 2–D cases and $\text{cm}^{-2}$ for 3–D cases). This choice of density along the plan perpendicular to each angle depends on the geometry of the cell to be analyzed. If there are zones of very small volume, a high line density is essential. This value will be readjusted by EXCELT:. In the case of the analysis of a cluster type geometry the default value of this parameter is $5/r_m$ where $r_m$ is the minimum radius of the pins or the minimum thickness of an annular ring in the geometry. If the selected value of <i>dens</i> is too small, some volumes or surfaces may not be tracked.    |
| <i>dens<sub>z</sub></i>  | real value representing the density of the integration lines in the axial $Z$ direction. Used only with <i>HEXZ</i> and <i>HEXCELZ</i> geometries.  |
| CORN                     | keyword to specify that the input of the parameters used to treat the corners for the isotropic integration.  |
| <i>pcorn</i>             | maximum distance (cm) between a line and the intersection of $n \geq 2$ external surfaces where track redistribution will take place. Track redistribution will take place if a line comes close to the intersection of $n \geq 2$ external surfaces. In this case the line will be replicated $n$ times, each of these lines being associated with a different external surface, while its weight is reduced by a factor of $1/n$ . This allows for a better distribution of tracks which are relatively close to $n$ external surfaces. By default, there is no treatment of the corners and <i>pcorn</i> =0.0.   |
| SYMM                     | keyword to specify that the geometry has a rotation symmetry.   |
| <i>isymm</i>             | integer value describing the rotation symmetry of the geometry. The fixed default of this parameter is 1.   |
| NOSY                     | EXCELT: automatically try to take into account geometric symmetries in order to reduce the number of tracks and the CPU time. The NOSY keyword desactivates this automatic capability.  |
| HALT                     | keyword to specify that the program is to be stopped after the analysis of the geometry, without the explicit tracking being performed.   |

## 3.4.3 The NXT: tracking module

The calling specification for this module is:

Table 28: Structure (NXT:)

```
[ TRKFIL ] TRKNAM := NXT: [ TRKNAM ] [ GEONAM ] :: (desctrack) (descnxt)
```

where

|                      |   |
|----------------------|---|
| <i>TRKNAM</i>        | <b>character*12</b> name of the TRACKING data structure that will contain region volume and surface area vectors in addition to region identification pointers and other tracking information. If <i>TRKNAM</i> also appears on the RHS, the previous tracking parameters will be applied by default on the current geometry. |
| <i>TRKFIL</i>        | <b>character*12</b> name of the sequential binary tracking file used to store the tracks lengths. If <i>TRKFIL</i> does not appear, the keyword <b>XCLL</b> is set automatically. If the user wants to use a tracking file, <i>TRKFIL</i> is required.  |
| <i>GEONAM</i>        | <b>character*12</b> name of the GEOMETRY data structure.  |
| ( <b>desctrack</b> ) | structure describing the general tracking data (see Section 3.4)  |
| ( <b>descnxt</b> )   | structure describing the transport tracking data specific to <b>NXT</b> ..  |

The **NXT**: specific tracking data in (**descnxt**) is defined as

Table 29: Structure (**descnxt**)

```
[ ANIS nanis ]
[ { ONEG | ALLG | XCLL } ]
[ [ QUAB iquab ] [ { SAPO | HEBE | SLSI [ frtm ] } ] ]
[ { PISO | PSPC [ CUT pcut ] } ]
[ { SYMM isymm | NOSY } ]
[ { GAUS | CACA | CACB | LCMD | OPP1 | OGAU } [ nmu ] ]
{ TISO [ { EQW | GAUS | PNTN | SMS | LSN | QRN } ] nanagl dens [ CORN pcorn ]
  | TSPC [ { EQW | MEDI | EQW2 } ] nanagl dens }
[ { NOTR | MC } ]
[ NBSLIN nbslin ]
[ LONG ]
[ PRIZ denspr ]
;
```

where

|              |   |
|--------------|---|
| <b>ANIS</b>  | keyword to specify the order of scattering anisotropy.  |
| <i>nanis</i> | order of anisotropy in transport calculation. A default value of 1 represents isotropic (or transport-corrected) scattering while a value of 2 correspond to linearly anisotropic |

scattering. When anisotropic scattering is considered, user should pay attention to the following points:

- the usage of `DIAG`, `SYME`, `SSYM` keywords in the definition of the geometry is forbidden. Indeed, in `EXCELT:/NXT`: tracking procedures, the geometry is “unfolded” according to these symmetries : this is incompatible with the integration of the anisotropic moments of the flux;
- an angular dependent normalization of the track lengths should be requested in the tracking procedure (`REND` keyword) in order to ensure the particle conservation;
- the angular quadratures should be selected paying attention to the restrictions mentioned in this manual in order to ensure the particle conservation.

|                    |   |
|--------------------|---|
| <code>ONEG</code>  | keyword to specify that the tracking is read before computing each group-dependent collision probability or algebraic collapsing matrix (default value if <code>TRKFIL</code> is set). The tracking file is read in each energy group if the method of characteristics (MOC) is used.   |
| <code>ALLG</code>  | keyword to specify that the tracking is read once and the collision probability or algebraic collapsing matrices are computed in many energy groups. The tracking file is read once if the method of characteristics (MOC) is used.   |
| <code>XCLL</code>  | keyword to specify that the tracking is computed <i>on-demand</i> (it is not stored on a file) and the collision probability matrices are computed in many energy groups. The tracking file <code>TRKFIL</code> should <i>not</i> be provided (default value if <code>TRKFIL</code> is not set).  |
| <code>QUAB</code>  | keyword to specify the number of basis point for the numerical integration of each micro-structure in cases involving double heterogeneity (Bihet).   |
| <code>iquab</code> | the number of basis point for the numerical integration of the collision probabilities in the micro-volumes using the Gauss-Jacobi formula. The values permitted are: 1 to 20, 24, 28, 32 or 64. The default value is <code>iquab</code> = 5. If <code>iquab</code> is negative, its absolute value will be used in the She-Liu-Shi approach to determine the split level in the tracking used to compute the probability collisions. |
| <code>SAPO</code>  | use the Sanchez-Pomraning double-heterogeneity model. <sup>[51]</sup>   |
| <code>HEBE</code>  | use the Hebert double-heterogeneity model (default option). <sup>[52]</sup>   |
| <code>SLSI</code>  | use the She-Liu-Shi double-heterogeneity model without shadow effect. <sup>[53]</sup>   |
| <code>frtm</code>  | the minimum microstructure volume fraction used to compute the size of the equivalent cylinder in She-Liu-Shi approach. The default value is <code>frtm</code> = 0.05.  |
| <code>PISO</code>  | keyword to specify that a collision probability calculation with isotropic reflection boundary conditions is required. It is the default option if a <code>TISO</code> type integration is chosen. To obtain accurate transmission probabilities for the isotropic case it is recommended that the normalization options in the <code>ASM</code> : module be used.  |
| <code>PSPC</code>  | keyword to specify that a collision probability calculation with mirror like reflection or periodic boundary conditions is required; this is the default option if a <code>TSPC</code> type integration is chosen. This calculation is only possible if the file was initially constructed using the <code>TSPC</code> option.  |
| <code>CUT</code>   | keyword to specify the input of cutting parameters for the specular collision probability of characteristic integration.  |

|              |   |
|--------------|---|
| <i>pcut</i>  | real value representing the maximum error allowed on the exponential function used for specular collision probability calculations. Tracks will be cut at a length such that the error in the probabilities resulting from this reduced track will be of the order of <i>pcut</i> . By default, the tracks are extended to infinity and <i>pcut</i> = 0.0. If this option is used in an entirely reflected case, it is recommended to use the <b>NORM</b> command in the <b>ASM:</b> module.  |
| <b>SYMM</b>  | keyword to specify the level to which the tracking will respect the symmetry of the geometry.   |
| <i>isymm</i> | level to which the tracking will respect the symmetry of the geometry. For 2-D and 3-D Cartesian geometries it must take the form $isymm=2S_x + 4S_y + 16S_z$ where <ul style="list-style-type: none"> <li>• <math>S_x = 1</math> if the <i>X</i> symmetry is to be considered and <math>S_x = 0</math> otherwise.</li> <li>• <math>S_y = 1</math> if the <i>Y</i> symmetry is to be considered and <math>S_y = 0</math> otherwise.</li> <li>• <math>S_z = 1</math> if the <i>Z</i> symmetry is to be considered and <math>S_z = 0</math> otherwise.</li> </ul> |
| <b>NOSY</b>  | keyword to specify the full tracking will take place irrespective of the symmetry of the geometry. This is equivalent to specifying $isymm=0$ .   |
| <b>GAUS</b>  | keyword to specify that Gauss-Legendre polar integration angles are to be selected for the polar quadrature when a prismatic tracking is considered. The conservation is ensured up to $P_{nm\mu-1}$ scattering.  |
| <b>CACA</b>  | keyword to specify that CACTUS type equal weight polar integration angles are to be selected for the polar quadrature when a prismatic tracking is considered. <sup>[50]</sup> The conservation is ensured only for isotropic scattering.   |
| <b>CACB</b>  | keyword to specify that CACTUS type uniformly distributed integration polar angles are to be selected for the polar quadrature when a prismatic tracking is considered. <sup>[50]</sup> The conservation is ensured only for isotropic scattering.  |
| <b>LCMD</b>  | keyword to specify that optimized (McDaniel-type) polar integration angles are to be selected for the polar quadrature when a prismatic tracking is considered. <sup>[48]</sup> This is the default option. The conservation is ensured only for isotropic scattering.  |
| <b>OPP1</b>  | keyword to specify that $P_1$ constrained optimized (McDaniel-type) polar integration angles are to be selected for the polar quadrature when a prismatic tracking is considered. <sup>[49]</sup> The conservation is ensured only for isotropic and linearly anisotropic scattering.   |
| <b>OGAU</b>  | keyword to specify that Optimized Gauss polar integration angles are to be selected for the method of characteristics. <sup>[48,49]</sup> The conservation is ensured up to $P_{nm\mu-1}$ scattering.   |
| <i>nm\mu</i> | user-defined number of polar angles. By default, a value consistent with <i>nangl</i> is computed by the code. For <b>LCMD</b> , <b>OPP1</b> , <b>OGAU</b> quadratures, <i>nm\mu</i> is limited to 2, 3 or 4.   |
| <b>TISO</b>  | keyword to specify that isotropic tracking parameters will be supplied. This is the default tracking option for cluster geometries.   |
| <b>TSPC</b>  | keyword to specify that specular tracking parameters will be supplied.  |
| <b>EQW</b>   | keyword to specify the use of equal weight quadrature. <sup>[43]</sup> The conservation is ensured up to $P_{nangl/2}$ scattering.  |
| <b>GAUS</b>  | (after <b>TISO</b> keyword) keyword to specify the use of the Gauss-Legendre quadrature. This option is valid only if a hexagonal geometry is considered.   |
| <b>PNTN</b>  | keyword to specify that Legendre-Techbychev quadrature will be selected. <sup>[44]</sup> The conservation is ensured only for isotropic and linearly anisotropic scattering.  |

|              |  |
|--------------|--|
| SMS          | keyword to specify that Legendre-trapezoidal quadrature will be selected. <sup>[45]</sup> The conservation is ensured up to $P_{nangl-1}$ scattering.  |
| LSN          | keyword to specify the use of the $\mu_1$ -optimized level-symmetric quadrature. The conservation is ensured up to $P_{nangl/2}$ scattering.   |
| QRN          | keyword to specify the use of the quadrupole range (QR) quadrature. <sup>[34]</sup>  |
| MEDI         | keyword to specify the use of a median angle quadrature in TSPC cases. Instead of selecting the angles located at the end of each angular interval, the angles located in the middle of these intervals are selected. This is particularly useful if one wants to avoid tracking angles that are parallel to the $X$ - or $Y$ -axis as its is the case when the external region of a CARCEL geometry is voided.  |
| EQW2         | keyword to eliminate angles $\phi = 0$ and $\phi = \pi/2$ from the EQW quadrature in TSPC cases.   |
| <i>nangl</i> | angular quadrature parameter. For a 3-D EQW option, the choices are $nangl = 2, 4, 8, 10, 12, 14$ or $16$ . For a 3-D PNTN or SMS option, <i>nangl</i> is an even number smaller than $46$ . <sup>[42]</sup> For 2-D isotropic applications, any value of <i>nangl</i> may be used, equidistant angles will be selected.<br><br>For 2-D specular applications the input value must be of the form $p + 1$ where $p$ is a prime number, as proposed in Ref. 28. In this case, the choice of $nangl = 2, 8, 12, 14, 18, 20, 24,$ or $30$ are allowed. For a rectangular Cartesian domain of size $X \times Y$ , the azimuthal angles in $(0, \pi/2)$ interval are obtained from formula $\phi_k = \begin{cases} \arctan\left(\frac{kY}{(p-k)X}\right), & k = 0, 1, 2, \dots, p & \text{if EQW (default)} \\ \arctan\left(\frac{kY}{(2p+2-k)X}\right), & k = 1, 3, 5, \dots, 2p+1 & \text{if MEDI} \\ \arctan\left(\frac{kY}{(p+2-k)X}\right), & k = 1, 2, 3, \dots, p+1 & \text{if EQW2.} \end{cases}$ |
| <i>dens</i>  | real value representing the density of the integration lines (in $\text{cm}^{-1}$ for 2-D Cartesian cases and 3-D hexagonal cases and $\text{cm}^{-2}$ for 3-D cases Cartesian cases). This choice of density along the plan perpendicular to each angle depends on the geometry of the cell to be analyzed. If there are zones of very small volume, a high line density is essential. This value will be readjusted by NXT:.   |
| CORN         | keyword to specify that the input of the parameters used to treat the corners for the isotropic integration.   |
| <i>pcorn</i> | maximum distance (cm) between a line and the intersection of $n \geq 2$ external surfaces where track redistributing will take place. Track redistribution will take place if a line comes close to the intersection of $n \geq 2$ external surfaces. In this case the line will be replicated $n$ times, each of these lines being associated with a different external surface, while its weight is reduced by a factor of $1/n$ . This allows for a better distribution of tracks which are relatively close to $n$ external surfaces. By default, there is no treatment of the corners and $pcorn = 0.0$ .   |
| NOTR         | keyword to specify that the geometry will not be tracked. This is useful for 2-D geometries to generate a tracking data structure that can be used by the PSP: module (see Section 3.31). One can then verify visually if the geometry is adequate before the tracking process as such is undertaken.  |
| MC           | keyword to specify that the geometry will not be tracked and that object <i>TRKNAM</i> will be used with the Monte-Carlo method. This option is similar to NOTR with additional information being added into <i>TRKNAM</i> .   |
| NBSLIN       | keyword to set the maximum number of segments in a single tracking line.   |

|               |  |
|---------------|--|
| <i>nbsl</i>   | integer value representing the maximum number of segments in a single tracking line. The default value is $nbsl = 100000$ .  |
| LONG          | keyword to specify that a “long” tracking file will be generated. This option is required if the tracking file is to be used by the TLM: module (see Section 3.14).  |
| PRIZ          | keyword to specify that a prismatic tracking is considered for a 3D geometry invariant along the $z$ - axis. In this case, the 3D geometry is projected in the $x - y$ plane and a 2D tracking on the projected geometry is performed. This capability is limited to the non-cyclic method of characteristics solver for the time being and a subsequent call to MCGT: is mandatory. |
| <i>denspr</i> | real value representing the linear track density (in $\text{cm}^{-1}$ ) to be used for the inline construction of 3D tracks from 2D tracking when a prismatic tracking is considered.  |



## 3.4.4 The MCCGT: tracking module

This module *must* follow a call to module EXCELT: or NXT:. Its calling specification is:

Table 30: Structure (MCCGT:)

```
TRKNAM := MCCGT: TRKNAM TRKFIL [ GEONAM ] :: (descmccg)
```

where

- TRKNAM**      **character\*12** name of the TRACKING data structure that will contain region volume and surface area vectors in addition to region identification pointers and other tracking information. It is provided by EXCELT: or NXT: operator and modified by MCCGT: operator.
- TRKFIL**      **character\*12** name of the sequential binary tracking file used to store the tracks lengths. This file is provided by EXCELT: or NXT: operator and used without modification by MCCGT: operator.
- GEONAM**      **character\*12** name of the optional GEOMETRY data structure. This structure is only required to recover double-heterogeneity data.
- (descmccg)**    structure describing the transport tracking data specific to MCCGT:.

The MCCGT: specific tracking data in **(descmccg)** is defined as

Table 31: Structure (descmccg)

```
[ EDIT iprint ]
[ { LCMD | OPP1 | OGAU | GAUS | DGAU | CACA | CACB } [ nmu ] ]
{ DIFC [ { NONE | DIAG | FULL | ILUO } ] [ TMT ] [ LEXA ]
  |
  [ [ AAC iaca [ { NONE | DIAG | FULL | ILUO } ] [ TMT ] ] [ SCR iscr ] [ LEXA ] ]
  [ KRYL ikryl ]
  [ MCU imcu ]
  [ HDD xhdd ]
  [ { SC | LDC } ]
  [ LEXF ]
  [ STIS istis ]
}
[ MAXI nmaxi ]
[ EPSI xepsi ]
[ ADJ ]
;
```

where

- EDIT**            keyword used to modify the print level *iprint*.
- iprint***          index used to control the printing in this operator.

|              |   |
|--------------|---|
| LCMD         | keyword to specify that optimized (McDaniel-type) polar integration angles are to be selected for the method of characteristics. <sup>[48]</sup> The conservation is ensured only for isotropic scattering.   |
| OPP1         | keyword to specify that $P_1$ constrained optimized (McDaniel-type) polar integration angles are to be selected for the method of characteristics. <sup>[49]</sup> The conservation is ensured only for isotropic and linearly anisotropic scattering.  |
| OGAU         | keyword to specify that Optimized Gauss polar integration angles are to be selected for the method of characteristics. <sup>[48, 49]</sup> The conservation is ensured up to $P_{nmu-1}$ scattering.  |
| GAUS         | keyword to specify that the polar integration angles are to be selected as a single Gauss-Legendre quadrature for the method of characteristics in interval $(-\pi/2, \pi/2)$ . The conservation is ensured up to $P_{nmu-1}$ scattering. This is the default option.                                       |
| DGAU         | keyword to specify that the polar integration angles are to be selected as a double Gauss-Legendre quadrature for the method of characteristics in intervals $(-\pi/2, 0)$ and $(0, \pi/2)$ . The conservation is ensured up to $P_{nmu-1}$ scattering.   |
| CACA         | keyword to specify that CACTUS type equal weight polar integration angles are to be selected for the method of characteristics. <sup>[50]</sup> The conservation is ensured only for isotropic scattering.  |
| CACB         | keyword to specify that CACTUS type uniformly distributed integration polar angles are to be selected for the method of characteristics. <sup>[50]</sup> The conservation is ensured only for isotropic scattering.   |
| <i>nmu</i>   | user-defined number of polar angles for the integration of the tracks with the method of characteristics for 2D geometries. By default, a value consistent with <i>nangl</i> is computed by the code. For LCMD, OPP1, OGAU quadratures, <i>nmu</i> is limited to 2, 3 or 4.                                 |
| DIFC         | keyword used to specify that only an ACA-simplified transport flux calculation is to be performed (not by default). In this case, the maximum number of ACA iterations is set to <i>nmaxi</i> .   |
| LEXA         | keyword used to force the usage of exact exponentials in the preconditioner calculation (not by default).   |
| MAXI         | keyword to specify the maximum number of scattering iterations performed in each energy group. This keyword is also used to set the number of Bi-CGSTAB iterations to solve the ACA-simplified system if DIFC is present.   |
| <i>nmaxi</i> | the maximum number of iterations. The default value is <i>nmaxi</i> =20.  |
| EPSI         | keyword to specify the convergence criterion on inner iterations (or ACA-simplified flux calculation if DIFC is present).   |
| <i>xepsi</i> | convergence criterion. The default value is <i>xepsi</i> = $1.0 \times 10^{-5}$ .   |
| AAC          | keyword to set the ACA preconditioning of inner/multigroup iterations in case where a transport solution is selected. <sup>[24, 30]</sup>   |
| <i>iaca</i>  | 0/> 0: ACA preconditioning of inner or multigroup iterations off/on. The default value is <i>iaca</i> =1. If MAXI is set to 1, ACA is used as a rebalancing technique for multigroup-inner mixed iterations and <i>iaca</i> is the maximum number of iterations allowed to solve the ACA system (e.g. 100). |
| NONE         | no preconditioning for the iterative resolution by Bi-CGSTAB of the ACA system.   |
| DIAG         | diagonal preconditioning for the iterative resolution by Bi-CGSTAB of the ACA system.   |

|              |  |
|--------------|--|
| FULL         | full-matrix preconditioning for the iterative resolution by Bi-CGSTAB of the ACA system.   |
| ILU0         | ILU0 preconditioning for the iterative resolution by Bi-CGSTAB of the ACA system (This is the default option).   |
| TMT          | two-step collapsing version of ACA which uses a tracking merging technique while building the ACA matrices.  |
| SCR          | keyword to set the SCR preconditioning of inner/multigroup iterations. <sup>[33]</sup>   |
| <i>iscr</i>  | 0/> 0: SCR preconditioning of inner or multigroup iterations off/on. The default value is <i>iscr</i> =0. If MAXI is set to 1, SCR is used as a rebalancing technique for multigroup-inner mixed iterations and <i>iscr</i> is the maximum number of iterations allowed to solve the SCR system. When anisotropic scattering is considered, SCR provides an acceleration of anisotropic flux moments. If both ACA and SCR are selected ( <i>iscr</i> > 0 and <i>iaca</i> > 0), a two-step acceleration scheme (equivalent to ACA when isotropic scattering is considered) involving both methods is used.  |
| KRYL         | keyword to enable the Krylov acceleration of scattering iterations performed in each energy group. <sup>[33]</sup>   |
| <i>ikryl</i> | 0: GMRES/Bi-CGSTAB acceleration not used; > 0: dimension of the Krylov subspace in GMRES; < 0: Bi-CGSTAB is used. The default value is <i>ikryl</i> =10.   |
| MCU          | keyword used to specify the maximum dimension of the connection matrix for memory allocation.  |
| <i>imcu</i>  | The default value is eight (resp. twelve) times the number of volumes and external surfaces for 2D (resp. 3D) geometries.  |
| HDD          | keyword to select the integration scheme along the tracking lines.   |
| <i>xhdd</i>  | selection criterion: <div style="text-align: center; margin: 10px 0;"> <math display="block">xhdd = \begin{cases} 0.0 &amp; \text{step characteristics scheme} \\ &gt; 0.0 &amp; \text{diamond differencing scheme.} \end{cases}</math> </div> <p>The default value is <i>xhdd</i>=0.0 so that the step characteristics method is used.</p>  |
| LEXF         | keyword used to force the usage of exact exponentials in the flux calculation (not by default).  |
| SC           | keyword used to select the step characteristics (SC) or DD0 diamond differencing approximation. This option is a flat source approximation (default option).   |
| LDC          | keyword used to select the linear discontinuous characteristics (LDC) or DD1 diamond differencing approximation. This option is a linear source approximation.   |
| STIS         | keyword to select the tracking integration strategy.   |
| <i>istis</i> | 0: a direct approach with asymptotical treatment is used; 1: a “source term isolation” approach with asymptotical treatment is used (this technique tends to reduce the computational cost and increase the numerical stability but requires the calculation of angular mode-to-mode self-collision probabilities); -1: an ”MOCC/MCI”-like approach is used (it tends to reduce further more the computational cost as it doesn’t feature any asymptotical treatment for vanishing optical thicknesses). Note that when a zero total cross section is found with <i>istis</i> =-1, it is reset to 1. The default value is <i>istis</i> =1 for $P_{L \leq 3}$ anisotropy and 0 otherwise. |
| ADJ          | keyword to select an adjoint solution of ACA and characteristics systems. A direct solution is set by default.   |

## 3.4.5 The SNT: tracking module

The SNT: module can process one-dimensional, two-dimensional regular geometries and three-dimensional Cartesian geometries of type CAR1D, TUBE, SPHERE, CAR2D, TUBEZ and CAR3D.

The calling specification for this module is:

Table 32: Structure (SNT:)

```
TRKNAM := SNT: [ TRKNAM ] GEONAM :: (desctrack) (descsn)
```

where

**TRKNAM**      **character\*12** name of the TRACKING data structure that will contain region volume and surface area vectors in addition to region identification pointers and other tracking information. If *TRKNAM* also appears on the RHS, the previous tracking parameters will be applied by default on the current geometry.

**GEONAM**      **character\*12** name of the GEOMETRY data structure.

**(desctrack)**    structure describing the general tracking data (see Section 3.4)

**(descsn)**        structure describing the transport tracking data specific to SNT:.

The SNT: specific tracking data in **(descsn)** is defined as

Table 33: Structure (descsn)

```
[ { ONEG | ALLG } ] [ { OMPA | OMPM m } ] [ { MPIM m } ]
[ SCHM ischm ] [ DIAM mm ]
SN n [ SCAT iscat ]
[ { LIVO icl1 icl2 | NLIVO | GMRES nstart } ]
[ { DSA ndsa mdsa sdsa | NDSA } ]
[ NSHT ]
[ FOUR nfou ]
[ MAXI maxi ] [ EPSI epsi ]
[ QUAD iquad ]
[ { BTE | BFPG | BFPL } ]
[ ESCHM eschm ] [ EDIAM emm ]
[ [ QUAB iquab ] [ { SAPO | HEBE | SLSI [ frtm ] } ] ]
;
```

where

**(desctrack)**    structure describing the general tracking data (see Section 3.4)

**ONEG**            keyword to specify that the multigroup flux is computed as a sequence of one-group solutions using Gauss-Seidel iterations. This is the default option.

|                   |   |
|-------------------|---|
| ALLG              | keyword to specify that the multigroup flux is computed in parallel for a set of energy groups.   |
| OMPA              | keyword to specify that standard energy group (if ALLG enabled) and discrete angle nested loops are used for OpenMP multithreading in 2D and 3D geometries. This is the default option.   |
| OMPM              | keyword to specify that Domino type nested loops with parallelisation over both angles and macrocells are used for OpenMP multithreading in 2D and 3D geometries. <sup>[31]</sup>   |
| MPIM              | keyword to specify that parallelisation using MPI in WYVERN will be used. This is required to build the graph arrays for the sweep in hexagonal geometries.   |
| <i>m</i>          | use $m \times m$ or $m \times m \times m$ macrocells in Domino swapping.  |
| SCHM              | keyword to specify the spatial discretisation scheme.   |
| <i>ischm</i>      | index to specify the spatial discretisation scheme. <i>ischm</i> = 1 is used for High-Order Diamond Differencing (HODD) (default value). <i>ischm</i> = 2 is used for the Discontinuous Galerkin finite element method (DG) currently available only in 1D slab, and 2D/3D Cartesian/hexagonal geometries. <i>ischm</i> = 3 is used for the Adaptive Weighted Difference method (AWD), only available for Cartesian geometries.   |
| DIAM              | keyword to fix the spatial approximation order.   |
| <i>mm</i>         | order of the Legendre polynomial expansion used in the spatial discretisation method. For HODD, <i>mm</i> = 0 is the default, while for DG, it is <i>mm</i> = 1. For Cartesian geometries, any order $mm \geq 0$ is available. For 2D hexagonal geometries, linear and parabolic orders are available. Classical diamond difference ( <i>mm</i> = 0 with <i>ischm</i> = 1) are available for 1D tube and 1D sphere geometries. Adaptive schemes ( <i>ischm</i> = 3) are only available with constant order. |
|                   | $mm = \begin{cases} 0 & \text{Constant (classical diamond scheme (HODD) or step scheme (DG))} \\ 1 & \text{Linear} \\ 2 & \text{Parabolic} \\ > 3 & \text{Higher-orders} \end{cases}$   |
| SN                | keyword to fix the angular approximation order of the flux.   |
| <i>n</i>          | order of the $S_N$ approximation (even number).   |
| SCAT              | keyword to limit the anisotropy of scattering sources.  |
| <i>iscat</i>      | number of terms in the scattering sources. <i>iscat</i> = 1 is used for isotropic scattering in the laboratory system. <i>iscat</i> = 2 is used for linearly anisotropic scattering in the laboratory system. The default value is set to <i>n</i> .  |
| LIVO              | keyword to enable Livolant acceleration of the scattering iterations (default value).   |
| <i>icl1, icl2</i> | Numbers of respectively free and accelerated iterations in the Livolant method.   |
| NLIVO             | keyword to disable acceleration method and to perform free scattering iterations  |
| GMRES             | keyword to set the GMRES(m) acceleration of the scattering iterations. The default value, equivalent to <i>nstart</i> =0, corresponds to a one-parameter Livolant acceleration. <sup>[33]</sup>   |
| <i>nstart</i>     | restarts the GMRES method every <i>nstart</i> iterations.   |
| DSA               | keyword to enable diffusion synthetic acceleration using BIVAC or TRIVAC.   |

*ndsa* apply the synthetic acceleration every *ndsa* number of inner flux iterations. Depending on the test case, if the DSA is enabled too soon or enabled at every inner iteration, instabilities and convergence failure can occur. A value of 0 can be set to start the DSA immediately and have the acceleration applied every inner iteration thereafter. The default is *nsdsa* = 1000, indicating the DSA will not be applied. Benchmarks suggests that the optimal values are 3 and 5 for Cartesian and hexagonal geometries respectively.

*mdsa* order of the Raviart-Thomas spatial approximation used in the DSA resolution. Sometimes, using the same order as the transport calculation does not provide any benefit to the solution, and ends up being a drain on computational resources. Hence, there is the option of using a different order than the transport approximation.

$$mdsa = \begin{cases} 0 & \text{Constant} \\ 1 & \text{Linear} \\ 2 & \text{Parabolic} \end{cases}$$

*sdsa* choose the solver to use for the synthetic acceleration. Note that TRIVAC generally works better and is faster with hexagonal geometries for the matrix assemblies. Also, for 3D geometries, TRIVAC *has* to be chosen.

$$sdsa = \begin{cases} 1 & \text{BIVAC} \\ 2 & \text{TRIVAC} \end{cases}$$

NDSA keyword to disable diffusion synthetic acceleration (default).

NSHT keyword to disable the shooting method for 1D cases – can be useful for debugging purposes.

FOUR keyword to pass the number of frequencies to be investigated in Fourier analysis (only works in 1D Cartesian geometry).

*nfou* number of frequencies to be investigated in 1D Fourier analysis along the range  $[0, \frac{2\pi}{L}]$  where  $L$  is the length of the slab.

MAXI keyword to set the maximum number of inner iterations (or GMRES iterations if activated).

*maxi* maximum number of inner iterations. Default value: 100.

EPSI set the convergence criterion on inner iterations (or GMRES iterations if activated).

*epsi* convergence criterion on inner iterations. The default value is  $1 \times 10^{-5}$ .

QUAD keyword to set the type of angular quadrature.

*iquad* type of quadrature: = 1: Lathrop-Carlson level-symmetric quadrature; = 2:  $\mu_1$ -optimized level-symmetric quadrature (default option in 2D and in 3D); = 3 Snow-code level-symmetric quadrature (obsolete); = 4: Legendre-Chebyshev quadrature (variable number of base points per axial level); = 5: symmetric Legendre-Chebyshev quadrature; = 6: quadruple range (QR) quadrature;<sup>[34]</sup> = 10: product of Gauss-Legendre and Gauss-Chebyshev quadrature (equal number of base points per axial level).

BTE solution of the Boltzmann transport equation (default option).

BFPG solution of the Boltzmann Fokker-Planck equation with Galerkin energy propagation factors.

BFPL solution of the Boltzmann Fokker-Planck equation with Przybylski and Ligou energy propagation factors.<sup>[32]</sup>

ESCHM keyword to specify the energy discretisation scheme to use for the continuous slowing-down term of the Boltzmann Fokker-Planck equation.

|              |  |
|--------------|--|
| <i>eschk</i> | index to specify the energy discretisation scheme. <i>ischm</i> = 1 is used for High-Order Diamond Differencing (HODD) (default value). <i>ischm</i> = 2 is used for the Discontinuous Galerkin finite element method (DG). <i>ischm</i> = 3 is used for the Adaptive Weighted Difference method (AWD). All of these schemes are available only for Cartesian geometries.  |
| EDIAM        | keyword to fix the energy approximation order.   |
| <i>emm</i>   | order of the Legendre polynomial expansion used in the energy discretisation method. For HODD, <i>mm</i> = 0 is the default, while for DG, it is <i>mm</i> = 1. For Cartesian geometries, any order <i>mm</i> ≥ 0 is available. Adaptive schemes ( <i>ischm</i> = 3) are only available with constant order.   |
|              | $mm = \begin{cases} 0 & \text{Constant (classical diamond scheme (HODD) or step scheme (DG))} \\ 1 & \text{Linear} \\ 2 & \text{Parabolic} \\ > 3 & \text{Higher-orders} \end{cases}$  |
| QUAB         | keyword to specify the number of basis point for the numerical integration of each microstructure in cases involving double heterogeneity (Bihet).   |
| <i>iquab</i> | the number of basis point for the numerical integration of the collision probabilities in the micro-volumes using the Gauss-Jacobi formula. The values permitted are: 1 to 20, 24, 28, 32 or 64. The default value is <i>iquab</i> =5. If <i>iquab</i> is negative, its absolute value will be used in the She-Liu-Shi approach to determine the split level in the tracking used to compute the probability collisions. |
| SAP0         | use the Sanchez-Pomraning double-heterogeneity model. <sup>[51]</sup>  |
| HEBE         | use the Hebert double-heterogeneity model (default option). <sup>[52]</sup>  |
| SLSI         | use the She-Liu-Shi double-heterogeneity model without shadow effect. <sup>[53]</sup>  |
| <i>frtm</i>  | the minimum microstructure volume fraction used to compute the size of the equivalent cylinder in She-Liu-Shi approach. The default value is <i>frtm</i> = 0.05.   |

### 3.4.6 The BIVACT: tracking module

The BIVACT: module can only process 1D/2D regular geometries of type CAR1D, CAR2D and HEX. The geometry is analyzed and a LCM object with signature L\_BIVAC is created with the tracking information.

The calling specification for this module is:

Table 34: Structure (**BIVACT:**)

```
TRKNAM := BIVACT: [ TRKNAM ] GEONAM :: (desctrack) (descbivac)
```

where

**TRKNAM**      **character\*12** name of the TRACKING data structure that will contain region volume and surface area vectors in addition to region identification pointers and other tracking information. If *TRKNAM* also appears on the RHS, the previous tracking parameters will be applied by default on the current geometry.

**GEONAM**      **character\*12** name of the GEOMETRY data structure.

**(desctrack)**    structure describing the general tracking data (see Section 3.4)

**(descbivac)**    structure describing the transport tracking data specific to BIVACT:.

The BIVACT: specific tracking data in (**descbivac**) is defined as

Table 35: Structure (**descbivac**)

```
[ { PRIM [ ielem icol ]
  | DUAL [ ielem icol ]
  | MCFD } ]
[ { PN | SPN } n [ SCAT [ DIFF ] iscat ] [ VOID nvd ] ]
;
```

where

**(desctrack)**    structure describing the general tracking data (see Section 3.4)

**PRIM**          keyword to set a primal finite element (classical) discretization.

**DUAL**          keyword to set a mixed-dual finite element discretization. If the geometry is hexagonal, a Thomas-Raviart-Schneider method is used.

**MCFD**          keyword to set a mesh-centered finite difference discretization in hexagonal geometry.

**ielem**          order of the finite element representation. The values permitted are: 1 (linear polynomials), 2 (parabolic polynomials), 3 (cubic polynomials) or 4 (quartic polynomials). By default *ielem*=1.

**icol**            type of quadrature used to integrate the mass matrices. The values permitted are: 1 (analytical integration), 2 (Gauss-Lobatto quadrature) or 3 (Gauss-Legendre quadrature).



By default  $icol=2$ . The analytical integration corresponds to classical finite elements; the Gauss-Lobatto quadrature corresponds to a variational or nodal type collocation and the Gauss-Legendre quadrature corresponds to superconvergent finite elements.

|              |   |
|--------------|---|
| PN           | keyword to set a spherical harmonics ( $P_n$ ) expansion of the flux. <sup>[59]</sup> This option is currently limited to 1D and 2D Cartesian geometries.   |
| SPN          | keyword to set a simplified spherical harmonics ( $SP_n$ ) expansion of the flux. <sup>[59, 60]</sup> This option is currently available with 1D and 2D Cartesian geometries and with 2D hexagonal geometries.  |
| $n$          | order of the $P_n$ or $SP_n$ expansion (odd number). Set to zero for diffusion theory (default value).  |
| SCAT         | keyword to limit the anisotropy of scattering sources.  |
| DIFF         | keyword to force using $1/3D^g$ as $\Sigma_1^g$ cross sections. A $P_1$ or $SP_1$ method will therefore behave as diffusion theory.   |
| <i>iscat</i> | number of terms in the scattering sources. $iscat = 1$ is used for isotropic scattering in the laboratory system. $iscat = 2$ is used for linearly anisotropic scattering in the laboratory system. The default value is set to $n + 1$ in $P_n$ or $SP_n$ case.              |
| VOID         | key word to set the number of base points in the Gauss-Legendre quadrature used to integrate void boundary conditions if $icol = 3$ and $n \neq 0$ .  |
| <i>nvd</i>   | type of quadrature. The values permitted are: 0 (use a $(n+2)$ -point quadrature consistent with $P_n$ theory), 1 (use a $(n+1)$ -point quadrature consistent with $S_{n+1}$ theory), 2 (use an analytical integration of the void boundary conditions). By default $nvd=0$ . |

Various finite element approximations can be obtained by combining different values of *ielem* and *icol*:

- PRIM 1 1 : Linear finite elements;
- PRIM 1 2 : Mesh corner finite differences;
- PRIM 1 3 : Linear superconvergent finite elements;
- PRIM 2 1 : Quadratic finite elements;
- PRIM 2 2 : Quadratic variational collocation method;
- PRIM 2 3 : Quadratic superconvergent finite elements;
- PRIM 3 1 : Cubic finite elements;
- PRIM 3 2 : Cubic variational collocation method;
- PRIM 3 3 : Cubic superconvergent finite elements;
- PRIM 4 2 : Quartic variational collocation method;
- DUAL 1 1 : Mixed-dual linear finite elements;
- DUAL 1 2 : Mesh centered finite differences;
- DUAL 1 3 : Mixed-dual linear superconvergent finite elements  
(numerically equivalent to PRIM 1 3);
- DUAL 2 1 : Mixed-dual quadratic finite elements;
- DUAL 2 2 : Quadratic nodal collocation method;

- DUAL 2 3 : Mixed-dual quadratic superconvergent finite elements  
(numerically equivalent to PRIM 2 3);
- DUAL 3 1 : Mixed-dual cubic finite elements;
- DUAL 3 2 : Cubic nodal collocation method;
- DUAL 3 3 : Mixed-dual cubic superconvergent finite elements  
(numerically equivalent to PRIM 3 3);
- DUAL 4 2 : Quartic nodal collocation method;

### 3.4.7 The TRIVAT: tracking module

The TRIVAT: module is used to perform a TRIVAC-type “tracking” on a 1D/2D/3D regular Cartesian or hexagonal geometry.<sup>[57,58]</sup> The geometry is analyzed and a LCM object with signature L\_TRIVAC is created with the following information:

- Diagonal and hexagonal symmetries are unfolded and the mesh-splitting operations are performed. Volumes, material mixture and averaged flux recovery indices are computed on the resulting geometry.
- A finite element discretization is performed and the corresponding numbering is saved.
- The unit finite element matrices (mass, stiffness, etc.) are recovered.
- Indices related to an ADI preconditioning with or without supervectorization are saved.

The calling specification for this module is:

Table 36: Structure (TRIVAT:)

```
TRKNAM := TRIVAT: [ TRKNAM ] GEONAM :: (desctrack) (descTRIVAC)
```

where

**TRKNAM**      **character\*12** name of the TRACKING data structure that will contain region volume and surface area vectors in addition to region identification pointers and other tracking information. If *TRKNAM* also appears on the RHS, the previous tracking parameters will be applied by default on the current geometry.

**GEONAM**      **character\*12** name of the GEOMETRY data structure.

**(desctrack)**    structure describing the general tracking data (see Section 3.4)

**(descTRIVAC)** structure describing the transport tracking data specific to TRIVAT:.

The TRIVAT: specific tracking data in **(descTRIVAC)** is defined as

Table 37: Structure (descTRIVAC)

```
[ { PRIM [ ielem ] | DUAL [ ielem icol ] | MCFD [ ielem ] | LUMP [ ielem ] } ]
[ SPN n [ SCAT [ DIFF ] iscat ] [ VOID nvd ] ]
[ ADI nadi ]
[ VECT [ iseg ] [ PRTV impv ] ]
;
```

where

**(desctrack)** structure describing the general tracking data (see Section 3.4)

**PRIM**          key word to set a discretization based on the variational collocation method.

|              |  |
|--------------|--|
| DUAL         | key word to set a mixed-dual finite element discretization. If the geometry is hexagonal, a Thomas-Raviart-Schneider method is used.   |
| MCFD         | key word to set a discretization based on the nodal collocation method. The mesh centered finite difference approximation is the default option and is generally set using MCFD 1. The MCFD approximations are numerically equivalent to the DUAL approximations with <i>icol</i> =2; however, the MCFD approximations are less expensive.   |
| LUMP         | key word to set a discretization based on the nodal collocation method with serendipity approximation. The serendipity approximation is different from the MCFD option in cases with <i>ielem</i> ≥2. This option is not available for hexagonal geometries.   |
| <i>ielem</i> | order of the finite element representation. The values permitted are: 1 (linear polynomials), 2 (parabolic polynomials), 3 (cubic polynomials) or 4 (quartic polynomials). By default <i>ielem</i> =1.   |
| <i>icol</i>  | type of quadrature used to integrate the mass matrices. The values permitted are: 1 (analytical integration), 2 (Gauss-Lobatto quadrature) or 3 (Gauss-Legendre quadrature). By default <i>icol</i> =2. The analytical integration corresponds to classical finite elements; the Gauss-Lobatto quadrature corresponds to a variational or nodal type collocation and the Gauss-Legendre quadrature corresponds to superconvergent finite elements. |
| SPN          | keyword to set a simplified spherical harmonics ( $SP_n$ ) expansion of the flux. <sup>[59,60]</sup> This option is available with 1D, 2D and 3D Cartesian geometries and with 2D and 3D hexagonal geometries.   |
| <i>n</i>     | order of the $P_n$ or $SP_n$ expansion (odd number). Set to zero for diffusion theory (default value).   |
| SCAT         | keyword to limit the anisotropy of scattering sources.   |
| DIFF         | keyword to force using $1/3D^g$ as $\Sigma_1^g$ cross sections. A $P_1$ or $SP_1$ method will therefore behave as diffusion theory.  |
| <i>iscat</i> | number of terms in the scattering sources. <i>iscat</i> = 1 is used for isotropic scattering in the laboratory system. <i>iscat</i> = 2 is used for linearly anisotropic scattering in the laboratory system. The default value is set to $n + 1$ in $P_n$ or $SP_n$ case.   |
| VOID         | key word to set the number of base points in the Gauss-Legendre quadrature used to integrate void boundary conditions if <i>icol</i> = 3 and $n \neq 0$ .  |
| <i>nvd</i>   | type of quadrature. The values permitted are: 0 (use a $(n+2)$ -point quadrature consistent with $P_n$ theory), 1 (use a $(n+1)$ -point quadrature consistent with $S_{n+1}$ theory), 2 (use an analytical integration of the void boundary conditions). By default <i>nvd</i> =0.   |
| ADI          | keyword to set the number of ADI iterations at the inner iterative level.  |
| <i>nadi</i>  | number of ADI iterations (default: <i>nadi</i> = 2).   |
| VECT         | key word to set an ADI preconditioning with supervectorization. By default, TRIVAC uses an ADI preconditioning without supervectorization.   |
| <i>iseg</i>  | width of a vectorial register. <i>iseg</i> is generally a multiple of 64. By default, <i>iseg</i> =64.   |
| PRTV         | key word used to set <i>impv</i> .   |
| <i>impv</i>  | index used to control the printing in supervectorization subroutines. =0 for no print; =1 for minimum printing (default value); Larger values produce increasing amounts of output.  |

Various finite element approximations can be obtained with different values of *ielem*.

### 3.5 The ASM: module

We will now describe the assembly modules which can be used to prepare the group-dependent complete collision probability or the assembly matrices required by the flux solution module of DRAGON. The assembly module **ASM:** is generally called after a tracking module; it recovers tracking lengths and material numbers from the sequential tracking file and then computes the collision probability or group-dependent system matrices under various normalizations. The calling specifications are:

Table 38: Structure (**ASM:**)

```
PIJNAM := ASM: [ PIJNAM ] LIBNAM TRKNAM [ TRKFIL ] :: (descasm)
```

where

|                  |   |
|------------------|---|
| <i>PIJNAM</i>    | <b>character*12</b> name of ASMPIJ data structure containing the system matrices. If <i>PIJNAM</i> appears on the RHS, the ( <b>descasm</b> ) information previously stored in <i>PIJNAM</i> is kept.       |
| <i>LIBNAM</i>    | <b>character*12</b> name of the MACROLIB or MICROLIB data structure that contains the macroscopic cross sections (see Sections 3.1 and 3.2).  |
| <i>TRKNAM</i>    | <b>character*12</b> name of the TRACKING data structure containing the tracking (see Section 3.4).  |
| <i>TRKFIL</i>    | <b>character*12</b> name of the sequential binary tracking file used to store the tracks lengths. This file is given if and only if it was required in the previous tracking module call (see Section 3.4). |
| <b>(descasm)</b> | structure containing the input data to this module (see Section 3.5.1).   |

#### 3.5.1 Data input for module ASM:

Table 39: Structure (**descasm**)

```
[ EDIT iprint ]
[ { ARM |
  { PIJ | PIJK } [ SKIP ]
  [ { NORM | ALBS } ]
  [ PNOR { NONE | DIAG | GELB | HELI | NONL } ]
} ]
[ { ECCO | HETE } ]
;
```

where

|               |   |
|---------------|---|
| EDIT          | keyword used to modify the print level <i>iprint</i> .                              |
| <i>iprint</i> | index used to control the printing of this module. The amount of output produced by |

this tracking module will vary substantially depending on the print level specified.

- ARM** keyword to specify that an assembly calculation is carried out without building the full collision probability matrices. This option can only be used for a geometry tracked using the **SYBILT**: (with **EURYDICE-2** option), **MCCGT**: or **SNT**: module. By default, the **PIJ** option is used.
- PIJ** keyword to specify that the standard scattering-reduced collision probabilities must be computed. This option cannot be used with the **MCCGT**: and **SNT**: modules. This is the default option.
- PIJK** keyword to specify that both the directional and standard scattering-reduced collision probabilities must be computed. Moreover, the additional directional collision probability matrix can only be used if **HETE** is activated in Section 3.6. Finally, the **PIJK** option is only available for 2-D geometries analyzed with the operator **EXCELT**: with collision probability option. By default, the **PIJ** option is used.
- SKIP** keyword to specify that only the reduced collision probability matrix  $p_{ij}^g$  is to be computed. In general, the scattering modified collision probability matrix  $p_{s,ij}^g$  is also computed using:

$$p_{s,ij}^g = [I - p_{ij}^g \Sigma_{s0}^{g \rightarrow g}]^{-1} p_{ij}^g$$

where  $\Sigma_{s0}^{g \rightarrow g}$  is the within group isotropic scattering cross section. When available,  $p_{s,ij}^g$  is used in the flux solution module in such a way that for the groups where there is no up-scattering, the thermal iteration is automatically deactivated. In the case where the **SKIP** option is activated, the  $p_{ij}^g$  matrix is used and thermal iterations are required in every energy group. Consequently, the total number of inner iterations is greatly increased.

- NORM** keyword to specify that the scattering-reduced collision probability matrix is to be normalized in such a way as to eliminate all neutron loss (even if the region under consideration has external albedo boundary conditions which should result in neutron loss). When used with a void boundary condition (zero reentrant current), this option is equivalent to imposing *a posteriori* a uniform reentrant current.
- ALBS** keyword to specify that a consistent Selengut normalization of the scattering-reduced collision probability matrix is to be used both for the flux solution module (see Section 3.6) and in the equivalence calculation (see Section 3.7). This keyword results in storing the scattering-reduced escape probabilities  $W_{iS}$  in the record named 'DRAGON-WIS'. For all the cases where this option is used, it is necessary to define a geometry with **VOID** external boundary conditions (see Section 3.3).
- PNOR** keyword to specify that the collision, leakage and escape probability matrices are to be normalized in such a way as to satisfy explicitly the neutron conservation laws. This option compensates for the errors which will arise in the numerical evaluation of these probabilities and may result in non-conservative collision probability matrices. The default option is now **HELI** while it was formerly **GELB** (**Revision 3.03**).
- NONE** keyword to specify that the probability matrices are not to be renormalized.
- DIAG** keyword to specify that only the diagonal element of the probability matrices will be modified in order to insure the validity of the conservation laws.
- GELB** keyword to specify that the Gelbard algorithm will be used to normalize the collision probability matrices.<sup>[67]</sup>
- HELI** keyword to specify that the Helios algorithm will be used to normalize the collision probability matrices.<sup>[68]</sup>
- NONL** keyword to specify that a non-linear multiplicative algorithm will be used to normalize the collision probability matrices.<sup>[67]</sup>

- ECCO keyword used to compute the  $P_1$ -scattering reduced collision probability or system matrices required by the ECCO isotropic streaming model. By default, this information is not calculated.
- HETE keyword used to compute the information required by a method of characteristics (MOC) solution of the TIBERE anisotropic streaming model. By default, this information is not calculated.

### 3.6 The FLU: module

The FLU: module is used to solve the linear system of multigroup collision probability or response matrix equations in DRAGON. Different types of solution are available, such as fixed source problem, fixed source eigenvalue problem (GPT type) or different types of eigenvalue problems. The calling specifications are:

Table 40: Structure (FLU:)

```
FLUNAM := FLU: [ { FLUNAM | FLUDSA } ] PIJNAM LIBNAM TRKNAM [ TRKFIL ]
[ { TRKFLP TRKGPT | SOUNAM } ] :: (descflu)
```

where

|                    |  |
|--------------------|--|
| <i>FLUNAM</i>      | <b>character*12</b> name of the FLUXUNK data structure containing the solution (L_FLUX signature). If <i>FLUNAM</i> appears on the RHS, the solution previously stored in <i>FLUNAM</i> (flux and buckling) is used to initialize the new iterative process; otherwise, a uniform unknown vector and a zero buckling are used.   |
| <i>FLUDSA</i>      | <b>character*12</b> name of the FLUXUNK data structure containing an initial approximation of the solution (L_FLUX signature). This solution corresponds to a DSA-type simplified calculation compatible with <i>FLUNAM</i> . This option is only available with a SNT: tracking.  |
| <i>PIJNAM</i>      | <b>character*12</b> name of the ASMPIJ data structure containing the group-dependent system matrices (L_PIJ signature, see Section 3.5).   |
| <i>LIBNAM</i>      | <b>character*12</b> name of the MACROLIB or MICROLIB data structure that contains the macroscopic cross sections (L_MACROLIB or L_LIBRARY signature, see Sections 3.1 and 3.2). Module FLU: is performing a <i>direct</i> or <i>adjoint</i> calculation, depending if the adjoint flag is set to <code>.false.</code> or <code>.true.</code> in the STATE-VECTOR record of the MACROLIB. |
| <i>TRKNAM</i>      | <b>character*12</b> name of the TRACKING data structure containing the tracking (L_TRACK signature, see Section 3.4).  |
| <i>TRKFIL</i>      | <b>character*12</b> name of the sequential binary tracking file used to store the tracks lengths. This file is given if and only if it was required in the previous tracking module call (see Section 3.4).  |
| <i>TRKFLP</i>      | <b>character*12</b> name of the FLUXUNK data structure containing the unperturbed flux used to decontaminate the GPT solution (L_FLUX signature). This object is mandatory if and only if “TYPE P” is selected.  |
| <i>TRKGPT</i>      | <b>character*12</b> name of the SOURCE data structure containing the GPT fixed sources (L_SOURCE signature). This object is mandatory if and only if “TYPE P” is selected.   |
| <i>SOUNAM</i>      | <b>character*12</b> name of the SOURCE data structure containing the fixed sources (L_SOURCE signature) used for a “TYPE S” calculation. By default, piecewise-constant fixed sources available in the MACROLIB (or MICROLIB) <i>LIBNAM</i> are used.  |
| ( <b>descflu</b> ) | structure containing the input data to this module (see Section 3.6.1).  |



## 3.6.1 Data input for module FLU:

Table 41: Structure (**descflu**)

```
[ EDIT iprint ]
[ INIT { OFF | ON | DSA } ]
TYPE { N | S | F | P | K [ (descleak) ] | {B | L } (descleak) } ]
[ EXTE [ maxout ] [ epsout ] ]
[ THER [ maxthr ] [ epsthr ] ] [ REBA [ OFF ] ]
[ UNKT [ epsunk ] ]
[ ACCE nlibre naccel ]
;
```

where

|               |   |
|---------------|---|
| EDIT          | keyword used to modify the print level <i>iprint</i> .  |
| <i>iprint</i> | index used to control the printing of this operator. The amount of output produced by this operator will vary substantially depending on the print level specified.   |
| OFF           | keyword to specify that the neutron flux is to be initialized with a flat distribution (default option).  |
| ON            | keyword to specify that the initial neutron flux distribution is to be recovered from <i>FLUNAM</i> if present in the RHS arguments.  |
| DSA           | keyword to specify that the initial neutron flux distribution is to be recovered from the DSA compatible data structure <i>FLUDSA</i> if present in the RHS arguments. This option is only available with a <b>SNT</b> : tracking.  |
| TYPE          | keyword to specify the type of solution used in the flux operator.  |
| N             | keyword to specify that no flux calculation is to be performed. This option is usually activated when one simply wishes to initialize the neutron flux distribution and to store this information in <i>FLUNAM</i> .  |
| S             | keyword to specify that a fixed source problem is to be treated. Such problem can also include fission source contributions.  |
| F             | keyword to specify that a 1D Fourier analysis calculation in $S_n$ is to be treated. This is similar to a fixed source problem, but the calculation stopped early to compute an L2 error norm in the flux. This yields a numerical estimate of the eigenvalue for the scattering source equation. |
| P             | keyword to specify that a fixed source eigenvalue problem (GPT type) is to be treated. Such problem includes fission source contributions in addition of GPT sources.   |
| K             | keyword to specify that a fission source eigenvalue problem is to be treated. The eigenvalue is then the effective multiplication factor with a fixed buckling. In this case, the fixed sources, if any is present on the <b>MACROLIB</b> or <b>MICROLIB</b> data structure, are not used.        |

|                     |  |
|---------------------|--|
| B                   | keyword to specify that a fission source eigenvalue problem is to be treated. The eigenvalue in this case is the critical buckling with a fixed effective multiplication factor. The buckling eigenvalue has meaning only in the case of a cell without leakages (see the structure ( <b>descBC</b> ) in Section 3.3.2). It is also possible to use an open geometry with VOID boundary conditions provided it is closed by the ASM: module (see Section 3.5.1) using the keywords NORM or ALSB.     |
| L                   | keyword to specify that a non-multiplicative medium eigenvalue problem is to be treated. The eigenvalue in this case is the critical buckling with vanishing fission cross sections. The buckling eigenvalue has meaning only in the case of a cell without leakages (see the structure ( <b>descBC</b> ) in Section 3.3.2). It is also possible to use an open geometry with VOID boundary conditions provided it is closed by the ASM: module (see Section 3.5.1) using the keywords NORM or ALSB. |
| ( <b>descleak</b> ) | structure describing the general leakage parameters options (see Section 3.6.2). This information is mandatory for producing the diffusion coefficients.   |
| EXTE                | keyword to specify that the control parameters for the external iteration are to be modified.  |
| <i>maxout</i>       | maximum number of external iterations. The fixed default value for a case with no leakage model is $maxout=2 \times n_f - 1$ where $n_f$ is the number of regions containing fuel. The fixed default value for a case with a leakage model is $maxout=10 \times n_f - 1$ .   |
| <i>epsout</i>       | convergence criterion for the external iterations. The fixed default value is $epsout=5.0 \times 10^{-5}$ .  |
| THER                | keyword to specify that the control parameters for the thermal iterations are to be modified.  |
| <i>maxthr</i>       | maximum number of thermal iterations. The fixed default value is $maxthr=2 \times ngroup-1$ (using scattering modified CP) or $maxthr=4 \times ngroup-1$ (using standard CP).  |
| <i>epsthr</i>       | convergence criterion for the thermal iterations. The fixed default value is $epsthr=5.0 \times 10^{-5}$ .   |
| UNKT                | keyword to specify the flux error tolerance in the outer iteration.  |
| <i>epsunk</i>       | convergence criterion for flux components in the outer iteration. The fixed default value is $epsunk=epsthr$ .   |
| REBA                | keyword used to specify that the flux rebalancing option is to be turned on or off in the thermal iteration. By default (floating default) the flux rebalancing option is initially activated. This keyword is required to toggle between the on and off position of the flux rebalancing option.  |
| OFF                 | keyword used to deactivate the flux rebalancing option. When this keyword is absent the flux rebalancing option is reactivated.  |
| ACCE                | keyword used to modify the variational acceleration parameters. This option is active by default (floating default) with $nlibre=3$ free iterations followed by $naccel=3$ accelerated iterations.   |
| <i>nlibre</i>       | number of free iterations per cycle of $nlibre+naccel$ iterations.   |
| <i>naccel</i>       | number of accelerated iterations per cycle of $nlibre+naccel$ iterations. Variational acceleration may be deactivated by using $naccel=0$ .  |

### 3.6.2 Leakage model specification structure

Without leakage model, the multigroup flux  $\vec{\phi}_g$  of the collision probability method is obtained from equation

$$\vec{\phi}_g = \mathbf{W}_g \vec{Q}_g^* \quad (3.9)$$

where  $\mathbf{W}_g$  is the scattering reduced collision probability matrix and  $Q_g^*$  is the fission and out-of-group scattering source. This equation is modified by the leakage model. The leakage models PNLR, PNL, SIGS (default model) and ECCO can also be used with solutions techniques other than the collision probability method.

A leakage model can be set in *fundamental mode condition* if all boundary conditions are conservative (such as REFL, SYME, SSYM, DIAG, ALBE 1.0). In this case, the (**descleak**) structure allows the following information to be specified:

Table 42: Structure (**descleak**) in fundamental mode condition

```
{ LKRD | RHS | P0 | P1 | POTR | BO | B1 | BOTR }
{ PNLR | PNL | SIGS | ALBS | ECCO | HETE [ { G | R | Z | X | Y } ] }
[ { BUCK { valb2 | [ G valb2 ] [ R valbr2 ] [ Z valbz2 ] [ X valbx2 ] [ Y valby2 ] } | KEFF valk | IDEM } ]
```

If a boundary condition is non-conservative (such as VOID), it is nevertheless possible to set a simplified leakage model based on the Todorova approximation with option SIGS. Such a model is useful to represent leakage in the axial direction. The Todorova leakage model available in module FLU: is an homogeneous model assuming uniform leakage across the complete domain in each energy group. An heterogeneous model with more leakage zones is also available.

To activate the Todorova approximation, the (**descleak**) structure takes the form:

Table 43: Structure (**descleak**) in non-fundamental mode condition

```
{ LKRD | RHS | P0 | P1 | POTR }
[ MERG (imergl(ii),ii=1,nbmix) ]
[ BUCK valb2 ]
```

|      |   |
|------|---|
| LKRD | keyword used to specify that the leakage coefficients are recovered from data structure named <i>LIBNAM</i> . The LKRD option is not available with the ECCO and HETE leakage models.   |
| RHS  | keyword used to specify that the leakage coefficients are recovered from RHS flux data structure named <i>FLUNAM</i> . The RHS option is not available with the ECCO and HETE leakage models. If the flux calculation is an adjoint calculation, the energy group ordering of the leakage coefficients is permuted. |
| P0   | keyword used to specify that the leakage coefficients are calculated using a $P_0$ model.   |
| P1   | keyword used to specify that the leakage coefficients are calculated using a $P_1$ model.   |
| POTR | keyword used to specify that the leakage coefficients are calculated using a $P_0$ model with transport correction.   |

- B0** keyword used to specify that the leakage coefficients are calculated using a  $B_0$  model. This is the default value when a buckling calculation is required (**B**).
- B1** keyword used to specify that the leakage coefficients are calculated using a  $B_1$  model.
- B0TR** keyword used to specify that the leakage coefficients are calculated using a  $B_0$  model with transport correction.
- PNLR** keyword used to specify that the elements of the scattering modified collision probability matrix are multiplied by the adequate non-leakage homogeneous buckling dependent factor.<sup>[76]</sup> The non-leakage factor  $P_{\text{NLR},g}$  is defined as

$$P_{\text{NLR},g} = \frac{\bar{\Sigma}_g - \bar{\Sigma}_{s0,g\leftarrow g}}{\bar{\Sigma}_g - \bar{\Sigma}_{s0,g\leftarrow g} + d_g(B) B^2} \quad (3.10)$$

where transport-corrected total cross sections are used to compute the  $\mathbf{W}_g$  matrix.  $\bar{\Sigma}_{s0,g\leftarrow g}$  is the average transport-corrected macroscopic within-group scattering cross section in group  $g$ , homogenized over the lattice and transport corrected. Eq. (3.9) is then replaced by

$$\vec{\phi}_g = P_{\text{NLR},g} \mathbf{W}_g \vec{Q}_g^* \quad . \quad (3.11)$$

- PNL** keyword used to specify that the elements of the collision probability matrix are multiplied by the adequate non-leakage homogeneous buckling dependent factor.<sup>[76]</sup> The non-leakage factor  $P_{\text{NL},g}$  is defined as

$$P_{\text{NL},g} = \frac{\bar{\Sigma}_g}{\bar{\Sigma}_g + d_g(B) B^2} \quad (3.12)$$

where  $\bar{\Sigma}_g$  is the average transport-corrected macroscopic total cross section in group  $g$ , homogenized over the lattice and transport corrected. Eq. (3.9) is then replaced by

$$\vec{\phi}_g = \mathbf{W}_g \left[ P_{\text{NL},g} \vec{Q}_g^* - (1 - P_{\text{NL},g}) \Sigma_{s0,g\leftarrow g} \vec{\phi}_g \right] \quad (3.13)$$

where  $\Sigma_{s0,g\leftarrow g} = \text{diag}\{\Sigma_{s0,i,g\leftarrow g} ; \forall i\}$  and the total cross sections used to compute the  $\mathbf{W}_g$  matrix are also transport-corrected.

It is important to note that that the PNL option reduces to the PNL option in cases where no scattering reduction is performed. Scattering reduction can be avoided in module **ASM**: by setting **PIJ SKIP** (See Section 3.5.1).

- SIGS** keyword used to specify that an homogeneous buckling correction is to be applied on the diffusion cross section ( $\Sigma_s - dB^2$ ). Eq. (3.9) is then replaced by

$$\vec{\phi}_g = \mathbf{W}_g \left[ \vec{Q}_g^* - d_g(B) B^2 \vec{\phi}_g \right] \quad (3.14)$$

where transport-corrected total cross sections are used to compute the  $\mathbf{W}_g$  matrix. This is the so called *DIFFON method* used in the APOLLO-family of thermal lattice codes. The **SIGS** option is the default option when a buckling calculation is required (**TYPE B** or **TYPE L**) or a fission source eigenvalue problem (**TYPE K**) with imposed buckling is considered.

- ALBS** keyword used to specify that an homogeneous buckling contribution is introduced by a group dependent correction of the albedo.<sup>[77]</sup> This leakage model is restricted to the collision probability method. It is then necessary to define the geometry with an external

boundary condition of type VOID (see Section 3.3.2) and to close the region in module ASM: using the ALBS option (see Section 3.5.1). Eq. (3.9) is then replaced by

$$\vec{\phi}_g = \mathbf{W}_g \vec{Q}_g^* - [\mathbf{I} + \mathbf{W}_g \Sigma_{s0,g \leftarrow g}] d_g(B) B^2 \gamma \mathbf{P}_{iS,g} \quad (3.15)$$

where  $\mathbf{P}_{iS,g} = \{P_{iS,g} ; i = 1, I\}$  is the array of escape probabilities in the open geometry and where

$$\gamma = \frac{\sum_j V_j \phi_{j,g}}{\sum_j V_j \phi_{j,g} P_{jS,g}} \quad (3.16)$$

ECCO

keyword used to perform an ECCO-type leakage calculation taking into account isotropic streaming effects. This method introduces an heterogeneous buckling contribution as a group dependent correction to the source term.<sup>[69,70]</sup> It is then necessary to set the keyword ECCO in module ASM: (see Section 3.5.1). In the  $P_1$  non-consistent case, Eq. (3.9) is then replaced by

$$\vec{\varphi}_g = \mathbf{W}_g \left( \vec{Q}_g^* - B^2 \frac{i\vec{J}_g}{B} \right) \quad (3.17)$$

$$\frac{i\vec{J}_g}{B} = \mathbf{X}_g \left[ \frac{1}{3} \vec{\varphi}_g + \sum_{h \neq g} \Sigma_{s1,g \leftarrow h} \frac{i\vec{J}_h}{B} \right] \quad (3.18)$$

where  $i\vec{J}_{j,g}/B$  is the multigroup fundamental current,  $\Sigma_{s1,g \leftarrow h} = \text{diag}\{\Sigma_{s1,i,g \leftarrow h} ; \forall i\}$  and where

$$\mathbf{X}_g = [\mathbf{I} - \mathbf{p}_g \Sigma_{s1,g \leftarrow g}]^{-1} \mathbf{p}_g \quad (3.19)$$

HETE

keyword used to perform a TIBÈRE-type leakage calculation taking into account anisotropic streaming effects. This method introduces an heterogeneous buckling contribution as a group dependent correction to the source term.<sup>[71,72]</sup> The heterogeneous buckling contribution is introduced in the  $B_n$  model using directional collision probabilities (PIJK method). It is then necessary to set the keyword PIJK in module ASM: (see Section 3.5.1).

G

keyword used to specify that the buckling search will assume all directional buckling to be identical (floating default option).

R

keyword used to specify that a radial buckling search will be considered assuming an imposed  $z$ -direction buckling.

Z

keyword used to specify that a  $z$ -direction buckling search will be considered assuming an imposed  $x$ -direction and  $y$ -direction buckling.

X

keyword used to specify that a  $x$ -direction buckling search will be considered assuming an imposed  $y$ -direction and  $z$ -direction buckling.

Y

keyword used to specify that a  $y$ -direction buckling search will be considered assuming an imposed  $x$ -direction and  $z$ -direction buckling.

BUCK

keyword used to specify the initial (for a buckling eigenvalue problem) or fixed (for a effective multiplication constant eigenvalue problem) buckling.

G

keyword used to specify that the buckling in the  $x$ -direction,  $y$ -direction and  $z$ -direction are to be initialized to  $valb2/3$  (floating default).

|          |  |
|----------|--|
| R        | keyword used to specify that the buckling in the $x$ -direction, and $y$ -direction are to be initialized to $valbr2/2$ .  |
| Z        | keyword used to specify that the buckling in the $z$ -direction, is to be initialized to $valbz2$ .  |
| X        | keyword used to specify that the buckling in the $x$ -direction, is to be initialized to $valbx2$ .  |
| Y        | keyword used to specify that the buckling in the $y$ -direction, is to be initialized to $valby2$ .  |
| $valb2$  | value of the fixed or initial total buckling in $cm^{-2}$ . The floating default value is $valb2 = valbx2 + valby2 + valbz2.$  |
| $valbr2$ | value of the fixed or initial radial buckling in $cm^{-2}$ . The floating default value is $valbr2 = valbx2 + valby2.$   |
| $valbz2$ | value of the fixed or initial $z$ -direction buckling in $cm^{-2}$ . The floating default value is $valbz2=0.0\ cm^{-2}$ . If $valb2$ is specified then $valbz2=valb2/3$ .   |
| $valbx2$ | value of the fixed or initial $x$ -direction buckling in $cm^{-2}$ . The floating default value is $valbx2=0.0\ cm^{-2}$ . If $valb2$ is specified then $valbx2=valb2/3$ . If $valbr2$ is specified then $valbx2=valbr2/2$ .   |
| $valby2$ | value of the fixed or initial $y$ -direction buckling in $cm^{-2}$ . The floating default value is $valby2=0.0\ cm^{-2}$ . If $valb2$ is specified then $valby2=valb2/3$ . If $valbr2$ is specified then $valby2=valbr2/2$ .   |
| KEFF     | keyword used to specify the fixed (for a buckling eigenvalue problem) effective multiplication constant.   |
| $valk$   | value of the fixed effective multiplication constant. The fixed default value is $valk=1.0$ .  |
| IDEM     | keyword used to specify that the initial (for a buckling eigenvalue problem) or fixed (for a effective multiplication constant eigenvalue problem) buckling is to be read from the data structure <i>LIBNAM</i> .  |
| MERG     | keyword to specify leakage zones. A leakage zone is a set of material mixtures where the diffusion coefficient is forced to be uniform in each energy group. Using an heterogeneous leakage model is incompatible with options PNLR and PNL. By default, an homogeneous leakage model with option SIGS is imposed where the leakage coefficients are all equal to the same value in each energy group. |
| $imergl$ | array of homogenized leakage zone indices to which are associated the material mixtures. $nbmix$ is the total number of material mixtures.   |

### 3.7 The EDI: module

The EDI: module supplies the main editing options to DRAGON. It can be use to compute the reaction rates, average and condensed cross sections to store this information on a file for further use. The calling specifications are:

Table 44: Structure (EDI:)

```
EDINAM := EDI: [ EDINAM ] LIBNAM [ TRKNAM FLUNAM ]
             [ REFGEO [ MACROGEO ] ] [ REFPIJ ] [ SURFIL ] :: (descedi)
```

where

|                 |   |
|-----------------|---|
| <i>EDINAM</i>   | <b>character*12</b> name of the EDITION data structure (L_EDIT signature) where the edition results will be stored.   |
| <i>LIBNAM</i>   | <b>character*12</b> name of the read-only MACROLIB or MICROLIB data structure (L_MACROLIB or L_LIBRARY signature) that contains the macroscopic cross sections (see Sections 3.1 and 3.2).  |
| <i>TRKNAM</i>   | <b>character*12</b> name of the read-only TRACKING data structure (L_TRACK signature) containing the tracking (see Section 3.4). <b>Note:</b> If data structures <i>TRKNAM</i> and <i>FLUNAM</i> are not given, a flux is recovered from the MACROLIB present in <i>LIBNAM</i> and used to perform the editions.  |
| <i>FLUNAM</i>   | <b>character*12</b> name of the read-only FLUXUNK data structure (L_FLUX signature) containing a transport solution (see Section 3.6).  |
| <i>REFGEO</i>   | <b>character*12</b> optional name of the read-only reference GEOMETRY data structure (L_GEOM signature) that was used for the original flux calculation (see Section 3.3).  |
| <i>MACROGEO</i> | <b>character*12</b> optional name of the read-only macro-GEOMETRY data structure (L_GEOM signature) that is saved in <i>EDINAM</i> and can be used in the homogenization process or in the SPH equivalence procedure. In some cases the module EDI: can automatically build a macro-geometry, however it is always possible to specify explicitly the macro-geometry to be saved in <i>EDINAM</i> . |
| <i>REFPIJ</i>   | <b>character*12</b> optional name of the read-only ASMPIJ data structure (L_PIJ signature) that was used for the reference flux calculation (see Section 3.5). Compulsory if keyword ALBS is used in Section 3.7.1.   |
| <i>SURFIL</i>   | <b>character*12</b> name of the read-only SALOME-formatted sequential ASCII file used to store the surfacic elements of the geometry. This file is required if and only if the keyword G2S is set in data structure (descedi).  |
| (descedi)       | structure containing the input data to this module (see Section 3.7.1).   |

## 3.7.1 Data input for module EDI:

Table 45: Structure (**descedi**)

```

[ EDIT iprint ]
[ UPS ]
[ MERG { NONE | COMP | GEO | HMIX |
      G2S nhom [[ RECT xm xp ym yp ]] [[ TRIA x1 y1 x2 y2 x3 y3 ]] [ REMIX (imix2(ii),ii=1,nhom) ] |
      CELL [ { SYBIL | EXCELL | NXT | DEFAULT | UNFOLD } ] [ REMIX (imix2(ii),ii=1,nbmix2) ] |
      REGI (iregm(ii),ii=1,nregio) |
      MIX [ (imixm(ii),ii=1,nbmix) ] } ]
[ TAKE {
      REGI (iregt(ii),ii=1,nregio) |
      MIX (imixt(ii),ii=1,nbmix) } ]
[ { POW | P1W_L | P1W_TO | PNW_SP } ]
[ EDI_CURR ] [ GOLVER ]
[ COND [ { NONE | ( icond(ii), ii=1,ngcond) | ( energy(ii), ii=1,ngcond) } ] ]
[ MICR [ ALLX ] [ ISOTXS [ ASCII ] ] { ALL | RES | nis (HISO(i),i=1,nis) }
      [ REAC nreac (HREAC(i),i=1,nreac) ] ]
[ ACTI [ ISOTXS [ ASCII ] ] { NONE | (imixa(ii),ii=1,nbmix) } ]
[ SAVE [ ON { DIRN | idirn } ] ]
[ PERT ]
[ STAT { ALL | RATE | FLUX | DELS } [ REFE { DIRO | idiro } ] ]
[ NOHF ] [ NBAL ]
[ MAXR maxpts ]
[ { DIRE | PROD } ]
[ MGEO MACGEO ]
[ { NADF | ALBS | JOUT | ADFM |
      [[ ADF [ * ] TYPE { REGI (ireg(ii),ii=1,iimax) ENDR | MIX (imix(ii),ii=1,iimax) ENDM } ] ] } ]
[ LEAK b2 ]

```

where

EDIT keyword used to modify the print level *iprint*.

*iprint* index used to control the printing of this module. The *iprint* parameter is important for adjusting the amount of data that is printed by this calculation step:

- *iprint*=0 results in no output;
- *iprint*=1 results in the average and integrated fluxes being printed (floating default);
- *iprint*=2 results in the reaction rates being printed;
- *iprint*=3 is identical to the previous option, but the condensed and/or homogenized vectorial cross sections are also printed;
- *iprint*=4 is identical to the previous option, but the condensed and/or homogenized transfer cross sections are also printed.

UPS keyword to specify that the reaction rates and the condensed and/or homogenized cross sections are corrected so as to eliminate up-scattering. This option is useful for



reactor analysis codes which cannot take into account such cross sections. Scattering ( $\sigma_{s,h\leftarrow g}$ ), diffusion ( $\sigma_{s,g}$ ) and total ( $\sigma_g$ ) cross sections are corrected as:

$$\tilde{\sigma}_{s,h\leftarrow g} = \begin{cases} 0 & \text{if } h < g \\ \sigma_{s,g\leftarrow g} & \text{if } h = g \\ \sigma_{s,h\leftarrow g} - \sigma_{s,g\leftarrow h} \frac{\phi_h}{\phi_g} & \text{if } h > g \end{cases}$$

$$\tilde{\sigma}_{s,g} = \sum_{h=1}^G \tilde{\sigma}_{s,h\leftarrow g} = \sigma_{s,g} - \sum_{h=1}^{g-1} \sigma_{s,h\leftarrow g} - \sum_{h=g+1}^G \sigma_{s,g\leftarrow h} \frac{\phi_h}{\phi_g}$$

$$\tilde{\sigma}_g = \sigma_g - \sum_{h=1}^{g-1} \sigma_{s,h\leftarrow g} - \sum_{h=g+1}^G \sigma_{s,g\leftarrow h} \frac{\phi_h}{\phi_g}.$$

|              |  |
|--------------|--|
| NONE         | keyword to deactivate the homogeneization or the condensation.   |
| MERG         | keyword to specify that the neutron flux is to be homogenized over specified regions or mixtures.  |
| REGI         | keyword to specify that the homogenization of the neutron flux will take place over the following regions. Here $nregio \leq maxreg$ with $maxreg$ the maximum number of regions for which solutions were obtained.  |
| <i>iregm</i> | array of homogenized region numbers to which are associated the old regions. In the editing routines a value of <i>iregm</i> =0 allows the corresponding region to be neglected.   |
| MIX          | keyword to specify that the homogenization of the neutron flux will take place over the following mixtures. Here we must have $nbmix \leq maxmix$ where $maxmix$ is the maximum number of mixtures in the macroscopic cross section library.   |
| <i>imixm</i> | array of homogenized region numbers to which are associated the material mixtures. In the editing routines a value of <i>imixm</i> =0 allows the corresponding isotopic mixtures to be neglected. For a mixture in this library which is not used in the geometry one should insert a value of 0 for the new region number associated with this mixture. This option is also useful to homogenize the cross-section data of the second-level mixtures by combining the first-level mixtures in a two-level computational scheme for a PWR assembly. By default, if MIX is set and <i>imixm</i> is not set, <i>imixm</i> ( <i>ii</i> )= <i>ii</i> is assumed. |
| COMP         | keyword to specify that the a complete homogenization is to take place.  |
| GEO          | keyword to specify that a geometry equivalence procedure (equigeom) is to be used. Merging indices are automatically computed by comparing the reference geometry <i>RE-FGEO</i> with the macro-geometry <i>MACROGEO</i> . This capability is limited to EXCELL-type reference geometries.   |
| G2S          | keyword to specify that the homogenization will be based on the geometry definition available in the surfacic file <i>SURFIL</i> .   |
| <i>nhom</i>  | number of homogeneous nodes to be defined using RECT and/or TRIA data structures. Many homogeneous mixtures can be defined by repeating the RECT and/or TRIA data structures.  |
| RECT         | keyword to specify a unique homogeneous mixture based on a rectangular node.   |
| <i>xm</i>    | lower limit of the homogeneous node along X-axis.  |
| <i>xp</i>    | upper limit of the homogeneous node along X-axis.  |
| <i>ym</i>    | lower limit of the homogeneous node along Y-axis.  |
| <i>yp</i>    | upper limit of the homogeneous node along Y-axis.  |

|              |   |
|--------------|---|
| TRIA         | keyword to specify a unique homogeneous mixture based on a triangular node.   |
| <i>x1</i>    | X-coordinate of the first corner.   |
| <i>y1</i>    | Y-coordinate of the first corner.   |
| <i>x2</i>    | X-coordinate of the second corner.  |
| <i>y2</i>    | Y-coordinate of the second corner.  |
| <i>x3</i>    | X-coordinate of the third corner.   |
| <i>y3</i>    | Y-coordinate of the third corner.   |
| HMIX         | keyword to specify that the homogenization region will be selected using the information provided by the HMIX option in the GEO: module (see Section 3.3.4). In this case, all the regions associated with a virtual homogenization mixture will be homogenized. If the virtual homogenization mixtures were not defined in the geometry, the real mixtures are used instead (see MIX keyword in Section 3.3.4). This option is valid only for NXT: based TRACKING data structure (this option uses the information stored on the reference TRKNAM data structure). |
| CELL         | keyword to specify that the a cell-by-cell homogenization (with or without SPH equivalence) is to take place. The macro-geometry and the merging indices are automatically computed and the macro-geometry named MACRO-GEOM is created on the root directory of EDINAM. This capability is limited to reference geometries previously tracked by EURYDICE (see Section 3.4.1) or NXT (see Section 3.4.3).   |
| SYBIL        | the macro-geometry produced by CELL is tracked by SYBILT: module.   |
| EXCELL       | the macro-geometry produced by CELL is tracked by EXCELT: module.   |
| NXT          | the macro-geometry produced by CELL is tracked by NXT: module.  |
| DEFAULT      | the macro-geometry produced by CELL is tracked by another module (default option).  |
| UNFOLD       | the macro-geometry produced by CELL is unfolded and tracked with the DEFAULT option. This option is useful with fine power reconstruction techniques.   |
| REMIX        | the homogenization produced by option MERG G2S or MERG CELL (cell-by-cell) is further homogenized according to <i>imix2</i> indices. This option is useful to integrate the assembly gap into the boundary cells. By default, one homogenized region is created for each region of the macro-geometry.  |
| <i>imix2</i> | array of rehomogenized region numbers to which are associated the regions indices created <i>after</i> the MERG G2S or MERG CELL homogenization was performed. In the editing routines a value of <i>imix2</i> =0 allows the corresponding region to be neglected. Here, <i>nbmix2</i> is equal to the number of mixtures in the geometry before the REMIX operation is performed (equal to the number of cells in the macro-geometry if MERG CELL was set).  |
| TAKE         | keyword to specify that the neutron flux is to be edited over specified regions or mixtures.  |
| REGI         | keyword to specify that the editing of the neutron flux will take place over the following regions. Here $n_{regio} \leq maxreg$ with <i>maxreg</i> the maximum number of regions for which solutions were obtained.  |
| <i>iregt</i> | regions where the editing will take place. The new region numbers associated with these editing regions are numbered sequentially.  |

MIX keyword to specify that the editing of the neutron flux will take place over the following mixtures. Here we must have  $\text{nbmix} \leq \text{maxmix}$  where *maxmix* is the maximum number of mixtures in the macroscopic cross section library.

*imixt* mixtures where the editing will take place. Each mixture set here must exist in the reference geometry.

POW keyword to specify that the  $P_\ell$ ,  $\ell \geq 1$  information is to be homogenized and condensed using the scalar flux. This is the default option.

P1W\_L keyword to specify that the  $P_\ell$ ,  $\ell \geq 1$  information is to be homogenized and condensed using a current recovered from a consistent  $P_1$  or from a consistent heterogeneous  $B_1$  model.

P1W\_TO keyword to specify that the  $P_\ell$ ,  $\ell \geq 1$  information is to be homogenized and condensed using the Todorova flux<sup>[119]</sup>, defined as

$$\phi_1(\mathbf{r}, E) = \frac{\phi(\mathbf{r}, E)}{\Sigma_i(E) - \Sigma_{s1,i}(E)}$$

where  $\Sigma_i(E)$  and  $\Sigma_{s1,i}(E)$  are the macroscopic total and  $P_1$  scattering cross sections in the mixture  $i$  containing the point  $\mathbf{r}$ . This option is not recommended.

PNW\_SP keyword to specify that the  $P_\ell$ ,  $\ell \geq 1$  information is to be homogenized and condensed using a weighting spectra based on the APOLLO3 averaging formula<sup>[120]</sup>, defined as

$$\phi_\ell(\mathbf{r}, E) = \frac{\sum_{m=-\ell}^{\ell} \phi_\ell^m(\mathbf{r}, E) \langle \phi_\ell^m \rangle_{G,M}}{\sum_{m=-\ell}^{\ell} \langle \phi_\ell^m \rangle_{G,M}}$$

where  $\phi_\ell^m(\mathbf{r}, E)$  are the spherical harmonic  $\ell$ -th moment of the flux with  $E \in G$  and  $\mathbf{r} \in M$ . Here,  $G$  is the condensed macrogroup and  $M$  is the homogenized mixture.

EDI\_CURR keyword to specify the generation of integrated net currents (homogenized and condensed) in the macrolib along each axis. This option is only provided with SN and MOC discretizations. By default, only integrated fluxes are generated.

GOLVER keyword to specify the use of the Golfier-Vergain diffusion coefficient formula. This formula is written

$$D_{i,g} = \frac{\alpha_g}{3\Sigma_{\text{tr},i,g}}$$

with the Golfier-Vergain factors  $\alpha_g$  defined as

$$\alpha_g = \frac{\sum_i \int_{u_{g-1}}^{u_g} du \frac{\phi_i(u)}{(\Sigma_i(u) - \Sigma_{s1,i}(u))}}{\sum_i \frac{\phi_{i,g}}{\Sigma_{\text{tr},i,g}}}$$

and where the multigroup transport cross sections are defined as

$$\Sigma_{\text{tr},i,g} = \frac{\int_{u_{g-1}}^{u_g} du (\Sigma(u) - \Sigma_{s1,i}(u)) \phi_i(u)}{\int_{u_{g-1}}^{u_g} du \phi_i(u)}.$$

By default, the diffusion coefficients are obtained by condensation of the fine-group leakage coefficients  $d_i(u)$ :

$$D_{i,g} = \frac{\int_{u_{g-1}}^{u_g} du d_i(u) \phi_i(u)}{\int_{u_{g-1}}^{u_g} du \phi_i(u)}.$$

|               |   |
|---------------|---|
| COND          | keyword to specify that a group condensation of the flux is to be performed.  |
| <i>icond</i>  | array of increasing energy group limits that will be associated with each of the <i>ngcond</i> condensed groups. The final value of <i>icond</i> will automatically be set to <i>ngroup</i> while the values of <i>icond</i> > <i>ngroup</i> will be dropped from the condensation. We must have <i>ngcond</i> ≤ <i>ngroup</i> . By default, if COND is set and <i>icond</i> is not set, all energy groups are condensed together.  |
| <i>energy</i> | array of decreasing energy limits (in eV) that will be associated with each of the <i>ngcond</i> condensed groups. We must have <i>ngcond</i> ≤ <i>ngroup</i> + 1. Note that if an energy limit is located between two energy groups, the condensation group will include this associated energy group. In the case where two energy limits fall within the same energy group the lowest energy will be dropped. Finally the maximum and minimum energy limits can be skipped since they will be taken automatically from the information available in the library. |
| MICR          | keyword to specify that the condensation and homogenization procedure will be used to associate microscopic cross sections to the isotopes present in the homogenized regions. The macroscopic cross sections and the diffusion coefficients are weighted by the multigroup fluxes appearing in the regions where the isotopes are present. The resulting nuclear properties are saved on <i>EDINAM</i> when the SAVE keyword is present.   |
| ALLX          | keyword used to register the region number of each isotope before merging, in the embedded library. The homogeneized information is therefore registered for each isotope in the merging region, as depicted by the formulas below. This procedure is useful to produce particular databases, in order to perform micro-depletion calculations in diffusion with DONJON.  |
| ALL           | keyword to specify that all the isotopes present in the homogenized region are to be kept individual and processed.   |
| RES           | keyword to specify that all the isotopes present in the homogenized region will be merged as a single residual isotope.   |
| <i>nis</i>    | number of isotopes present in the homogenized region to be processed.   |
| <i>HISO</i>   | array of <b>character*8</b> isotopes alias names to be processed.   |
| REAC          | keyword to specify the reaction names to be included in the output microlib. By default, all available reactions are included in the output microlib.   |
| <i>nreac</i>  | number of reactions to be included in the output microlib.  |
| <i>HREAC</i>  | array of <b>character*8</b> reaction names to be included in the output microlib.   |
| ACTI          | keyword to specify that microscopic activation data will be edited for the isotopes associated with the specified mixture. This information correspond to the microscopic cross section associated with each isotope in a given macro-group and macro-region assuming a concentration for this isotope of $1.0 \times cm^{-3}$ in each region. This keyword is followed by <i>nacti</i> material mixture indices, where <i>nacti</i> ≤ <i>maxmix</i> .  |
| NONE          | keyword to specify that no isotope present in the homogenized region is to be used as activation data.  |
| <i>imixa</i>  | array of material mixture indices which contains the isotopes for which activation data is to be generated. <i>nmix</i> ≤ <i>maxmix</i> . Even mixture not used in the geometry can be considered here.   |

|        |  |
|--------|--|
| ISOTXS | keyword to specify that the set of microscopic cross section generated by the MICR and ACTI command will also be saved on a microscopic group neutron cross section library in the ISOTXS-IV format. This will generate a file for each final region specified by the TAKE or MERG keyword, numbered consecutively (IFILE). The name of the file (NISOTXS) is built using the command<br><br>WRITE(NISOTXS,'(A6,I6.6)') 'ISOTXS',IFILE |
| ASCII  | keyword to specify that the ISOTXS file is created in ascii format. By default, it is created in binary format.  |
| SAVE   | keyword to specify that the fluxes, the macroscopic and microscopic cross sections and the volumes corresponding to homogenized regions are to be saved on EDINAM. A MACROLIB is store on a subdirectory of EDITION.   |
| ON     | keyword to specify on which directory of EDINAM this information is to be stored.  |
| DIRN   | name of the directory on which the above information is to be stored.  |
| idirn  | number associated with a directory of EDINAM on which the above information is to be stored. To each number idirn is associated a directory name CDIRN='REF-CASE'//CN where CN is a character*4 variable defined by WRITE(CN,'(I4)') idirn.  |
| PERT   | keyword to specify that first order perturbations for the microscopic cross sections are to be saved on EDINAM.  |
| STAT   | keyword to specify that a comparison between the current and a reference set of reaction rates and/or integrated fluxes is to be performed.  |
| ALL    | keyword to specify that the relative differences in the reaction rates and the integrated fluxes are to be printed.  |
| RATE   | keyword to specify that the relative differences in the reaction rates are to be printed.  |
| FLUX   | keyword to specify that the relative differences in the integrated fluxes are to be printed.   |
| DELS   | keyword to specify that the absolute differences in the macroscopic cross section are to be printed.   |
| REFE   | keyword to specify the directory of EDINAM where the reference data requires for the comparison is stored. When this keyword is absent, the last reaction rates and integrated fluxes saved on EDINAM are used.  |
| DIRO   | name of the directory from which the reference information is taken.   |
| idiro  | number associated with an directory of EDINAM on which the reference information is stored. To each number idirn is associated a the directory CDIRN='REF-CASE'//CN where CN is a character*4 variable defined by WRITE(CN,'(I4)') idirn.  |
| NOHF   | keyword to suppress the calculation and edition of the H-factors (sum of all the cross sections producing energy times the energy produced by each reaction). Note that this calculation may be time-consuming. By default, the H-factors are computed and edited if keyword DEPL and associated data is set in module LIB:.   |
| NBAL   | keyword to specify the editing of the four factors computed from a group balance. In this case, the user must specify explicitly a three group condensation.   |
| MAXR   | keyword to specify the number of components in region-related dynamically allocated arrays. If the default value is not sufficient, an error message is issued.  |

|               |  |
|---------------|--|
| <i>maxpts</i> | user-defined maximum number of components.   |
| DIRE          | use the direct flux to perform homogenization or/and condensation (default value).   |
| PROD          | use the product of the direct and adjoint flux to perform homogenization or/and condensation. This option is used only in specialized applications such as in the CLIO perturbative analysis formula. <sup>[118]</sup> The homogenization and condensation equations are presented in Sect. 3.7.3. <b>Note:</b> The <i>FLUNAM</i> object must contain both an adjoint and a direct flux solution.  |
| MGEO          | keyword to define the name of the macro-geometry, which must appear among the RHS. The macro-geometry is recovered automatically by interface modules such as <i>COMPO</i> : (see Section 3.13) or manually by a CLE-2000 statement such as<br><br><pre>GEONAM := EDINAM :: STEP UP 'MACRO-GEOM' ;</pre> <p>where <i>GEONAM</i> and <i>EDINAM</i> are <i>L_GEO</i> and <i>L_EDIT</i> LCM objects, respectively.</p>  |
| <i>MACGEO</i> | character*12 name of the macro-geometry.   |
| NADF          | keyword to deactivate boundary editions.   |
| ALBS          | keyword to specify that the boundary flux is to be obtained from relation $\phi_{\text{surf}} = 4J_{\text{out}}/S$ where $J_{\text{out}}$ is the outgoing interface current. The albedo of the geometry are to be taken into account in the complete homogenization process. Thus the <i>MERG</i> and <i>COMP</i> options must be specified. The boundary fluxes are obtained from a calculation using the collision probabilities. This option requires a geometry with <i>VOID</i> (see Section 3.3.2) external boundary conditions to be closed using <i>ALBS</i> in module <i>ASM</i> : (see Section 3.5.1). <sup>[77]</sup>   |
| JOUT          | keyword to recover multigroup boundary current information ( $J_{\text{out}}$ and $J_{\text{in}}$ ). This keyword is only compatible with <i>MCCGT</i> : or <i>SYBILT</i> : trackings and if keyword <i>ARM</i> is set in module <i>ASM</i> : (see Section 3.5.1). The outgoing/ingoing interface currents are recovered by direct homogenization and condensation of the flux unknown components corresponding to external boundary and used with the current iteration method in <i>Eurydice</i> or from a <i>MOC</i> calculation. The boundary flux required by the <i>SPH</i> method is to be obtained from relation $\phi_{\text{surf}} = 4J_{\text{out}}/S$ where $J_{\text{out}}$ is the outgoing interface current. The net boundary current is to be obtained from relation $J_{\text{net}} = J_{\text{out}} - J_{\text{in}}$ . |
| ADFM          | keyword to specify that the ADF information is recovered from <i>macrolib</i> in RHS object <i>LIBNAM</i> . ADF information can be defined as explained in Sect. 3.1.2 of module <i>MAC</i> : and recovered in module <i>EDI</i> : for further processing.   |
| ADF           | keyword to specify that boundary editions are required. Averaged fluxes are computed over boundary regions.  |
| *             | keyword to specify that boundary fluxes are divided by average assembly fluxes so as to produce <i>assembly discontinuity factors</i> (ADF). By default, boundary fluxes are recovered and saved in the boundary edit without further treatment.   |
| <i>TYPE</i>   | character*8 name of the boundary edit corresponding to regions <i>ireg</i> or mixtures <i>imix</i> . Any user-defined name can be used, but some standard names are recognized by module <i>SPH</i> (see Section 3.9.2). Standard names are: = <i>FD_C</i> : corner flux edition; = <i>FD_B</i> : surface (assembly gap) flux edition; = <i>FD_H</i> : row flux edition. These are the first row of surrounding cells in the assembly.   |
| <i>ireg</i>   | index of a region of the reference geometry belonging to boundary edition.   |
| <i>imix</i>   | index of a material mixture of the reference geometry belonging to boundary edition.   |

|      |   |
|------|---|
| LEAK | keyword used to introduce leakage in the embedded MACROLIB. This option should only be used for non-regression tests. The MICROLIB is not modified. |
| b2   | the imposed buckling corresponding to the leakage.  |

### 3.7.2 Homogenization and condensation with the flux

The cross sections are homogenized over macro-volumes  $V_{\text{merg}}$  and condensed over macro groups  $E_{\text{merg}}$ . We also use  $V_i$  to identify the subset of  $V_{\text{merg}}$  where the isotope  $i$  is defined. The module EDI: produces the following homogenized/condensed information:

**integrated volume:**

$$\bar{V} = \int_{V_{\text{merg}}} dV$$

**macroscopic cross section of type  $x$ :**

$$\bar{\Sigma}_x = \frac{\int_{V_{\text{merg}}} dV \int_{E_{\text{merg}}} dE \Sigma_x(\mathbf{r}, E) \phi(\mathbf{r}, E)}{\int_{V_{\text{merg}}} dV \int_{E_{\text{merg}}} dE \phi(\mathbf{r}, E)}$$

**number density for isotope  $i$ :**

$$\bar{N}_i = \frac{1}{\bar{V}} \int_{V_i} dV N_i(\mathbf{r})$$

where  $N_i(\mathbf{r})$  is the space-dependent number density of isotope  $i$ .

**neutron flux:**

$$\bar{\phi} = \frac{1}{\bar{V}} \int_{V_{\text{merg}}} dV \int_{E_{\text{merg}}} dE \phi(\mathbf{r}, E)$$

**microscopic cross section of type  $x$  for isotope  $i$ :**

$$\begin{aligned} \bar{\sigma}_{x,i} &= \frac{1}{\bar{N}_i} \frac{\int_{V_i} dV \int_{E_{\text{merg}}} dE N_i(\mathbf{r}) \sigma_{x,i}(\mathbf{r}, E) \phi(\mathbf{r}, E)}{\int_{V_{\text{merg}}} dV \int_{E_{\text{merg}}} dE \phi(\mathbf{r}, E)} \\ &= \frac{1}{\bar{N}_i \bar{\phi} \bar{V}} \int_{V_i} dV \int_{E_{\text{merg}}} dE N_i(\mathbf{r}) \sigma_{x,i}(\mathbf{r}, E) \phi(\mathbf{r}, E) \quad . \end{aligned}$$

### 3.7.3 Homogenization and condensation with the flux and adjoint flux

If the PROD keyword is set in data structure 3.7.1, the adjoint flux is introduced as a weighting function in the homogenization and condensation formulas. In this case, the module EDI: produces the following homogenized/condensed information:

**adjoint neutron flux:**

$$\bar{\phi}^* = \frac{1}{\bar{\phi} \bar{V}} \int_{V_{\text{merg}}} dV \int_{E_{\text{merg}}} dE \phi^*(\mathbf{r}, E) \phi(\mathbf{r}, E)$$

**microscopic transfer cross section for isotope  $i$ :**

$$\bar{\sigma}_{s,i} = \frac{1}{\bar{N}_i (\bar{\phi}^*)' \bar{\phi} \bar{V}} \int_{V_i} dV \int_{E'_{\text{merg}}} dE' \int_{E_{\text{merg}}} dE N_i(\mathbf{r}) \sigma_{s,i}(\mathbf{r}, E' \leftarrow E) \phi^*(\mathbf{r}, E') \phi(\mathbf{r}, E)$$

with

$$(\bar{\phi}^*)' = \frac{1}{(\bar{\phi})' \bar{V}} \int_{V_{\text{merg}}} dV \int_{E'_{\text{merg}}} dE' \phi^*(\mathbf{r}, E') \phi(\mathbf{r}, E')$$

**microscopic cross section of type  $x \neq f$  for isotope  $i$ :**

$$\bar{\sigma}_{x,i} = \frac{1}{N_i \bar{\phi} \bar{\phi}^* \bar{V}} \int_{V_i} dV \int_{E_{\text{merg}}} dE N_i(\mathbf{r}) \sigma_{x,i}(\mathbf{r}, E) \phi^*(\mathbf{r}, E) \phi(\mathbf{r}, E)$$

**microscopic  $\nu$  times fission cross section for isotope  $i$ :**

$$\bar{\nu}\bar{\sigma}_{f,i} = \frac{1}{N_i \bar{\phi} \bar{V}} \int_{V_i} dV \int_{E_{\text{merg}}} dE N_i(\mathbf{r}) \nu\sigma_{f,i}(\mathbf{r}, E) \phi(\mathbf{r}, E)$$

**fission spectra for isotope  $i$ :**

$$\bar{\chi}_i = \frac{1}{\bar{\mathcal{F}}_i \bar{\phi}^* \bar{V}} \int_{V_i} dV \int_{E_{\text{merg}}} dE \chi_i(\mathbf{r}, E) \mathcal{F}_i(\mathbf{r}) \phi^*(\mathbf{r}, E)$$

where  $\mathcal{F}_i(\mathbf{r})$  is the energy-integrated fission rate for isotope  $i$ , defined as

$$\mathcal{F}_i(\mathbf{r}) = \int_{\infty} dE N_i(\mathbf{r}) \nu\sigma_{f,i}(\mathbf{r}, E) \phi(\mathbf{r}, E)$$

and

$$\bar{\mathcal{F}}_i = \frac{1}{\bar{V}} \int_{V_i} dV \mathcal{F}_i(\mathbf{r}) .$$

Both the macrolib and microlib information is affected by the adjoint weighting. However, users should be advised that this operation may have some undesirable effects on the fission spectrum normalization. Its use must therefore be limited to specialized applications where the adjoint weighting is theoretically required. This is the case, for example, with the CLIO perturbative analysis method.<sup>[118]</sup>



### 3.8 The EVO: module

The EVO: module performs the burnup calculations. The depletion equations for the various isotope of the MICROLIB are solved using the burnup chains also present in the MICROLIB. Both in-core and out-of-core calculations can be considered. For in-core depletion calculations, one assumes linear flux variation over each irradiation period (time stage). The initial (and possibly final) flux distributions are recovered from previous FLU: calculations. In-core depletion can be performed at constant flux or constant power (expressed in MW/Tonne of initial heavy elements) but these values can undergo step variations from one time stage to another. All the information required for successive burnup calculation is stored on the PyLCM BURNUP data structure. Thus it is possible at any point in time to return to a previous time step and restart the calculations.

In each burnup mixture of the unit cell, the depletion of  $K$  isotopes over a time stage  $(t_0, t_f)$  follows the following equation:

$$\frac{dN_k}{dt} + N_k(t) \Lambda_k(t) = S_k(t) \quad ; \quad k = 1, K \quad (3.20)$$

with

$$\Lambda_k(t) = \lambda_k + \langle \sigma_{a,k}(t) \phi(t) \rangle, \quad (3.21)$$

$$S_k(t) = \sum_{l=1}^L Y_{kl} \langle \sigma_{f,l}(t) \phi(t) \rangle N_l(t) + \sum_{l=1}^K m_{kl}(t) N_l(t), \quad (3.22)$$

$$\langle \sigma_{x,l}(t) \phi(t) \rangle = \int_0^\infty \sigma_{x,l}(u) \phi(t, u) du \quad (3.23)$$

and

$$\sigma_{x,k}(t, u) \phi(t, u) = \sigma_{x,k}(t_0, u) \phi(t_0, u) + \frac{\sigma_{x,k}(t_f, u) \phi(t_f, u) - \sigma_{x,k}(t_0, u) \phi(t_0, u)}{t_f - t_0} (t - t_0) \quad (3.24)$$

where

- $K$  = number of depleting isotopes
- $L$  = number of fissile isotopes producing fission products
- $N_k(t)$  = time dependant number density for  $k$ -th isotope
- $\lambda_k$  = radioactive decay constant for  $k$ -th isotope
- $\sigma_{x,k}(t, u)$  = time and lethargy dependant microscopic cross section for nuclear reaction  $x$  on  $k$ -th isotope.  $x=a$ ,  $x=f$  and  $x=\gamma$  respectively stands for absorption, fission and radiative capture cross sections
- $\phi(t, u)$  = time and lethargy dependant neutron flux
- $Y_{kl}$  = fission yield for production of fission product  $k$  by fissile isotope  $l$
- $m_{kl}(t)$  = radioactive decay constant or  $\langle \sigma_{x,l}(t) \phi(t) \rangle$  term for production of isotope  $k$  by isotope  $l$ .

Depleting isotopes with  $\Lambda_k(t_0) [t_f - t_0] \geq \text{valexp}$  and  $\Lambda_k(t_f) [t_f - t_0] \geq \text{valexp}$  are considered to be at saturation. They are described by making  $\frac{dN_k}{dt} = 0$  in Eq. (3.20) to obtain

$$N_k(t) = \frac{S_k(t)}{\Lambda_k(t)} \quad ; \quad \text{if } k \text{ is at saturation.} \quad (3.25)$$

If the keyword SAT is set, beginning-of-stage and end-of-stage Dirac contributions are added to the previous equation:

$$N_k(t) = \frac{1}{\Lambda_k(t)} [a\delta(t - t_0) + S_k(t) + b\delta(t - t_f)] \quad ; \quad \text{if } k \text{ is at saturation} \quad (3.26)$$

where  $a$  and  $b$  are chosen in order to satisfy the time integral of Eq. (3.20):

$$N_k(t_f^+) - N_k(t_0^-) + \int_{t_0^-}^{t_f^+} N_k(t) \Lambda_k(t) dt = \int_{t_0^-}^{t_f^+} S_k(t) dt \quad (3.27)$$

It is numerically convenient to chose the following values of  $a$  and  $b$ :

$$a = N_k(t_0^-) - \frac{S_k(t_0^+)}{\Lambda_k(t_0^+)} \quad (3.28)$$

and

$$b = \frac{S_k(t_0^+)}{\Lambda_k(t_0^+)} - \frac{S_k(t_f^+)}{\Lambda_k(t_f^+)} \quad (3.29)$$

The numerical solution techniques used in the **EVO**: module are the following. Very short period isotopes are taken at saturation and are solved apart from non-saturating isotopes. If an isotope is taken at saturation, all its parent isotopes, other than fissiles isotopes, are also taken at saturation. Isotopes at saturation can produce daughter isotopes using decay *and/or* neutron-induced reactions.

The lumped depletion matrix system containing the non-saturating isotopes is solved using either a fifth order Cash-Karp algorithm or a fourth order Kaps-Rentrop algorithm<sup>[82]</sup>, taking care to perform all matrix operations in sparse matrix algebra. Matrices  $[m_{kl}(t_0)]$  and  $[m_{kl}(t_f)]$  are therefore represented in diagonal banded storage and kept apart from the yield matrix  $[Y_{kl}]$ . Every matrix multiplication or linear system solution is obtained via the LU algorithm.

The solution of burnup equations is affected by the flux normalization factors. **DRAGON** can perform out-of-core or in-core depletion with a choice between two normalization techniques:

1. Constant flux depletion. In this case, the lethargy integrated fluxes at beginning-of-stage and end-of-stage are set to a constant  $F$ :

$$\int_0^\infty \phi(t_0, u) du = \int_0^\infty \phi(t_f, u) du = F \quad (3.30)$$

2. Constant power depletion. In this case, the power released per initial heavy element at beginning-of-stage and end-of-stage are set to a constant  $W$ .

$$\begin{aligned} \sum_{k=1}^K [\kappa_{f,k} \langle \sigma_{f,k}(t_0) \phi(t_0) \rangle + \kappa_{\gamma,k} \langle \sigma_{\gamma,k}(t_0) \phi(t_0) \rangle] N_k(t_0) &= \\ \sum_{k=1}^K [\kappa_{f,k} \langle \sigma_{f,k}(t_f) \phi(t_f) \rangle + \kappa_{\gamma,k} \langle \sigma_{\gamma,k}(t_f) \phi(t_f) \rangle] N_k(t_f) &= C_0 W \end{aligned} \quad (3.31)$$

where

$$\begin{aligned} \kappa_{f,k} &= \text{energy (MeV) released per fission of the fissile isotope } k \\ \kappa_{\gamma,k} &= \text{energy (MeV) released per radiative capture of isotope } k \\ C_0 &= \text{conversion factor (MeV/MJ) multiplied by the mass of initial heavy elements} \\ &\quad \text{expressed in metric tonnes} \end{aligned}$$

The end-of-stage power is function of the number densities  $N_k(t_f)$ ; a few iterations will therefore be required before the end-of-stage power released can be set equal to the desired value. Note that there is no warranties that the power released keep its desired value at every time during the stage; only the beginning-of-stage and end-of-stage are set.

Whatever the normalisation technique used, DRAGON compute the exact burnup of the unit cell (in MW per tonne of initial heavy element) by adding an additional equation in the depletion system. This value is the local parameter that should be used to tabulate the output cross sections.

The general format of the data which is used to control the execution of the EVO: module is the following:

Table 46: Structure (EVO:)

```
BRNNAM MICNAM := EVO:
  [ BRNNAM ] { MICNAM | OLDMIC } [ { FLUNAM TRKNAM | POWNAM } ]
  :: (descevo)
```

where

|               |   |
|---------------|---|
| <i>BRNNAM</i> | <b>character*12</b> name of the BURNUP data structure that will contain the depletion history as modified by the depletion module. If <i>BRNNAM</i> appears on both LHS and RHS, it is updated; otherwise, it is created.   |
| <i>MICNAM</i> | <b>character*12</b> name of the MICROLIB containing the microscopic cross sections at save point <i>xts</i> . <i>MICNAM</i> is modified to include an embedded MACROLIB containing the updated macroscopic cross sections at set point <i>xtr</i> . If <i>MICNAM</i> appears on both LHS and RHS, it is updated; otherwise, the internal library <i>OLDMIC</i> is copied in <i>MICNAM</i> and <i>MICNAM</i> is updated. It is possible to assign different MICROLIB to different save points of the depletion calculation. In this case, the microscopic reaction rates will be linearly interpolated/extrapolated between points <i>xti</i> and <i>xtf</i> . |
| <i>OLDMIC</i> | <b>character*12</b> name of a read-only MICROLIB that is copied in <i>MICNAM</i> .  |
| <i>FLUNAM</i> | <b>character*12</b> name of a read-only FLUXUNK at save point <i>xts</i> . This information is used for in-core depletion cases. This information is not required for out-of-core depletion cases. Otherwise, it is mandatory   |
| <i>TRKNAM</i> | <b>character*12</b> name of a read-only TRACKING constructed for the depleting geometry and consistent with object <i>FLUNAM</i> .  |
| <i>POWNAM</i> | <b>character*12</b> name of a read-only POWER object (generated by DONJON) at save point <i>xts</i> . This information is used for micro-depletion cases.   |
| (descevo)     | structure containing the input data to this module (see Section 3.8.1).   |

For the in-core depletion cases, the tracking TRACKING data structure on which *FLUNAM* is based, is automatically recovered in read-only mode from the generalized driver dependencies.

### 3.8.1 Data input for module EVO:

Table 47: Structure (descevo)

```
[ EDIT iprint ]
```

continued on next page

Structure (**descevo**)

continued from last page

```
[ { SAVE xts { S | DAY | YEAR } { FLUX flux | POWR fpower | W/CC apower } | NOSA } ]
[ EPS1 valeps1 ] [ EPS2 valeps2 ] [ { EXPM valex | SATOFF } ]
[ H1 valh1 ] [ { RUNG | KAPS } ]
[ { TIXS | TDXS } ] [ { NOEX | EXTR } ] [ { NOGL | GLOB } ] [ { NSAT | SAT } ] [ { NODI | DIRA } ]
[ { FLUX_FLUX | FLUX_MAC | FLUX_POW } ] [ { CHAIN | PIFI } ]
[ DEPL { xti xtf | dxt } { S | DAY | YEAR } { COOL | FLUX flux | POWR fpower | W/CC apower | KEEP } ]
[ SET xtr { S | DAY | YEAR } ]
[ MIXB [[ mixbrn ]] ] [ MIXP [[ mixpwr ]] ]
[ PICK >> burnup << ]
;
```

where

- EDIT** keyword used to modify the print level *iprint*.
- iprint* index used to control the printing of the module. The amount of output produced by this tracking module will vary substantially depending on the print level specified.
- SAVE** keyword to specify that the current isotopic concentration and the microscopic reaction rates resulting from the last transport calculation will be normalized and stored on *BRNNAM* in a sub-directory corresponding to a specific time. By default this data is stored at a time corresponding to *xti*.
- NOSA** keyword to specify that the current isotopic concentration and the results of the last transport calculation will not be stored on *BRNNAM*. By default this data is stored at a time corresponding to *xti*.
- SET** keyword used to recover the isotopic concentration already stored on *BRNNAM* from a sub-directory corresponding to a specific time. By default this data is recovered from a time corresponding to *xtf*.
- DEPL** keyword to specify that a burnup calculation between an initial and a final time must be performed. In the case where the **SAVE** keyword is absent, the initial isotopic concentration will be stored on *BRNNAM* on a sub-directory corresponding to the initial time. If the **SET** keyword is absent, the isotopic concentration corresponding to the final burnup time will be used to update *MICNAM*.
- xti* initial time associated with the burnup calculation. The name of the sub-directory where this information is stored will be given by 'DEPL-DAT'//CNN where CNN is a **character\*4** variable defined by **WRITE(CNN, '(I4.4)')** INN where INN is an index associated with the time *xti*. The initial values are recovered from this sub-directory in *BRNNAM*.
- xtf* end of time for the burnup calculation. The results of the isotopic depletion calculations are stored in the tables associated with a sub-directory whose name is constructed in the same manner as the *xti* input.
- dxt* time interval for the burnup calculation. The initial time *xti* in this case is taken as the final time reached at the last depletion step. If this is the first depletion step, *xti* = 0.
- xts* time associated with the last transport calculation. The name of the sub-directory where this information is to be stored is constructed in the same manner as the for *xti* input. By default (fixed default) *xts*=*xti*.
- xtr* time associated with the next flux calculation. The name of the sub-directory where this information is to be stored is constructed in the same manner as for the *xti* input. By default (fixed default) *xtr*=*xtf*.

|                |   |
|----------------|---|
| S              | keyword to specify that the time is given in seconds.   |
| DAY            | keyword to specify that the time is given in days.  |
| YEAR           | keyword to specify that the time is given in years.   |
| COOL           | keyword to specify that a zero flux burnup calculation is to be performed.  |
| FLUX           | keyword to specify that a constant flux burnup calculation is to be performed.  |
| <i>flux</i>    | flux expressed in $cm^{-2}s^{-1}$ .   |
| POWR           | keyword to specify that a constant fuel power depletion calculation is to be performed. The energy released outside the fuel (e.g., by $(n,\gamma)$ reactions) is <i>not</i> taken into account in the flux normalization, unless the GLOB option is set.   |
| <i>fpower</i>  | fuel power expressed in $KW Kg^{-1} = MW tonne^{-1}$ .  |
| W/CC           | keyword to specify that a constant assembly power depletion calculation is to be performed. The energy released outside the fuel (e.g., by $(n,\gamma)$ reactions) is always taken into account in the flux normalization.  |
| <i>apower</i>  | assembly power density expressed in $W/cm^3$ (Power per unit assembly volume).  |
| KEEP           | keyword to specify that the flux is used without been normalized. This option is useful in cases where the flux was already normalized before the call to EVO: module.  |
| EPS1           | keyword to specify the tolerance used in the algorithm for the solution of the depletion equations.   |
| <i>valeps1</i> | the tolerance used in the algorithm for the solution of the depletion equations. The default value is $valeps1=1.0 \times 10^{-5}$ .  |
| EPS2           | keyword to specify the tolerance used in the search algorithm for a final fixed power (used if the POWR or W/CC option is activated).   |
| <i>valeps2</i> | the tolerance used in the search algorithm for a final fixed power. The default value is $valeps2=1.0 \times 10^{-4}$ .   |
| EXPM           | keyword to specify the selection criterion for non-fissile isotopes that are at saturation.   |
| <i>valexp</i>  | the isotopes for which $\lambda \times (xtf - xti) \geq valexp$ will be treated by a saturation approximation. Here, $\lambda$ is the sum of the radioactive decay constant and microscopic neutron absorption rate. The default value is $valexp=80.0$ . In order to remove the saturation approximation for all isotopes set <i>valexp</i> to a very large number such as $1.0 \times 10^5$ . On the other way, the saturation approximation can be set for a specific isotope by using the keyword SAT in Sect. 3.2.3 (module LIB:). |
| SATOFF         | keyword to remove the saturation approximation for all isotopes even if SAT keyword was set in Sect. 3.2.3 (module LIB:).   |
| H1             | keyword to specify an estimate of the relative width of the time step used in the solution of burnup equations.   |
| <i>valh1</i>   | relative width of the time step used in the solution of burnup equations. An initial time step of $\Delta_t = valh1 \times (xtf - xti)$ is used. This value is optimized dynamically by the program. The default value is $valh1=1.0 \times 10^{-4}$ .  |
| RUNG           | keyword to specify that the solution will be obtained using the 5 <sup>th</sup> order Cash-Karp algorithm.  |
| KAPS           | keyword to specify that the solution will be obtained using the 4 <sup>th</sup> order Kaps-Rentrop algorithm. This is the default value.  |

|               |   |
|---------------|---|
| TIXS          | keyword that specified that time independent cross sections will be used. This is the default option when no time dependent cross sections are provided.  |
| TDXS          | keyword that specified that time dependent cross sections will be used if available. This is the default option when time dependent cross sections are provided.  |
| NOEX          | keyword to suppress the linear extrapolation of the microscopic reaction rates in the solution of the burnup equations.   |
| EXTR          | keyword to perform a linear extrapolation of the microscopic reaction rates, using the available information preceding the initial time $x_{ti}$ . This is the default option.  |
| NOGL          | keyword to compute the burnup using the energy released in fuel only. This is the default option.   |
| GLOB          | keyword to compute the burnup using the energy released in the complete geometry. This option has an effect only in cases where some energy is released outside the fuel (e.g., due to $(n,\gamma)$ reactions). This option affects both the meaning of $f_{power}$ (given after the key-word POWR) and the value of the burnup, as computed by EVO:. |
| NSAT          | save the non-saturated initial number densities in the BURNUP object <i>BRNNAM</i> (default value)  |
| SAT           | save the saturated initial number densities in the BURNUP object <i>BRNNAM</i>  |
| NODI          | select Eq. (3.25) to compute the saturated number densities (default value)   |
| DIRA          | select Eq. (3.26) to compute the saturated number densities   |
| FLUX_FLUX     | recover the neutron flux from <i>FLUNAM</i> object (default option)   |
| FLUX_MAC      | recover the neutron flux from embedded macrolib present in <i>MICNAM</i> or <i>OLDMIC</i> object. This option is useful to deplete in cases where the neutron flux is obtained from a Monte Carlo calculation.  |
| FLUX_POW      | recover the neutron flux from the POWER object named <i>POWNAM</i> generated in DONJON. This option is useful in micro-depletion cases. The neutron flux recovered from <i>POWNAM</i> is generally normalized to the power of the full core. It is therefore recommended to use the KEEP option in DEPL data structure.                               |
| CHAIN         | recover the fission yield data from 'DEPL-CHAIN' directory of <i>MICNAM</i> or <i>OLDMIC</i> object (default option). With this option, the fission yield data is the same in all material mixtures.  |
| PIFI          | recover the fission yield data from 'PIFI' and 'PYIELD' records present in isotopic directories of <i>MICNAM</i> or <i>OLDMIC</i> object. With this option, the fission yield data is mixture-dependent. This option is useful in micro-depletion cases.  |
| MIXB          | keyword to select depleting material mixtures. By default, all mixtures with depleting isotopes are set as depleting.   |
| <i>mixbrn</i> | indices of depleting material mixtures.   |
| MIXP          | keyword to select material mixtures producing power. By default, <ul style="list-style-type: none"> <li>• if MIXB is not set, all mixtures with isotopes producing power are set as producing power</li> <li>• if MIXB is set, the same mixtures <i>mixbrn</i> are set as producing power.</li> </ul>   |
| <i>mixpwr</i> | indices of material mixtures producing power.   |
| PICK          | keyword used to recover the final burnup value (in MW-day/tonne) in a CLE-2000 variable.  |

*burnup*            **character\*12** CLE-2000 variable name in which the extracted burnup value will be placed.

### 3.8.2 Power normalization in EVO:

Flux-induced depletion is dependent of the flux or power normalization factor given after key-words **FLUX**, **POWR** or **W/CC**. The depletion steps, given after key-words **SAVE**, **DEPL** or **SET**, are set in time units. Traditionally, the power normalization factor is given in *MW tonne<sup>-1</sup>* and the depletion steps are given in *MWday tonne<sup>-1</sup>*. However, a confusion appear in cases where some energy is released outside the fuel (e.g., due to (n,γ) reactions).

The accepted rule and default option in **EVO**: is to compute the burnup steps in units of *MWday tonne<sup>-1</sup>* by considering only the energy released in fuel (and only the initial mass of the heavy elements present in fuel). However, it is also recommended to provide a normalization power taking into account the *total* energy released in the global geometry. The **GLOB** option can be use to change this rule and to use the energy released in the complete geometry to compute the burnup. However, this is not a common practice, as it implies a non-usual definition of the burnup. A more acceptable solution consists in setting the normalization power in power per unit volume of the complete geometry using the key-word **W/CC**. The value of *apower* can be computed from the linear power  $f_{\text{lin}}$  (expressed in *Mev s<sup>-1</sup> cm<sup>-1</sup>*) using:

$$apower = \frac{f_{\text{lin}} 1.60207 \times 10^{-13}}{V_{\text{assmb}}} \quad (3.32)$$

where  $V_{\text{assmb}}$  is the 2-D lumped volume of the assembly expressed in *cm<sup>2</sup>*.

The corresponding normalization factor  $f_{\text{burnup}}$  in *MW tonne<sup>-1</sup>* is given as

$$f_{\text{burnup}} = \frac{apower}{D_g F_{\text{power}}} \quad (3.33)$$

where  $D_g$  is the mass of heavy elements per unit volume of the complete geometry (*g cm<sup>-3</sup>*) and  $F_{\text{power}}$  is the ratio of the energy released in the complete geometry over the energy released in fuel. Numerical values of  $D_g$  and  $f_{\text{power}}$  are computed by **EVO**: when the parameter *iprint* is greater or equal to 2. The burnup  $B$  corresponding to an elapsed time  $\Delta t$  is therefore given as

$$B = f_{\text{burnup}} \Delta t \quad (3.34)$$

where  $B$  is expressed in *MWday tonne<sup>-1</sup>* and  $\Delta t$  is expressed in *day*.

The unit of the reaction rates depends on the normalization applied to the flux. This normalization takes place after the flux calculation, using the **EVO**: module. Here is an example:

```

INTEGER istep := 1 ;
REAL Tend := 0.0 ;
REAL Fuelpwr := 38.4 ; ! expressed in MW/tonne

BURN MICROLIB := EVO: MICROLIB FLUX TRACKN ::
  EDIT 0
  SAVE <<Tend>> DAY POWR <<Fuelpwr>>
;

```

where **BURN** is the burnup object, **MICROLIB** is the Microlib used to compute the flux, **FLUX** is the flux object and **TRACKN** is the tracking object used to compute the flux. After this call, the record 'FLUX-NORM' in **BURN** contains a unique real number, equal to the flux normalization factor. If **MICROLIB** is obtained using the **LIB**: module, the **DEPL** keyword with following data must be set (see Section 3.2.1). Unfortunately, the normalization factor is kept aside and is not applied to the flux present in object **FLUX**. In fact, only the advanced post-processing modules **COMPO**: (see Section 3.13) and **SAP**: (see Section 3.18) are making use of this normalization factor.

### 3.9 The SPH: module

The *superhomogénéisation* (SPH) equivalence technique is based on the calculation of a set of *equivalence factors*  $\{\mu_{m,k}, m \in C_m \text{ and } k \in M_k\}$ , where  $C_m$  and  $M_k$  is a macro region and a coarse energy group of a full-core or macro calculation (see Sect. 4.4 of Ref. 1). These equivalence factors are computed in such a way that a macro calculation made over  $C_m$  and  $M_k$  with a simplified transport operator leads to the same leakage and reaction rates as a reference calculation performed without homogenization and with a fine group discretization.

The SPH correction is applied differently, depending on the type of macro-calculation:

- In the case where the macro-calculation is done with the diffusion theory, neutron balance is satisfied if the SPH correction is applied as follows:

$$\nabla \cdot \mathbf{J}_g(\mathbf{r}) + \mu_g \Sigma_g(\mathbf{r}) \frac{\phi_g(\mathbf{r})}{\mu_g} = \frac{\chi_g}{k_{\text{eff}}} \sum_{h=1}^G \mu_h \nu \Sigma_{f,h}(\mathbf{r}) \frac{\phi_h(\mathbf{r})}{\mu_h} + \sum_{h=1}^G \mu_h \Sigma_{s0,g \leftarrow h}(\mathbf{r}) \frac{\phi_h(\mathbf{r})}{\mu_h} \quad (3.35)$$

and

$$\mathbf{J}_g(\mathbf{r}) = -\mu_g D_g(\mathbf{r}) \frac{\nabla \phi_g(\mathbf{r})}{\mu_g}. \quad (3.36)$$

In conclusion:

- Diffusion coefficients and all  $P_0$  cross sections (including the total cross section NTOTO) must be multiplied by  $\mu_g$ .
- Scattering matrix terms  $\Sigma_{s0,g \leftarrow h}(\mathbf{r})$  must be multiplied by  $\mu_h$ .
- Fluxes (such as NWT0 and FLUX-INTG) must be divided by  $\mu_g$ .
- In the case where the macro-calculation is done with the simplified  $P_n$  method, the neutron balance is satisfied if the SPH correction is applied on even parity equations as follows:<sup>[105]</sup>

$$\mu_g \Sigma_{0,g}(\mathbf{r}) \frac{\phi_{0,g}(\mathbf{r})}{\mu_g} + \nabla \cdot \phi_{1,g}(\mathbf{r}) = \frac{\chi_g}{k_{\text{eff}}} \sum_{h=1}^G \mu_h \nu \Sigma_{f,h}(\mathbf{r}) \frac{\phi_{0,h}(\mathbf{r})}{\mu_h} + \sum_{h=1}^G \mu_h \Sigma_{s0,g \leftarrow h}(\mathbf{r}) \frac{\phi_{0,h}(\mathbf{r})}{\mu_h} \quad (3.37)$$

$$\frac{2\ell}{4\ell+1} \nabla \cdot \phi_{2\ell-1,g}(\mathbf{r}) + \mu_g \Sigma_{0,g}(\mathbf{r}) \frac{\phi_{2\ell,g}(\mathbf{r})}{\mu_g} + \frac{2\ell+1}{4\ell+1} \nabla \cdot \phi_{2\ell+1,g}(\mathbf{r}) = \sum_{h=1}^G \mu_h \Sigma_{s2\ell,g \leftarrow h}(\mathbf{r}) \frac{\phi_{2\ell,h}(\mathbf{r})}{\mu_h} \quad (3.38)$$

and on odd-parity equations as follows:

$$\frac{2\ell+1}{4\ell+3} \nabla \cdot \phi_{2\ell,g}(\mathbf{r}) + \frac{\Sigma_{1,g}(\mathbf{r})}{\mu_g} \phi_{2\ell+1,g}(\mathbf{r}) + \frac{2\ell+2}{4\ell+3} \nabla \cdot \phi_{2\ell+2,g}(\mathbf{r}) = \sum_{h=1}^G \frac{\Sigma_{s2\ell+1,g \leftarrow h}(\mathbf{r})}{\mu_g} \phi_{2\ell+1,h}(\mathbf{r}) \quad (3.39)$$

where  $\ell \geq 1$ .

In conclusion:

- All  $P_0$  cross sections (including the total cross section NTOTO in the even-parity equations) must be multiplied by  $\mu_g$ .
- The total cross section NTOT1 in the odd-parity equations must be divided by  $\mu_g$ .
- Scattering matrix terms  $\Sigma_{s\ell,g \leftarrow h}(\mathbf{r})$  with  $\ell$  even must be multiplied by  $\mu_h$ .
- Scattering matrix terms  $\Sigma_{s\ell,g \leftarrow h}(\mathbf{r})$  with  $\ell$  odd must be divided by  $\mu_g$ .
- Even parity fluxes (such as NWT0 and FLUX-INTG) must be divided by  $\mu_g$ .
- Odd parity fluxes (such as NWT1 and FLUX-INTG-P1) are not modified.



- In the case where the macro-calculation is done in transport theory, but not with a  $P_n$ -type method, the macroscopic total cross section is *not modified*, and the even-odd corrections consistent with the simplified  $P_n$  method are reported to the macroscopic within-group scattering cross sections. They are now corrected as<sup>[106]</sup>

$$\tilde{\Sigma}_{s2\ell, g \leftarrow g}(\mathbf{r}) = \mu_g \Sigma_{s2\ell, g \leftarrow g}(\mathbf{r}) + (1 - \mu_g) \Sigma_{0, g}(\mathbf{r}) \quad (3.40)$$

and

$$\tilde{\Sigma}_{s2\ell+1, g \leftarrow g}(\mathbf{r}) = \frac{\Sigma_{s2\ell+1, g \leftarrow g}(\mathbf{r})}{\mu_g} + \left(1 - \frac{1}{\mu_g}\right) \Sigma_{1, g}(\mathbf{r}) \quad (3.41)$$

where  $\ell \geq 0$ .

Other cross sections and scattering matrix terms are corrected the same way as for the simplified  $P_n$  method.

### 3.9.1 Data input for module SPH:

The SPH: module perform a SPH equivalence calculation using information recovered in a macrolib and apply SPH factors to the corresponding EDITION (L\_EDIT), MICROLIB (L\_LIBRARY), MACROLIB (L\_MACROLIB) or SAPHYB (L\_SAPHYB) object. This module is also useful to extract a corrected or non-corrected MICROLIB or MACROLIB from the first RHS object. The calling specification is:

Table 48: Structure (SPH:)

```
{ EDINEW | LIBNEW | MACNEW | SAPNEW | CPONEW | EDINAM | LIBNAM | MACNAM
  | SAPNAM | CPONAM | APXNAM }
:= SPH: { EDINAM | LIBNAM | MACNAM | SAPNAM | CPONAM | APXNAM }
{ [ TRKNAM [ TRKFIL ] ] | OPTIM } [ FLUNAM ]
:: (descsph)
```

where

|               |  |
|---------------|--|
| <i>EDINEW</i> | <b>character*12</b> name of the new EDITION data structure containing SPH-corrected information (see Section 3.7). In this case, an existing EDITION data structure must appear on the RHS.                          |
| <i>LIBNEW</i> | <b>character*12</b> name of the new MICROLIB data structure containing SPH-corrected information (see Section 3.2). In this case, an existing EDITION, MICROLIB or MULTICOMPO data structure must appear on the RHS. |
| <i>MACNEW</i> | <b>character*12</b> name of the new MACROLIB data structure containing SPH-corrected information (see Section 3.1).  |
| <i>SAPNEW</i> | <b>character*12</b> name of the new SAPHYB data structure containing SPH information (see Section 3.18). In this case, data structure <i>SAPNAM</i> must appear on the RHS.  |
| <i>CPONEW</i> | <b>character*12</b> name of the new MULTICOMPO data structure containing SPH-corrected information (see Section 3.13). In this case, data structure <i>CPONAM</i> must appear on the RHS.                            |
| <i>EDINAM</i> | <b>character*12</b> name of the existing EDITION data structure where the edition information is recovered (see Section 3.7).  |

|                  |  |
|------------------|--|
| <i>LIBNAM</i>    | <b>character*12</b> name of the existing MICROLIB data structure where the edition information is recovered (see Section 3.2).   |
| <i>MACNAM</i>    | <b>character*12</b> name of the existing MACROLIB data structure where the edition information is recovered (see Section 3.1).   |
| <i>SAPNAM</i>    | <b>character*12</b> name of the existing SAPHYB data structure where the edition information is recovered (see Section 3.18).  |
| <i>CPONAM</i>    | <b>character*12</b> name of the existing MULTICOMPO data structure where the edition information is recovered (see Section 3.13).  |
| <i>APXNAM</i>    | <b>character*12</b> name of the existing APEX or MPO file where the edition information is recovered.  |
| <i>TRKNAM</i>    | <b>character*12</b> name of the existing TRACKING data structure containing the tracking of the macro-geometry (see Section 3.4). This object is compulsory only if a macro-calculation is to be performed by module SPH:.                 |
| <i>TRKFIL</i>    | <b>character*12</b> name of the existing sequential binary tracking file used to store the tracks lengths of the macro-geometry. This file is given if and only if it was required in the previous tracking module call (see Section 3.4). |
| <i>OPTIM</i>     | <b>character*12</b> name of a L_OPTIMIZE object. The SPH factors are set equal to the control-variable data recovered from <i>OPTIM</i> if keyword SPOP is set.  |
| <i>FLUNAM</i>    | <b>character*12</b> name of an initialization flux used to start SPH iterations (see Section 3.6). By default, a flat estimate of the flux is used.  |
| <b>(descsph)</b> | structure containing the input data to this module (see Section 3.9.2).  |

Note: Saphyb files generated by APOLLO2 don't have a signature. If such a Saphyb is given as input to module SPH:, a signature must be included before using it. The following instruction can do the job:

```
Saphyb := UTL: Saphyb :: CREA SIGNATURE 3 = 'L_SA' 'PHYB' ' ' ;
```

### 3.9.2 Specification for the type of equivalence calculation

This structure is used to specify the type of equivalence calculation where the flux and the condensed and/or homogenized cross sections are corrected by SPH factors, in such a way as to respect a specified transport-transport or transport-diffusion equivalence criteria.<sup>[76-78]</sup> This structure is defined as:

Table 49: Structure (**descsph**)

```
[ EDIT iprint ]
[[ STEP { UP NOMDIR | AT index } ]]
[ { IDEM | MACRO | MICRO } ]
[ { OFF | SPRD [ nmerge ngcond (sph(i), i=1, nmerge×ngcond) ] | SPOP | HOMO | ALBS } ]
[ { PN | SN [ BELL ] } ]
[ { STD | SELE_ALB | SELE_FD | SELE_MWG | SELE_EDF | ASYM mixs | STD_FISS } ] [ ARM ]
[ ITER [ maxout ] [ epsout ] ]
[ MAXNB maxnb ]
[ GRMIN lgrmin ] [ GRMAX lgrmax ]
[ { EQUI TEXT4 [ LOCNAM TEXT80 ] | EQUI TEXT80 } ]
[ UPS ] [ LEAK [ b2 ] ]
```

where

|               |  |
|---------------|--|
| EDIT          | keyword used to modify the print level <i>iprint</i> .   |
| <i>iprint</i> | index used to control the printing of this module. The <i>iprint</i> parameter is important for adjusting the amount of data that is printed by this calculation step.   |
| STEP          | keyword used to set a specific elementary calculation from the first RHS.  |
| UP            | keyword used to select an elementary calculation located in a subdirectory of <i>EDINAM</i> or <i>CPONAM</i> . By default, <ul style="list-style-type: none"> <li>• the sub-directory name stored in record 'LAST-EDIT' is selected if <i>EDINAM</i> is defined at RHS.</li> <li>• the sub-directory 'default' is selected if <i>CPONAM</i> is defined at RHS.</li> </ul>  |
| NOMDIR        | name of an existing sub-directory of <i>EDINAM</i> or <i>CPONAM</i> . Can also be used to step up in the <code>output.n</code> group of a MPO file.  |
| AT            | keyword used to select the <i>index</i> -th elementary calculation in <i>SAPNAM</i> , <i>CPONAM</i> or <i>APXNAM</i> .   |
| <i>index</i>  | index of the elementary calculation. Can also be used to step at the <code>statept_(index -1)</code> group of a MPO file.  |
| IDEM          | keyword to force the production of a LHS object of the same type as the RHS (default option).  |
| MACRO         | keyword to force the production of a macrolib at LHS.  |
| MICRO         | keyword to force the production of a microlib at LHS.  |
| OFF           | keyword to specify the SPH factors are all set to 1.0, meaning no correction. This keyword is useful to get rid of a SPH correction which have been set previously. By default, the PN or SN option is activated.  |
| SPRD          | keyword to specify that the SPH factors are read from input (if <i>nmerge</i> , <i>ngcond</i> and <i>sph</i> are set) or recovered from a RHS object (otherwise).  |
| SPOP          | keyword to specify that the SPH factors are recovered from a RHS object of type OPTIMIZE (L_OPTIMIZE).   |
| <i>nmerge</i> | number of regions.   |
| <i>ngcond</i> | number of energy groups.   |
| <i>sph(i)</i> | initial value of each SPH factor in each mixture (inner loop) and each group (outer loop).   |
| HOMO          | keyword to specify that the SPH factors are uniform over the complete macro-geometry. This option is generally used with a complete homogenization of the reference geometry, obtained using option MERG COMP. In this case the neutron flux (transport or diffusion) will be uniform, which allows the SPH factors to be obtained (one per macro-group) using a non-iterative strategy. For a given macro-group the SPH factor will be equal to the ratio between the average flux of the region and the surface flux if the SELE option is used otherwise the SPH factor are all set equal to 1.0 (no correction). The SELE option allows an SPH factor equal to the inverse of the discontinuity factor to be calculated. |

|      |   |
|------|---|
| ALBS | keyword to specify that the albedo of the geometry are to be taken into account in the complete homogenization process. Thus the <b>MERG</b> and <b>COMP</b> options must be specified. The SPH factors are obtained using a transport-transport equivalence based on a calculation using the collision probabilities. This option requires a geometry with <b>VOID</b> (see Section 3.3.2) external boundary conditions to be closed using <b>ALBS</b> in modules <b>ASM</b> : (see Section 3.5.1). <sup>[77]</sup>      |
| PN   | keyword to activate a calculation of heterogeneous SPH factors based on a converging series of macro-calculations with the correction strategy of Eqs. (3.35) to (3.39). This is the default option if the macro-calculation is of diffusion, PN or SPN type. A normalization condition must be set if the macro-geometry has no boundary leakage ( <i>fundamental mode</i> condition). If boundary leakage is present, no normalization condition is used but the SPH iterations are difficult to converge in this case. |
| SN   | keyword to activate a calculation of heterogeneous SPH factors based on a converging series of macro-calculations with the correction strategy of Eqs. (3.40) and (3.41). This is the default option if the macro-calculation is of PIJ, IC, SN or MOC type. A normalization condition must be set if the macro-geometry has no boundary leakage ( <i>fundamental mode</i> condition). If boundary leakage is present, no normalization condition is used but the SPH iterations are difficult to converge in this case.  |
| BELL | keyword to activate the Bell procedure to accelerate the convergence of the SPH factors. This feature is currently available with macro-calculations of PIJ type. <sup>[79]</sup>   |
| STD  | keyword to specify the use of flux-volume normalization for the SPH factors (default option). In each macro-group, the macro-fluxes in macro regions $i$ are normalized using   |

$$\tilde{\phi}_i = \phi_i \frac{\bar{\phi}_{\text{ref}}}{\bar{\phi}_{\text{mc}}}$$

where  $\bar{\phi}_{\text{ref}}$  is the averaged volumic flux of the reference calculation and  $\bar{\phi}_{\text{mc}}$  is the averaged volumic flux of the macro-calculation. Using this definition, the averaged SPH factor is equal to one.

|          |  |
|----------|--|
| SELE_ALB | keyword to specify the use of Selengut normalization for the SPH factors. It is necessary to know the averaged surfacic flux of the reference calculation. Two possibilities exist: <ul style="list-style-type: none"> <li>• We use collision probabilities. We define the reference geometry with <b>VOID</b> external boundary conditions (see Section 3.3.2) and to close the region for the collision probability calculations using the <b>ALBS</b> option (see Section 3.5.1).</li> <li>• We perform a flux calculation with the current iteration method in Eurydice. This option is only available if a <b>SYBILT</b>: tracking is used and if keyword <b>ARM</b> is set in module <b>ASM</b>: (see Section 3.5.1).</li> </ul> |
|----------|--|

|         |  |
|---------|--|
| SELE_FD | keyword to specify the use of Selengut normalization for the SPH factors. It is necessary to know the averaged surfacic flux of the reference calculation. This value can be obtained by defining a small region near boundary in the reference geometry and by using the ADF <b>FD_B</b> data structure in Section 3.7.1. |
|---------|--|

In each macro-group, the macro-fluxes in macro regions  $i$  are normalized using

$$\tilde{\phi}_i = \phi_i \frac{\phi_{\text{ref}}^{\text{gap}}}{\phi_{\text{mc}}}$$

where  $\phi_{\text{ref}}^{\text{gap}}$  is the averaged surfacic flux of the reference calculation. Using this definition, the averaged SPH factor is equal to

$$\bar{\mu} = \frac{\bar{\phi}_{\text{ref}}}{\phi_{\text{ref}}^{\text{gap}}} .$$

SELE\_MWG

keyword to specify the use of Selengut *macro calculation water gap* normalization for the SPH factors.<sup>[80]</sup> It is necessary to know the averaged surfacic flux of the reference and that of the *macro* calculations. This reference value can be obtained by defining a small region near boundary in the reference geometry and by using the ADF\_FD\_B data structure in Section 3.7.1.

In each macro-group, the macro-fluxes in macro regions  $i$  are normalized using

$$\tilde{\phi}_i = \phi_i \frac{\phi_{\text{ref}}^{\text{gap}}}{\phi_{\text{mc}}^{\text{surf}}}$$

where  $\phi_{\text{ref}}^{\text{gap}}$  is the averaged surfacic flux of the reference calculation and  $\phi_{\text{mc}}^{\text{surf}}$  is the averaged surfacic flux of the macro calculation. Using this definition, the averaged SPH factor is equal to

$$\bar{\mu} = \frac{\bar{\phi}_{\text{ref}} \phi_{\text{mc}}^{\text{surf}}}{\bar{\phi}_{\text{mc}} \phi_{\text{ref}}^{\text{gap}}} .$$

SELE\_EDF

keyword to specify the use of generalized Selengut normalization for the SPH factors.<sup>[81]</sup> It is necessary to know the averaged surfacic flux and the averaged volumic flux in a row of cells of the reference calculation. The surfacic flux is obtained as with the SELE option. The value of the volumic flux in a row of cells is computed using index information from the ADF\_FD\_H data structure in Section 3.7.1.

In each macro-group, the macro-fluxes in macro regions  $i$  are normalized using

$$\tilde{\phi}_i = \phi_i \frac{\bar{\phi}_{\text{ref}} \phi_{\text{ref}}^{\text{gap}}}{\bar{\phi}_{\text{mc}} \phi_{\text{ref}}^{\text{row}}}$$

where  $\phi_{\text{ref}}^{\text{gap}}$  is the averaged surfacic flux of the reference calculation and  $\phi_{\text{ref}}^{\text{row}}$  is the averaged volumic flux in a row of cells of the reference calculation. Using this definition, the averaged SPH factor is equal to

$$\bar{\mu} = \frac{\bar{\phi}_{\text{ref}}^{\text{row}}}{\bar{\phi}_{\text{ref}}^{\text{gap}}} .$$

ASYM

keyword to specify the use of asymptotic normalization of the SPH factors. The SPH factors in homogenized mixture *mixs* are set to one in all macro-energy groups.

*mixs*

index of the homogenized mixture where asymptotic normalization is performed.

STD\_FISS

keyword to specify the use of flux-volume normalization in all *fissile zones* for the SPH factors. This option is useful for representing assemblies containing reflector zones.

ARM

keyword to activate a solution technique other than the collision probability method. Used with the Eurydice solution technique within SYBILT: to activate the current iteration method.

ITER

keyword to specify the main convergence parameters used to control SPH iterations.

*maxout*

user-defined maximum number of SPH iterations (default value: 200).

*epsout*

user-defined convergence criterion (default value:  $1.0 \times 10^{-4}$ ).

MAXNB

keyword to specify an auxiliary convergence parameter used to control SPH iterations.

*maxnb*

acceptable number of SPH iterations with an increase in convergence error before aborting (default value: 10).

GRMIN

keyword to specify the minimum group index considered during the equivalence process.

|               |   |
|---------------|---|
| <i>lgrmin</i> | first group number considered during the equivalence process. By default, <i>lgrmin</i> = 1.  |
| GRMAX         | keyword to specify the maximum group index considered during the equivalence process.   |
| <i>lgrmax</i> | last group index considered during the equivalence process. By default, <i>lgrmax</i> is set to the last group index in the RHS macrolib.   |
| EQUI          | keyword used to select an existing set of SPH factors in <i>SAPNAM</i> or to store a new set of SPH factors in <i>SAPNEW</i> or <i>SAPNAM</i> . Also used as <i>EQUI TEXT80</i> to select an existing set of SPH factors in <i>APXNAM</i> or to store a new set of SPH factors in <i>APXNAM</i> . |
| <i>TEXT4</i>  | character*4 user-defined keyword of a set of SPH factors. This keyword is related to variable <i>parkey</i> , as defined in Sect. 3.18.1 for a local variable.  |
| LOCNAM        | keyword used to define a character*80 name for the set of SPH factors, if this set is created. By default, <i>TEXT80</i> is taken equal to <i>TEXT4</i> .   |
| <i>TEXT80</i> | character*80 user-defined name associated to keyword <i>TEXT4</i> . This name is related to variable <i>parnam</i> , as defined in Sect. 3.18.1 for a local variable. Also used to identify a set of SPH factors in an APEX or MPO file.  |
| UPS           | keyword to specify that the macrolib and/or microlib cross sections recovered from a Saphyb, APEX or MPO file are corrected so as to eliminate up-scattering. This option is useful for reactor analysis codes which cannot take into account such cross sections.                                |
| LEAK          | keyword used to introduce leakage in the embedded MACROLIB. The buckling is recovered from a RHS MULTICOMPO, SAPHYB, APEX or MPO database. Otherwise, the buckling is recovered from optional variable <i>b2</i> . This option should only be used for non-regression tests.                      |
| <i>b2</i>     | the imposed buckling corresponding to the leakage.  |

### 3.10 The CFC: module

The CFC: module is used to generate a Feedback Model database required for a full core calculation in DONJON.<sup>[100]</sup> The general specifications of this module are:

Table 50: Structure (CFC:)

```
CFCNAM := CFC: [ CFCNAM ]
           (CPONAM(i), i=1,28) :: (descffc)
```

where

*CFCNAM*      **character\*12** name of the FBMSDB data structure containing the Feedback Model reactor database. The reactor database can be updated if *CFCNAM* appears on the RHS.

*CPONAM*      **character\*12** name of read only CPO data structures. There are 28 different CPO data structures required here each containing respectively

1. the reactor reference cross section.
2. cell cross section for the first fuel temperature.
3. cell cross section for the second fuel temperature.
4. cell cross section for the first coolant temperature.
5. cell cross section for the second coolant temperature.
6. cell cross section for the first moderator temperature.
7. cell cross section for the second moderator temperature.
8. cell cross section for the first coolant density.
9. cell cross section for the second coolant density.
10. cell cross section for the first moderator density.
11. cell cross section for the second moderator density.
12. cell cross section for a different concentration of boron.
13. cell cross section for a different moderator purity.
14. cell cross section for a different concentration of xenon.
15. cell cross section for a different concentration of samarium.
16. cell cross section for a different concentration of neptunium.
17. cell cross section for the spectral mixed effect fuel/coolant density.
18. cell cross section for the spectral mixed effect coolant density/temperature.
19. cell cross section for low power history.
20. cell cross section for intermediate power history.
21. cell cross section for high power history.
22. reactor reference moderator cross section.
23. moderator cross section for the first moderator temperature.
24. moderator cross section for the second moderator temperature.
25. moderator cross section for the first moderator density.
26. moderator cross section for the second moderator density.

- 27. moderator cross section for a different concentration of boron.
- 28. moderator cross section for a different moderator purity.

(**descfc**) structure containing the input data to this module (see Section 3.10.1).

### 3.10.1 Data input for module CFC:

Table 51: Structure (**descfc**)

```
[ EDIT iprint ]
[ INFOR TITLE ]
[ DNAME RNAME ]
[ PWR powerref powerup powerint powerdown ]
[ TCOOL tcoolref tcoolup tcooldown ]
[ TMODE tmoderef tmodeup tmodedown ]
[ TFUEL tfuelref tfuelup tfueldown ]
[ RHOC denscool]
[ RHOM densmode]
[ XIR purityref puritydown ]
```

where

|                  |  |
|------------------|--|
| EDIT             | keyword used to modify the print level <i>iprint</i> .                                   |
| <i>iprint</i>    | index used to control the printing of the module.  |
| INFOR            | keyword which allows to set the title.   |
| <i>TITLE</i>     | <b>character*72</b> title associated to the reactor database generated.                  |
| DNAME            | keyword to set a specific database name in the data structure.                           |
| <i>RNAME</i>     | <b>character*12</b> name of the feedback database.                                       |
| PWR              | keyword to specify power used for evolution for power history.                           |
| <i>powerref</i>  | power value for regular power history ( <i>CPONAM</i> default).                          |
| <i>powerup</i>   | power value for high power history ( <i>CPONAM</i> 21).                                  |
| <i>powerint</i>  | power value for intermediate power history ( <i>CPONAM</i> 20).                          |
| <i>powerdown</i> | power value for low power history ( <i>CPONAM</i> 19).                                   |
| TCOOL            | keyword to specify coolant temperature used for regular evolution and perturbed cases.   |
| <i>tcoolref</i>  | normal coolant temperature ( <i>CPONAM</i> default).                                     |
| <i>tcoolup</i>   | high coolant temperature ( <i>CPONAM</i> 4).   |
| <i>tcooldown</i> | low coolant temperature ( <i>CPONAM</i> 5).  |
| TMODE            | keyword to specify moderator temperature used for regular evolution and perturbed cases. |



|                   |   |
|-------------------|---|
| <i>tmoderef</i>   | normal moderator temperature ( <i>CPONAM</i> default).  |
| <i>tmodeup</i>    | high moderator temperature ( <i>CPONAM</i> 6 and 23).   |
| <i>tmodedown</i>  | low moderator temperature ( <i>CPONAM</i> 7 and 24).  |
| <b>TFUEL</b>      | keyword to specify fuel temperature used for regular evolution and perturbed cases.               |
| <i>tfuelref</i>   | normal fuel temperature ( <i>CPONAM</i> default).   |
| <i>tfuelup</i>    | high fuel temperature ( <i>CPONAM</i> 2).   |
| <i>tfueldown</i>  | low fuel temperature ( <i>CPONAM</i> 3).  |
| <b>RHOC</b>       | keyword to specify coolant density used for regular evolution.                                    |
| <i>denscool</i>   | normal coolant density ( <i>CPONAM</i> default).  |
| <b>RHOM</b>       | keyword to specify moderator density used for regular evolution.                                  |
| <i>densmode</i>   | normal moderator density ( <i>CPONAM</i> default).  |
| <b>XIR</b>        | keyword to specify water purity ( $D_2O$ content) used for regular evolution and perturbed cases. |
| <i>purityref</i>  | normal moderator purity (fraction of $D_2O$ in water) ( <i>CPONAM</i> default).                   |
| <i>puritydown</i> | perturbed moderator purity (fraction of $D_2O$ in water) ( <i>CPONAM</i> 13 and 28).              |

Note: Other perturbed values are recovered directly from the concentrations and isotope densities stored in the different *CPONAM*.

### 3.11 The INFO: module

The `INFO:` module is mainly used to compute the number densities for selected isotopes at specific local conditions. The module can also be used to compute the density  $\rho(T, p, x)$  for a mixture containing a fraction  $x$  of heavy and  $(1 - x)$  of light water according at a temperature  $T$  and pressure  $p$ :

$$\rho(T, p, x) = \frac{\rho_{H_2O}(T, p) \rho_{D_2O}(T, p)}{x \rho_{H_2O}(T, p) + (1 - x) \rho_{D_2O}(T, p)} .$$

where  $\rho_{H_2O}(T, p)$  and  $\rho_{D_2O}(T, p)$  will take different forms depending on the option selected.<sup>[101]</sup>

The calling specifications are:

Table 52: Structure (**INFO:**)

```
INFO: :: (descinfo)
```

where

**(descinfo)** structure containing the input data to this module (see Section 3.11.1).

#### 3.11.1 Data input for module `INFO:`

Table 53: Structure (**info**)

```
[ EDIT iprint ]
[ LIB: { DRAGON | MATXS | MATXS2 | WIMSD4 | WIMSAECL | NDAS | APLIB2 | APLIB1 }
  FIL: NAMEFIL ]
[ TMP: temp { K | C } ]
[ PUR: purity { WGT% | ATM% } ]
[ PRES: pressure { bar | Pa | kPa | MPa } ]
[ CALC DENS { WATER >>dens<< | PWATER >>dens<< } ]
[ ENR: enrichment { WGT% | ATM% } ]
[[ ISO: nbiso (ISONAM(i), i=1,nbiso)
  { GET MASS (>>mass(i)<<, i=1,nbiso) | CALC WGT% {
    D20 >>nh1<< >>hd2<< >>no16<< |
    H2O >>nh1<< >>hd2<< >>no16<< |
    UO2 >>nu5<< >>hu8<< >>no16<< |
    THO2 >>nth2<< >>nu3<< >>no16<< } } ]]
```

where

`EDIT` keyword used to modify the print level *iprint*.

*iprint* index used to control the printing of the module. The amount of output produced by this tracking module will vary substantially depending on the print level specified.

|                   |   |
|-------------------|---|
| LIB:              | keyword to specify the type of library from which the isotopic mass ratio is to be read.  |
| DRAGON            | keyword to specify that the isotopic depletion chain or the microscopic cross sections are in the DRAGLIB format.   |
| MATXS             | keyword to specify that the microscopic cross sections are in the MATXS format of NJOY-II and NJOY-89 (no depletion data available for libraries using this format).  |
| MATXS2            | keyword to specify that the microscopic cross sections are in the MATXS format of NJOY-91 (no depletion data available for libraries using this format).  |
| WIMSD4            | keyword to specify that the isotopic depletion chain and the microscopic cross sections are in the WIMSD4 format.   |
| WIMSAECL          | keyword to specify that the isotopic depletion chain and the microscopic cross sections are in the WIMS-AECL format.  |
| NDAS              | keyword to specify that the isotopic depletion chain and the microscopic cross sections are in the NDAS format, as used in recent versions of WIMS-AECL.  |
| APLIB1            | keyword to specify that the microscopic cross sections are in the APOLLO-1 format.  |
| APLIB2            | keyword to specify that the microscopic cross sections are in the APOLLO-2 format.  |
| FIL:              | keyword to specify the name of the file where is stored the mass ratio data.  |
| NAMEFIL           | <b>character*8</b> name of the library where the mass ratio are stored.   |
| TMP:              | keyword to specify the isotopic temperature.  |
| <i>temp</i>       | temperature $T$ in K or C.  |
| PUR:              | keyword to specify the water purity, that is fraction of heavy water in a mix of heavy and light water.   |
| <i>purity</i>     | percent weight ( <b>WGT%</b> ) or atomic ( <b>ATM%</b> ) fraction of heavy water in a mix of heavy and light water ( $100 \times x$ ).  |
| PRES:             | keyword to specify the pressure.  |
| <i>pressure</i>   | pressure $p$ in <b>bar</b> , <b>Pa</b> , <b>kPa</b> or <b>MPa</b> .   |
| ENR:              | keyword to specify the fuel enrichment.   |
| <i>enrichment</i> | fuel enrichment in weight percent ( <b>WGT%</b> ) or atomic percent ( <b>ATM%</b> ).  |
| ISO:              | keyword to specify an isotope list. This list will be used either for getting mass values of isotopes or for computing number densities.  |
| <i>niso</i>       | number of isotopic names used for a calculation (limited to $niso \leq 3$ ).  |
| ISONAM            | <b>character*12</b> name of an isotope.   |
| GET MASS          | keyword to recover the mass values as written in the library. It returns the mass value of each isotope in the output parameter <i>mass</i> .   |
| CALC              | keyword to ask the module to compute some parametric values. It returns one value in the output parameter <i>dens</i> .   |
| DENS              | compute density of a mixture of light and heavy water.  |
| WATER             | keyword to recover the water density as a function of its temperature and purity (independent of pressure $p$ ). This option requires the setting of temperature and purity, and it does not affect any given list of isotope names. This module relies on the water density calculator of WIMS-AECL. <sup>[38]</sup> |

|           |  |
|-----------|--|
| PWATER    | <p>new keyword to recover the water density as a function of temperature, pressure and purity developed by C. Kieffer.<sup>[101]</sup> This option requires the setting of temperature, pressure and purity, and it does not affect any given list of isotope names. For light water, it uses the <code>freesteam</code> routines.<sup>[102]</sup> For heavy water, two options are considered.</p> <ol style="list-style-type: none"> <li>1. For <math>90\text{ C} &lt; T &lt; 350\text{ C}</math> and <math>p &lt; 22\text{ MPa}</math>, the heavy water routines written by Ji Zhang at AECL and distributed freely by B. Garland from McMaster University are considered.<sup>[103]</sup></li> <li>2. Otherwise, the density is that of obtained from <code>freesteam</code> multiplied by a factor of 1.11 which is approximately the ratio of the molecular mass of D2O to H2O.</li> </ol> |
| WGT% D2O  | <p>keywords to recover 3 number densities for a compound mixture of heavy and light water. The isotope list is assumed to contain <math>^1\text{H}</math>, <math>^2\text{D}</math> and <math>^{16}\text{O}</math>. Temperature and purity are supposed to be available. It returns concentration of these isotopes in the output parameters <code>nh1</code>, <code>nd2</code> and <code>no16</code>.</p>  |
| WGT% H2O  | <p>is identical to WGT% D2O.</p>   |
| WGT% UO2  | <p>keywords to recover 3 number densities for a compound mixture of Uranium oxide. The isotope list is assumed to contain <math>^{235}\text{U}</math>, <math>^{238}\text{U}</math> and <math>^{16}\text{O}</math>. The <math>^{235}\text{U}</math> enrichment is supposed to be available. Note that the number densities will sum to 100. It returns concentration of these isotopes in the output parameters <code>nu5</code>, <code>nu8</code> and <code>no16</code>.</p>   |
| WGT% THO2 | <p>keywords to recover 3 number densities for a compound mixture of Thorium/Uranium oxide. The isotope list is assumed to contain <math>^{232}\text{Th}</math>, <math>^{233}\text{U}</math> and <math>^{16}\text{O}</math>. The <math>^{233}\text{U}</math> enrichment is supposed to be available. Note that the number densities will sum to 100. It returns concentration of these isotopes in the output parameters <code>nth2</code>, <code>nu3</code> and <code>no16</code>.</p>   |

The `INFO:` module works the following way. For a given isotope list, the mass is extracted from the library or a calculation process is expected. Once this calculation is has been performed, it is possible to list other isotopes and ask for further calculations. Finally note that the number of output parameters, denoted by `>>param<<`, are recovered as CLE-2000 variables in (`descinfo`). The number of these parameters must be equal to the number of isotopes names given, plus the water density when a command `CALC DENS WATER` is issued.

### 3.12 The MRG: module

The MRG: module is used to pre-homogenize a geometry after it has been tracked with the EXCELT: module. This module can also be used for the same purpose for NXT: tracked geometries.<sup>[83,84,115]</sup> In addition, NXT: based tracking files can also be partition using this module.

The general specifications for this module are presented in Table 54 to 56

Table 54: Structure for merging EXCELT: tracks

|   |
|---|
| <i>TRKNEW TFILENEW</i> := MRG: <i>TRKEOLD TFILEOLD</i> :: (descmrg) |
|---|

Table 55: Structure for merging NXT: tracks

|  |
|--|
| <i>TRKNNEW</i> := MRG: <i>TRKNOLD</i> :: (descmrg) |
|--|

Table 56: Structure for partitioning NXT: tracking files

|  |
|--|
| <i>TFILEMOD TFILEEXT</i> := MRG: <i>TRKNOLD TFILEOLD</i> :: (descextr) |
|--|

|                 |   |
|-----------------|---|
| <i>TRKNEW</i>   | <b>character*12</b> name of the new TRACKING data structure that will contain region volume and surface area vectors in addition to region identification pointers and other tracking information after the pre-homogenization process. |
| <i>TFILENEW</i> | <b>character*12</b> name of the new EXCELT: compatible sequential binary tracking file used to store the tracks lengths after the pre-homogenization process has take place.  |
| <i>TFILEMOD</i> | <b>character*12</b> name of the new NXT: sequential binary tracking file where the lines not-associated with the regions to extract are stored.   |
| <i>TFILEEXT</i> | <b>character*12</b> name of the new NXT: compatible sequential binary tracking file where the lines associated with the regions to extract are stored.  |
| <i>TRKEOLD</i>  | <b>character*12</b> name of the TRACKING data structure that contains region volume and surface area vectors in addition to region identification pointers and other tracking information before the pre-homogenization process.        |
| <i>TFILEOLD</i> | <b>character*12</b> name of the old sequential binary tracking file used to store the tracks lengths before the pre-homogenization process takes place.   |
| (descmrg)       | structure containing the input data to this module (see Section 3.12.1).  |
| (descextr)      | structure containing the input data for track file partitioning process (see Section 3.12.2).   |

## 3.12.1 Data input for geometry pre-homogenization

Table 57: Structure (**descmrg**)

|  |
|--|
| [ EDIT <i>iprint</i> ]   |
| [ REGI ( <i>irmrg</i> ( <i>i</i> ), <i>i</i> =1, <i>nreg</i> ) ] |
| [ SURF ( <i>ismrg</i> ( <i>i</i> ), <i>i</i> =1, <i>nsur</i> ) ] |

|               |  |
|---------------|--|
| EDIT          | keyword used to modify the print level <i>iprint</i> .   |
| <i>iprint</i> | index used to control the printing in this module.   |
| REGI          | keyword to specify that regions will be pre-homogenized.   |
| <i>irmrg</i>  | list of new region numbers associated with old region numbers. Two or more regions can be combined together only if they contain the same mixture. The number <i>nreg</i> of region is that printed after the execution of the tracking module.                              |
| SURF          | keyword to specify that surfaces will be pre-homogenized.  |
| <i>ismrg</i>  | list of new surface numbers associated with old surface numbers. Two or more surfaces can be combined together only if they are associated with the same boundary conditions. The number <i>nsur</i> of surfaces is that printed after the execution of the tracking module. |

## 3.12.2 Data input for tracking file partitioning

Table 58: Structure (**descextr**)

|   |
|---|
| [ EDIT <i>iprint</i> ]  |
| [ EXTR ( <i>iext</i> ( <i>i</i> ), <i>i</i> =1, <i>nreg</i> ) ] |

where

|               |   |
|---------------|---|
| EDIT          | keyword used to modify the print level <i>iprint</i> .  |
| <i>iprint</i> | index used to control the printing in this module.  |
| EXTR          | keyword to specify that the track associated with a specific set of regions will be extracted from the reference tracking file.           |
| <i>iext</i>   | list of region numbers for track extraction. The number <i>nreg</i> of region is that printed after the execution of the tracking module. |

### 3.13 The COMPO: module

This component of the lattice code is dedicated to the constitution of the reactor database intended to store *all* the nuclear data, produced in the lattice code, that is useful in reactor calculations including fuel management and space-time kinetics. Multigroup lattice calculations are too expensive to be executed dynamically from the driver of the global reactor calculation. A more feasible approach is to create a reactor database where a finite number of lattice calculation results are tabulated against selected *global* and/or *local parameters* chosen so as to represent expected operating conditions of the reactor.

The COMPO: module is used to create and construct a MULTICOMPO object. This object is generally *persistent* and used to collect information gathered from many DRAGON *elementary calculations* performed under various conditions.

For each elementary calculation, the results are recovered from the output of the EDI: module and stored in a list of *homogenized mixture* directories. The EDI: module is responsible for performing condensation in energy, homogenization in space of the microscopic cross sections and constitution of *macroscopic sets* for collecting together many isotopes. All the elementary calculations gathered in a single MULTICOMPO object are characterized by the same number of *homogenized mixtures* and by a specific output energy-group structure.

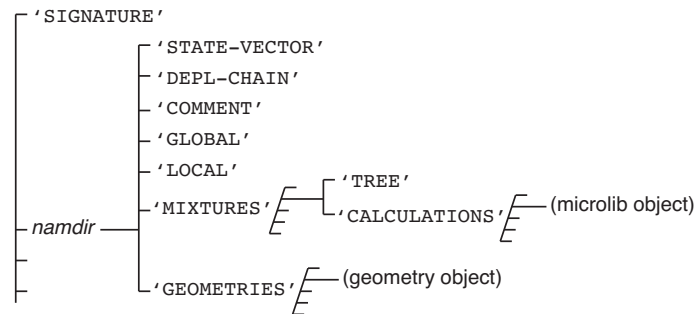

Figure 20: Organization of a multicompo object.

Each elementary calculation is characterized by a tuple of *global* and/or *local parameters*. Global parameters are characteristics of the complete lattice, while local parameters are characteristics of each homogenized mixture. These parameters are of different types, depending on the nature of the study under consideration: type of assembly, power, temperature in a mixture, concentration of an isotope, time, burnup or exposure rate in a depletion calculation, etc. Each step of a depletion calculation represents an elementary calculation. The MULTICOMPO object is often presented as a *multi-parameter reactor database*.

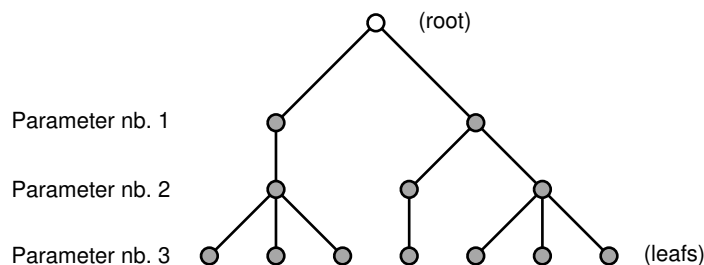

Figure 21: Parameter tree in a MULTICOMPO object

The MULTICOMPO object is organized as shown in Figure 20. The root of the object contains table-of-content information for global and local parameters and two lists of directories. Each component of the first list ('MIXTURES') contains the directory 'TREE' (the parameter tree) and the list ('CALCULATIONS') made of MICROLIB objects. Each component of the second list ('GEOMETRIES') contains the homogenized

geometry of an elementary calculation.

The localization of an elementary calculation is done using a tuple of global and/or local parameters. The elementary calculation indices are stored in a tree with the number of levels equal to the number of global and local parameters. An example of a tree with three parameters is shown in Figure 21. Each node of this tree is associated with the index of the corresponding parameter and with the reference to the daughter nodes if they exist. The number of leaves is equal to the number of nodes for the last (third) parameter and is equal to the number of elementary calculations stored in the MULTICOMPO object. The index of each elementary calculation is therefore an attribute of each leaf.

In each homogenized mixture component, the `COMPO:` module recovers cross sections for a number of *particularized isotopes* and of a single *macroscopic set*, a collection of the remaining isotopic cross sections weighted by isotopic number densities. Other information is also recovered: multigroup neutron fluxes, isotopic number densities, fission spectrum, delayed neutron data, etc.

A different specification of the `COMPO:` function call is used for creation and construction of the MULTICOMPO object.

- The first specification is used to initialize the MULTICOMPO data structure and to set the choice of global and local parameters.
- A modification call to the `COMPO:` function is performed after each elementary calculation in order to recover output information processed by `EDI:` (condensed and homogenized cross sections) and `EVO:` (burnup dependant values). Global and local parameters can optionally be recovered from MICROLIB objects.
- Another modification call to the `COMPO:` function is used to concatenate a *read-only* MULTICOMPO object into a *master* MULTICOMPO object.

The calling specifications are:

Table 59: Structure (`COMPO:`)

```
{ CPONAM := COMPO: [ CPONAM ] :: (compo_data1)
| CPONAM := COMPO: CPONAM EDINAM [ EDINA2 ] [ BRNNAM ] [ HMIC1 [ HMIC2 ] ]
  :: (compo_data2)
| CPONAM := COMPO: CPONAM CPORHS :: (compo_data3)
| COMPO: CPONAM :: (compo_data4) }
```

where

|                     |   |
|---------------------|---|
| <code>CPONAM</code> | <code>character*12</code> name of the LCM object containing the <i>master</i> MULTICOMPO data structure.  |
| <code>EDINAM</code> | <code>character*12</code> name of the LCM object (type <code>L_EDIT</code> ) containing the EDITION data structure corresponding to an elementary calculation. This EDITION data structure is containing homogenized and condensed cross-section information. The EDITION data produced by the last call to the <code>EDI:</code> module is used. It is possible to provide a MACROLIB data structure as replacement for the EDITION data structure. In this case, the <code>MACRO</code> keyword is automatically set. |
| <code>EDINA2</code> | <code>character*12</code> name of an optional LCM object (type <code>L_EDIT</code> ) containing the EDITION data structure corresponding to an elementary calculation. This EDITION data structure is containing <i>group form factor</i> information. The EDITION data produced by the last call to the <code>EDI:</code> module is used.  |
| <code>BRNNAM</code> | <code>character*12</code> name of the LCM object (type <code>L_BURNUP</code> ) containing the BURNUP data structure.  |



|                    |   |
|--------------------|---|
| <i>HMIC1</i>       | <code>character*12</code> name of a MICROLIB (type <code>L_LIBRARY</code> ) containing global parameter information.  |
| <i>HMIC2</i>       | <code>character*12</code> name of a MICROLIB (type <code>L_LIBRARY</code> ) containing global parameter information.  |
| <i>CPORHS</i>      | <code>character*12</code> name of the <i>read-only</i> MULTICOMPO data structure. This data structure is concatenated to <i>CPONAM</i> using the <i>compo_data3</i> data structure, as presented in Section 3.13.3. <i>CPORHS</i> must be defined with the same number of energy groups and the same number of homogeneous regions as <i>CPONAM</i> . Moreover, all the global and local parameters of <i>CPORHS</i> must be defined in <i>CPONAM</i> . <i>CPONAM</i> may be defined with <i>global</i> parameters not defined in <i>CPORHS</i> . |
| <i>compo_data1</i> | input data structure containing initialization information (see Section 3.13.1).  |
| <i>compo_data2</i> | input data structure containing information related to the recovery of an elementary calculation (see Section 3.13.2).  |
| <i>compo_data3</i> | input data structure containing information related to the catenation of a <i>read-only</i> MULTICOMPO (see Section 3.13.3).  |
| <i>compo_data4</i> | input data structure containing information related to the display of a <i>read-only</i> MULTICOMPO (see Section 3.13.4).   |

### 3.13.1 Initialization data input for module COMPO:

Table 60: Structure (**compo\_data1**)

```
[ EDIT iprint ]
[[ [ STEP UP NAMDIR ]
  [ MAXCAL maxcal ]
  [ COMM [[ HCOM ]] ENDC ]
  [[ PARA PARKEY
    { TEMP HMIC imix | CONC HISO1 HMIC imix | IRRA | FLUB |
      POWR | MASL | FLUX | TIME | VALU { REAL | CHAR | INTE } }
  ]]
  [[ LOCA PARKEY
    { TEMP | CONC HISO2 | IRRA | FLUB | FLUG | POWR | MASL | FLUX }
  ]]
  [ ISOT nisp (HISOP(i),i=1,nisp) ]
  [ GFF ] [ { NOALBP | ALBP } ] [ { NOJSURF | JSURF } ]
  INIT ]]
;
```

where

|                   |  |
|-------------------|--|
| <code>EDIT</code> | keyword used to set <i>iprint</i> .  |
| <i>iprint</i>     | index used to control the printing in module <code>COMPO</code> :. =0 for no print; =1 for minimum printing (default value).   |
| <code>STEP</code> | keyword used to create the database from a sub-directory named <i>NAMDIR</i> . This capability make possible the creation of a single object with many independent MULTICOMPO structures in it. By default, the database is created on directory ' <code>default</code> '. |

|               |   |
|---------------|---|
| UP            | keyword used to move up towards a sub-directory of <i>CPONAM</i> .  |
| NAMDIR        | create the MULTICOMPO structure in the sub-directory named <i>NAMDIR</i> .  |
| MAXCAL        | keyword used to set <i>maxcal</i> .   |
| <i>maxcal</i> | maximum number of elementary calculations to be stored in the MULTICOMPO. <i>maxcal</i> = 10 by default. This maximum size is automatically increased when the number of elementary calculations exceeds the current value of <i>maxcal</i> . |
| COMM          | keyword used to input a general comment for the MULTICOMPO.   |
| HCOM          | <b>character*80</b> user-defined comment.   |
| ENDC          | end-of-HCOM keyword.  |
| PARA          | keyword used to define a single global parameter.   |
| LOCA          | keyword used to define a single local parameter.  |
| PARKEY        | <b>character*12</b> user-defined keyword associated to a global or local parameter.   |
| HMIC          | <b>character*12</b> name of the MICROLIB (type <b>L-LIBRARY</b> ) associated to a global parameter. The corresponding MICROLIB will be required on RHS of the <b>COMPO</b> : call described in Sect. 3.13.2.                                  |
| <i>imix</i>   | index of the mixture associated to a global parameter. This mixture is located in MICROLIB named <i>HMIC</i> .  |
| HISO1         | <b>character*8</b> alias name of the isotope associated to a global parameter. This isotope is located in MICROLIB data structure named <i>HMIC</i> .   |
| HISO2         | <b>character*8</b> alias name of the isotope associated to a local parameter. This isotope is located in the MICROLIB directory of the EDITION data structure named <i>EDINAM</i> .   |
| TEMP          | keyword used to define a temperature (in Kelvin) as global or local parameter.  |
| CONC          | keyword used to define a number density as global or local parameter.   |
| IRRA          | keyword used to define a burnup (in MWday/Tonne) as global or local parameter.  |
| FLUB          | keyword used to define a <i>fuel-only</i> exposure rate (in n/kb) as global or local parameter. The exposure rate is recovered from the <i>BRNNAM</i> LCM object.   |
| FLUG          | keyword used to define an exposure rate in global homogenized mixtures (in n/kb) as local parameter. The exposure rate is recovered from the <i>BRNNAM</i> LCM object.  |
| POWR          | keyword used to define the power as global or local parameter.  |
| MASL          | keyword used to define the mass density of heavy isotopes as global or local parameter.   |
| FLUX          | keyword used to define the volume-averaged, energy-integrated flux as global or local parameter.  |
| TIME          | keyword used to define the time (in seconds) as global parameter.   |
| VALU          | keyword used to define a user-defined quantity as global parameter. This keyword must be followed by the type of parameter.   |
| REAL          | keyword used to indicate that the user-defined global parameter is a floating point value.  |
| CHAR          | keyword used to indicate that the user-defined global parameter is a <b>character*12</b> value.   |

|              |   |
|--------------|---|
| INTE         | keyword used to indicate that the user-defined global parameter is an integer value.  |
| ISOT         | keyword used to select the set of particularized isotopes. By default, all the isotopes available in the EDITION data structure <i>EDINAM</i> are selected.         |
| <i>nisp</i>  | number of user-defined particularized isotopes.   |
| <i>HISOP</i> | <b>character*8</b> names of the user-defined particularized isotopes. These names must be present in the EDITION data structure <i>EDINAM</i> .                     |
| GFF          | keyword used to enable the recovery of group form factor information from EDITION data structure <i>EDINA2</i> .  |
| NOALBP       | keyword used to avoid the recovery of physical albedo information from EDITION data structure <i>EDINAM</i> .   |
| ALBP         | keyword used to enable the recovery of physical albedo information from EDITION data structure <i>EDINAM</i> (default option).                                      |
| NOJSURF      | keyword used to avoid the recovery of discontinuity factor and boundary multigroup current information from EDITION data structure <i>EDINAM</i> .                  |
| JSURF        | keyword used to enable the recovery of discontinuity factor and boundary multigroup current information from EDITION data structure <i>EDINAM</i> (default option). |
| INIT         | keyword used to create the empty structure in the MULTICOMPO.   |

## 3.13.2 Modification data input for module COMPO:

Table 61: Structure (**compo\_data2**)

```
[ EDIT iprint ]
[ ALLX ]
[ STEP UP { NAMDIR | * } ]
[ ORIG orig ]
[[ PARKEY value ]]
[ MACRO ] [ SET xtr { S | DAY | YEAR } ]
;
```

where

|               |   |
|---------------|---|
| EDIT          | keyword used to set <i>iprint</i> .   |
| <i>iprint</i> | index used to control the printing in module COMPO: . =0 for no print; =1 for minimum printing (default value).   |
| ALLX          | keyword used to register the region number of each isotope before merging. This option is useful if the same keyword has been specified in EDI: before. This allows to perform subsequent depletion calculations, in taking into account different fuel regions in the diffusion calculation. |
| STEP          | keyword used to access the database from a sub-directory named <i>NAMDIR</i> instead of accessing it from the root of <i>CPONAM</i> .   |
| UP            | keyword used to move up towards a sub-directory of <i>CPONAM</i> .  |
| <i>NAMDIR</i> | access the MULTICOMPO structure in the sub-directory named <i>NAMDIR</i> .  |
| *             | use a sub-directory name identical to the directory in <i>EDINAM</i> where the edition data is coming from.   |
| ORIG          | keyword used to define the father node in the parameter tree. By default, the index of the previous elementary calculation is used.   |
| <i>orig</i>   | index of the elementary calculation associated to the father node in the parameter tree.  |
| <i>PARKEY</i> | <b>character*12</b> keyword associated to a user-defined global parameter.  |
| <i>value</i>  | floating-point, integer or <b>character*12</b> value of a user-defined global parameter.  |
| MACRO         | keyword used to recover cross-section information from the macrolib directory in <i>EDINAM</i> . By default, the cross-section information is recovered from the microlib in <i>EDINAM</i> .  |
| SET           | keyword used to recover the flux normalization factor already stored on <i>BRNNAM</i> from a sub-directory corresponding to a specific time.  |
| <i>xtr</i>    | time associated with the current flux calculation. The name of the sub-directory where this information is stored will be given by 'DEPL-DAT'//CNN where CNN is a <b>character*4</b> variable defined by WRITE(CNN, '(I4.4)') INN where INN is an index associated with the time <i>xtr</i> . |
| S             | keyword to specify that the time is given in seconds.   |

|      |   |
|------|---|
| DAY  | keyword to specify that the time is given in days.  |
| YEAR | keyword to specify that the time is given in years. |

### 3.13.3 Modification (catenate) data input for module COMPO:

Table 62: Structure (**compo\_data3**)

```
[ EDIT iprint ]
[ STEP UP NAMDIR ]
[ ORIG orig ]
[[ PARKEY value ]]
[ WARNING-ONLY ]
;
```

where

|               |  |
|---------------|--|
| EDIT          | keyword used to set <i>iprint</i> .  |
| <i>iprint</i> | index used to control the printing in module COMPO: . =0 for no print; =1 for minimum printing (default value).  |
| STEP          | keyword used to access the database from a sub-directory named <i>NAMDIR</i> instead of accessing it from the root of <i>CPONAM</i> .  |
| UP            | keyword used to move up towards a sub-directory of <i>CPONAM</i> .   |
| <i>NAMDIR</i> | access the MULTICOMPO structure in the sub-directory named <i>NAMDIR</i> .   |
| ORIG          | keyword used to define the father node in the parameter tree. By default, the index of the previous elementary calculation is used.  |
| <i>orig</i>   | index of the elementary calculation associated to the father node in the parameter tree.   |
| <i>PARKEY</i> | <b>character*12</b> keyword associated to a global parameter that is specific to <i>CPONAM</i> (not defined in <i>CPORHS</i> ).  |
| <i>value</i>  | floating-point, integer or <b>character*12</b> value of a global parameter that is specific to <i>CPONAM</i> .   |
| WARNING-ONLY  | This option is useful if an elementary calculation in <i>CPORHS</i> is already present in <i>CPONAM</i> . If this keyword is set, a warning is send and the <i>CPONAM</i> values are kept, otherwise the run is aborted (default). |

## 3.13.4 Display data input for module COMPO:

Table 63: Structure (**compo\_data4**)

```
[ EDIT iprint ]
[ STEP UP NAMDIR ]
DB-STRUC
;
```

where

**EDIT** keyword used to set *iprint*.

*iprint* index used to control the printing in module COMPO: . <2 for MUPLET display only (default value) and parameters values are presented at the end, ≥2 for the parameter value display for each calculation.

**STEP** keyword used to access the database from a sub-directory named *NAMDIR* instead of accessing it from the root of *CPONAM*.

**UP** keyword used to move up towards a sub-directory of *CPONAM*.

*NAMDIR* access the MULTICOMPO structure in the sub-directory named *NAMDIR*.

**DB-STRUC** **character\*12** keyword used to display the content of the *CPONAM* object for the *NAMDIR* directory.

### 3.14 The TLM: module

The TLM: module has been designed to generate a Matlab *m-file* (in an ASCII format) that contains the instructions for plotting the tracking lines generated by the NXT: module or by the SALT: module (LONG option).<sup>[94]</sup> The TLM: module is activated using the following list of commands:

Table 64: Structure (TLM:)

```
MFILE := TLM: MFILE TRKNAM TRKFIL :: (desctlm)
```

where

|                    |  |
|--------------------|--|
| <i>MFILE</i>       | <b>character*12</b> name of the ASCII Matlab <i>m-file</i> data structure that will contain the instructions for plotting the tracking lines.  |
| <i>TRKNAM</i>      | <b>character*12</b> name of the TRACKING data structure that will contain region volume and surface area vectors in addition to region identification pointers and other tracking information. |
| <i>TRKFIL</i>      | <b>character*12</b> name of the sequential binary tracking file used to store the tracks lengths. <sup>[104]</sup>   |
| ( <b>desctlm</b> ) | structure describing the type of graphics generated (see Section 3.14.1).  |

#### 3.14.1 Data input for module TLM:

Table 65: Structure (**desctlm**)

```
[ EDIT iprint ]
[ MIXTURE ]
[ NTPO nplots ]
( {
  POINTS [ NoPause ] |
  DIRECTIONS [ NoPause ] DIR idir [ PLAN iplan { U iuv | V iuv } ] |
  PLANP [ NoPause ] DIR idir DIST dist [ PLAN iplan ] |
  PLANA [ NoPause ] A a B b [ C c ] D d
} , iplot=1, nplots )
```

where

|               |   |
|---------------|---|
| EDIT          | keyword used to modify the print level <i>iprint</i> .  |
| <i>iprint</i> | index used to control the printing in this module. It must be set to 0 if no printing on the output file is required. |
| MIXTURE       | keyword to set drawing colors as a function of mixtures. By default, colors are set according to region indices.      |

|               |  |
|---------------|--|
| NTP0          | keyword to specify the number of figures to draw.  |
| <i>nplots</i> | integer value for the number of figures to draw.   |
| POINTS        | keyword to specify that the figure will illustrate the intersection points between the lines and the external faces of the geometry.   |
| DIRECTIONS    | keyword to specify that the figure will illustrate the lines crossing each region as well as the intersection points between the lines and the external faces of the geometry.   |
| PLANP         | keyword to specify that the figure will illustrate the points crossing a plane normal to the line direction.   |
| PLANA         | keyword to specify that the figure will illustrate the points crossing an arbitrary surface in 3-D or line in 2-D. The equation for the surface in 3-D is :  |
|               | $aX + bY + cZ = d$   |
|               | while the equation for the line in 2-D is :  |
|               | $aX + bY = d$  |
| NoPause       | keyword to specify that all the lines the lines must be drawn without Matlab pause. By default, there is a pause after all the points associated with an external surface and all the lines associated with a region are drawn.  |
| DIR           | keyword to specify line direction to draw.   |
| <i>idir</i>   | integer value to identify the track direction to draw. In the case where <i>idir</i> =0, all the directions will be drawn. A value of <i>idir</i> =0 for 2-D geometry is generally acceptable. However, for 3-D geometry the number of lines generated is such that the figure becomes a mess and it is generally more convenient to draw the lines direction per direction. |
| PLAN          | keyword to specify which of the three planes normal to the specified direction in 3-D will be considered for drawing. This plane is defined by the axes $U - V$ . Used only for 3-D geometries.  |
| <i>iplan</i>  | integer value to identify which of the three planes normal to the specified direction in 3-D will be considered for drawing. the only values permitted are 0, 1, 2 or 3. When a value of 0 is specified (default) all three planes will be drawn. Used only for 3-D geometries.  |
| U             | keyword to specify that the all the lines in the $V$ axis associated with a position on the $U$ axis will be drawn. Used only for 3-D geometries.  |
| V             | keyword to specify that the all the lines in the $U$ axis associated with a position on the $V$ axis will be drawn. Used only for 3-D geometries.  |
| <i>iuV</i>    | integer value to identify the position on the $U$ or $V$ axis to be drawn. Used only for 3-D geometries.   |
| DIST          | keyword to specify the distance between the plane normal to the line direction and the origin.   |
| <i>dist</i>   | real or double precision value for the distance of the plane from the origin.  |
| A             | keyword to specify the value of $a$ for an arbitrary plane or line.  |
| <i>a</i>      | real or double precision value $a$ .   |
| B             | keyword to specify the value of $b$ for an arbitrary plane or line.  |



- b* real or double precision value *b*.
- C* keyword to specify the value of *c* for an arbitrary plane.
- b* real or double precision value *c*.
- D* keyword to specify the value of *d* for an arbitrary plane or line.
- d* real or double precision value *d*.

### 3.15 The M2T: module

This component of the lattice code is dedicated to the generation of an ASCII file with the Apotrim specification using MACROLIB data. Such a file is useful to transfer multigroup and macroscopic cross-section data toward a Moret calculation.

The calling specifications are:

Table 66: Structure (M2T:)

```
APTRIM := M2T: [ APTRIM ] MLIB :: (M2T_data)
```

where

*APTRIM*      **character\*12** name of an ASCII file with the Apotrim specification. If *APTRIM* appears on the RHS, new information is appended to the existing Apotrim file.

*MLIB*        **character\*12** name of a MACROLIB (type L\_MACROLIB) object.

*M2T\_data*    input data structure containing specific data (see Section 3.15.1).

#### 3.15.1 Data input for module M2T:

Table 67: Structure (M2T\_data)

```
[ EDIT iprint ]
[ PN nl ] [ TRAN ] [ NOMA ]
[[ MIX hmix [ FROM imixold ] [ BURN bup ] [ TEMP tval ] ENDMIX ]]
;
```

where

**EDIT**        keyword used to set *iprint*.

*iprint*        index used to control the printing in module M2T:. =0 for no print; =1 for minimum printing (default value).

**PN**          keyword used to set the Legendre order of the scattering transfers written on the Apotrim file.

*nl*            Legendre order. By default, *nl* = 0 corresponding to an isotropic collision in LAB.

**TRAN**        keyword used to set a transport correction on cross sections written on the Apotrim file.

**NOMA**        keyword used to avoid writing the energy mesh on the Apotrim file. This option is useful to catenate additional mixture information on an existing Apotrim file. By default, the energy mesh is written on the Apotrim file.

**MIX**         keyword used to set *hmix*.



### 3.16 The CHAB: module

This component of the lattice code is dedicated to the modification of cross section information in a MICROLIB.

The calling specifications are:

Table 68: Structure (**CHAB:**)

```
{ MICRO1 | DRAGLIB1 } := CHAB: { MICRO1 | MICRO2 | DRAGLIB2 } :: (CHAB_data)
```

where

|                  |  |
|------------------|--|
| <i>MICRO1</i>    | <b>character*12</b> name of a MICROLIB (type L_LIBRARY) object that is created or modified by CHAB:. |
| <i>DRAGLIB1</i>  | <b>character*12</b> name of a DRAGLIB (type L_DRAGLIB) object that is created by CHAB:.              |
| <i>MICRO2</i>    | <b>character*12</b> name of a MICROLIB (type L_LIBRARY) object open in read-only mode.               |
| <i>DRAGLIB2</i>  | <b>character*12</b> name of a DRAGLIB (type L_DRAGLIB) object open in read-only mode.                |
| <i>CHAB_data</i> | input data structure containing specific data (see Section 3.16.1).                                  |

#### 3.16.1 Data input for module CHAB:

Table 69: Structure (**CHAB\_data**)

```
[ EDIT iprint ]  
[[ MODI TYPSEC igm TO igp { VALE [[ val ]] | CONS value | PLUS value | MULT value } HISOT ]] ;
```

where

|               |   |
|---------------|---|
| <b>EDIT</b>   | keyword used to set <i>iprint</i> .   |
| <i>iprint</i> | index used to control the printing in module CHAB:. =0 for no print; =1 for minimum printing (default value).   |
| <b>MODI</b>   | keyword used to define a modification of a nuclear reaction belonging to a given isotope.   |
| <i>TYPSEC</i> | <b>character*8</b> name of an existing nuclear reaction chosen among the following values:<br>'NTOTO' Total cross section.<br>'NG' Radiative capture cross section. The total ('NTOTO') cross section is modified accordingly.<br>'NA' ( $n, \alpha$ ) cross section. The total ('NTOTO') cross section is modified accordingly.<br>'NP' ( $n, p$ ) cross section. The total ('NTOTO') cross section is modified accordingly.<br>'ND' ( $n, d$ ) cross section. The total ('NTOTO') cross section is modified accordingly.<br>'NT' ( $n, t$ ) cross section. The total ('NTOTO') cross section is modified accordingly. |

|              |  |
|--------------|--|
|              | 'CAPT' Capture cross sections. Each present reaction of capture ( <b>NG</b> , <b>NA</b> , <b>NP</b> , <b>ND</b> , <b>NT</b> ) are taken into account. The total ('NTOTO') cross section is modified accordingly. Only the keyword <b>MULT</b> , indicating a multiplication of the all cross sections, is available. |
|              | 'NELAS' Elastic scattering cross section. The scattering ('SIGS00' and 'SCAT00') and total ('NTOTO') cross sections are modified accordingly.  |
|              | 'NINEL' Inelastic scattering cross section. The scattering ('SIGS00' and 'SCAT00') and total ('NTOTO') cross sections are modified accordingly.  |
|              | 'N2N' ( $n,2n$ ) cross section. The scattering ('SIGS00' and 'SCAT00') and total ('NTOTO') cross sections are modified accordingly.  |
|              | 'N3N' ( $n,3n$ ) cross section. The scattering ('SIGS00' and 'SCAT00') and total ('NTOTO') cross sections are modified accordingly.  |
|              | 'N4N' ( $n,4n$ ) cross section. The scattering ('SIGS00' and 'SCAT00') and total ('NTOTO') cross sections are modified accordingly.  |
|              | 'SIGS00', 'SIGS01', <b>etc.</b> Scattering cross section. The total ('NTOTO') cross section is modified accordingly.   |
|              | 'SCAT00', 'SCAT01', <b>etc.</b> Differential scattering cross section. The total ('NTOTO') cross section is modified accordingly.  |
|              | 'NUSIGF' $\nu$ times the fission cross section. The fission ('NFTOT') and total ('NTOTO') cross sections are modified accordingly.   |
|              | 'NFTOT' Fission cross section. The $\nu$ times fission ('NUSIGF') and total ('NTOTO') cross sections are modified accordingly.   |
|              | 'NU' Number of neutrons emitted per fission. The $\nu$ times fission ('NUSIGF') cross section is modified accordingly.   |
|              | 'CHI' Fission spectrum. The resulting spectrum is normalized.  |
| <i>igm</i>   | lower energy group index of the energy domain where the modification is taking place.  |
| <i>igp</i>   | upper energy group index of the energy domain where the modification is taking place.  |
| <b>VALE</b>  | keyword indicating a replacement of all values in the above energy domain by different values.   |
| <i>val</i>   | group-dependent real variable used as replacement value. We expect $igp-igm+1$ components.   |
| <b>CONS</b>  | keyword indicating a replacement of all values in the above energy domain by <i>value</i> .  |
| <b>PLUS</b>  | keyword indicating that <i>value</i> is added to all values in the above energy domain.  |
| <b>MULT</b>  | keyword indicating a multiplication of all values in the above energy domain by <i>value</i> .   |
| <i>value</i> | real variable used to modify the nuclear reaction.   |
| <b>HISOT</b> | <b>character*8</b> or <b>character*12</b> name of the isotope to modify. If <b>HISOT</b> is a <b>character*8</b> value, all <b>character*12</b> isotope names prefixed by <b>HISOT</b> are modified.   |

### 3.17 The CPO: module

The CPO: module is used to generate the reactor cross-section database in Version3 format to be used in a full core calculation using DONJON. This type of database is only parametrized in burnup (or irradiation). The calling specifications are:

Table 70: Structure (CPO:)

*CPONAM* := CPO: [ *CPONAM* ] *EDINAM* [ *BRNNAM* ] :: (desccpo)

where

|               |   |
|---------------|---|
| <i>CPONAM</i> | <b>character*12</b> name of the CPO data structure containing the reactor database. Additional contributions can be included in the reactor cross-section database if <i>CPONAM</i> appears on the RHS. |
| <i>EDINAM</i> | <b>character*12</b> name of the read-only EDITION data structure.   |
| <i>BRNNAM</i> | <b>character*12</b> name of the read-only BURNUP data structure containing the depletion history. This information is given only if the reactor database is to contain burnup dependent data.           |
| (desccpo)     | structure containing the input data to this module (see Section 3.17.1).  |

#### 3.17.1 Data input for module CPO:

Table 71: Structure (desccpo)

```
[ EDIT iprint ]
[ B2 ] [ NOTR ]
{ STEP NOMDIR | BURNUP PREFIX }
[ [ EXTRACT { ALL | NEWNAME (OLDNAME(i), i=1,niext) } ] ]
[ NAME NDIR ]
[ { GLOB | LOCA } ]
```

where

|               |   |
|---------------|---|
| EDIT          | keyword used to modify the print level <i>iprint</i> .  |
| <i>iprint</i> | index used to control the printing of this module. The amount of output produced by this tracking module will vary substantially depending on the print level specified.  |
| B2            | keyword to specify that the buckling correction ( $dB^2$ ) is to be applied to the cross section to be stored on the reactor database. By default (fixed default), such a correction is not taken into account. |
| NOTR          | keyword to specify that the cross section to be stored on the reactor database are not to be transport corrected. By default (fixed default), transport corrected cross section                                 |

are considered when the CTRA option is activated in MAC: or LIB: (see Sections 3.1 and 3.2).

|         |   |
|---------|---|
| STEP    | keyword to specify that a specific cross section directory stored in <i>EDINAM</i> via the SAVE option in the EDI: module is to be transferred to <i>CPONAM</i> .   |
| NOMDIR  | character*12 name of the specific cross section directory to be treated.  |
| BURNUP  | keyword to specify that a chain of cross section directory stored in <i>EDINAM</i> via the SAVE option in the EDI: module will be transferred to <i>CPONAM</i> .  |
| PREFIX  | character*8 prefix name of the cross section directory to be treated. DRAGON will transfer into the reactor database all the directories with full name NAMDIR created using <pre style="margin-left: 40px;">WRITE(NAMDIR, '(A8,I4)') PREFIX,nb</pre> where nb is an integer greater than 0 indicating the depletion step index.                    |
| EXTRACT | keyword to specify that the contribution of some isotopes to the macroscopic cross sections associated with each homogenized mixture should be extracted before being stored on the reactor database. The microscopic cross sections and concentrations associated with these isotopes should also be generated and stored on the reactor database. |
| ALL     | keyword to specify that all the isotopes processed using the MICR option of the EDI: module should be extracted from the macroscopic cross sections associated with each homogenized mixture.   |
| NEWNAME | character*12 name under which a given set of extracted isotope will be stored on the reactor database.  |
| OLDNAME | array of character*8 name of isotopes to be extracted from the macroscopic cross section associated with each homogenized mixture.  |
| NAME    | keyword to specify the prefix for the name of the sub-directory where the information corresponding to a single homogenized region will be stored. The fixed default is <i>NDIR='COMPO~~~'</i> .  |
| NDIR    | character*8 prefix for the name of the sub-directory. The complete name is constructed by the concatenation of <i>NDIR</i> with a four digit integer value.   |
| GLOB    | keyword to specify that global parameters are used to index the database (default option). A global parameter is defined over the complete calculation domain.  |
| LOCA    | keyword to specify that local parameters are used to index the database. A local parameter is defined over each homogenization mixture.   |

### 3.18 The SAP: module

This component of the lattice code is dedicated to the constitution of the reactor database intended to store *all* the nuclear data, produced in the lattice code, that is useful in reactor calculations including fuel management and space-time kinetics. Multigroup lattice calculations are too expensive to be executed dynamically from the driver of the global reactor calculation. A more feasible approach is to create a reactor database where a finite number of lattice calculation results are tabulated against selected *global parameters* chosen so as to represent expected operating conditions of the reactor.

The SAP: operator is used to create and construct a SAPHYB object. This object is generally *persistent* and used to collect information gathered from many DRAGON *elementary calculations* performed under various conditions. The SAPHYB object is based on a specification of the Saphyr code system.<sup>[9]</sup>

Each elementary calculation is characterized by a tuple of *global parameters*. These global parameters are of different types, depending on the nature of the study under consideration: type of assembly, power, temperature in a mixture, concentration of an isotope, time, burnup or exposure rate in a depletion calculation, etc. Each step of a depletion calculation represents an elementary calculation. The SAPHYB object is often presented as a *multi-parameter reactor database*.

For each elementary calculation, the results are recovered from the output of the EDI: operator and stored in a set of *homogenized mixture* directories. The EDI: operator is responsible for performing condensation in energy and homogenization in space of the macroscopic and microscopic cross sections. All the elementary calculations gathered in a single SAPHYB object are characterized by a single output geometry and a unique output energy-group structure.

The SAPHYB object contains table-of-content information apart from a set of specific *elementary calculation* directories. These directories are themselves subdivided into *homogenized mixture* directories. The localization of an elementary calculation is done using a tuple of global parameters. The elementary calculation indices are stored in a tree with the number of levels equal to the number of global parameters. An example of a tree with three global parameters is shown in Figure 22. Each node of this tree is associated with the index of the corresponding global parameter and with the reference to the daughter nodes if they exist. The number of leaves is equal to the number of nodes for the last (third) parameter and is equal to the number of elementary calculations stored in the SAPHYB object. The index of each elementary calculation is therefore an attribute of each leaf.

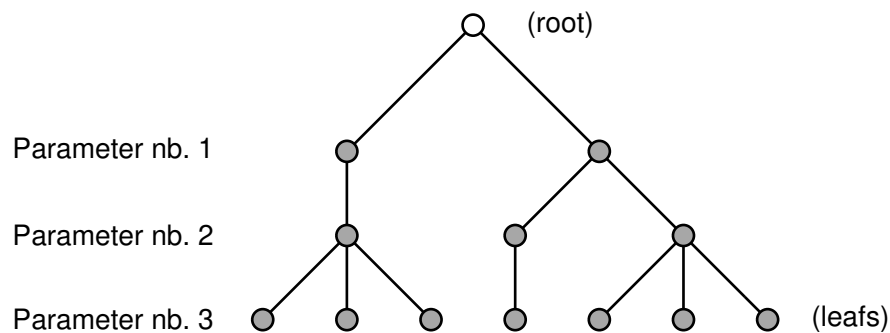

Figure 22: Global parameter tree in a SAPHYB object

In each homogenized mixture directory, the SAP: operator recover cross sections for a number of *particularized isotopes* and *macroscopic sets*, a collection of isotopic cross sections weighted by isotopic number densities. Cross sections for particularized isotopes and macroscopic sets are recovered for *selected reactions*. Other information is also recovered: multigroup neutron fluxes, isotopic number densities, fission spectrum and a set of *local variables*. The local variables are values that characterize each homogenized mixture: local power, burnup, exposure rate, etc. Some local variables are arrays of values (eg: SPH equivalence factors). Finally, note that cross section information written on the SAPHYB is *not* transport corrected and *not* SPH corrected.

A different specification of the SAP: function call is used for creation and construction of the SAPHYB object.



- The first specification is used to initialize the SAPHYB data structure as a function of the MICROLIB used in the reference calculation. Optionnally, the homogenized geometry is also provided. The initialization call is also used to set the choice of global parameters, local variables, particularized isotopes, macroscopic sets and selected reactions.
- A modification call to the `SAP:` function is performed after each elementary calculation in order to recover output information processed by EDI: (condensed and homogenized cross sections) and EVO: (burnup dependant values). Global parameters and local variables can optionnally be recovered from MICROLIB objects. The EDI: calculation is generally performed with option `MICR ALL`.

The calling specifications are:

Table 72: Structure (**SAP:**)

```
{ SAPNAM := SAP: [ SAPNAM ] [ HMIC ] :: (saphyb_data1)
  | SAPNAM := SAP: SAPNAM EDINAM [ BRNNAM ] [ HMIC1 [ HMIC2 ] ] [ FLUNAM ]
  :: (saphyb_data2)
  | SAPNAM := SAP: SAPNAM SAPRHS :: (saphyb_data3) }
```

where

|                     |  |
|---------------------|--|
| <i>SAPNAM</i>       | <b>character*12</b> name of the LCM object containing the <i>master</i> SAPHYB data structure.   |
| <i>HMIC</i>         | <b>character*12</b> name of the reference MICROLIB (type <code>L_LIBRARY</code> ) containing the microscopic cross sections.   |
| <i>EDINAM</i>       | <b>character*12</b> name of the LCM object (type <code>L_EDIT</code> ) containing the EDITION data structure corresponding to an elementary calculation. The EDITION data produced by the last call to the <code>EDI:</code> module is used.   |
| <i>BRNNAM</i>       | <b>character*12</b> name of the LCM object (type <code>L_BURNUP</code> ) containing the BURNUP data structure. This object is compulsory if one of the following parameters is used: <code>IRRA</code> , <code>FLUB</code> and/or <code>TIME</code> .  |
| <i>HMIC1</i>        | <b>character*12</b> name of a MICROLIB (type <code>L_LIBRARY</code> ) containing global parameter information.   |
| <i>HMIC2</i>        | <b>character*12</b> name of a MICROLIB (type <code>L_LIBRARY</code> ) containing global parameter information.   |
| <i>FLUNAM</i>       | <b>character*12</b> name of the reference FLUX (type <code>L_FLUX</code> ). By default, the reference flux is not recovered and not written on the SAPHYB.   |
| <i>SAPRHS</i>       | <b>character*12</b> name of the <i>read-only</i> SAPHYB data structure. This data structure is concatenated to <i>SAPNAM</i> using the <i>saphyb_data3</i> data structure, as presented in Section 3.18.3. <i>SAPRHS</i> must be defined with the same number of energy groups and the same number of homogeneous regions as <i>SAPNAM</i> . Moreover, all the global and local parameters of <i>SAPRHS</i> must be defined in <i>SAPNAM</i> . <i>SAPNAM</i> may be defined with <i>global</i> parameters not defined in <i>SAPRHS</i> . |
| <i>saphyb_data1</i> | input data structure containing initialization information (see Section 3.18.1).   |
| <i>saphyb_data2</i> | input data structure containing information related to the recovery of an elementary calculation (see Section 3.18.2).   |
| <i>saphyb_data3</i> | input data structure containing information related to the catenation of a <i>read-only</i> SAPHYB (see Section 3.18.3).   |

## 3.18.1 Initialization data input for module SAP:

Table 73: Structure (**saphyb\_data1**)

```

[ EDIT iprint ]
[ NOML nomlib ]
[ COMM [[ comment ]] ENDC ]
[[ PARA parnam parkey
  { TEMP micnam imix | CONC isonam1 micnam imix | IRRR | FLUB |
    PUIS | MASL | FLUX | TIME | VALE { FLOT | CHAI | ENTI } }
]]
[[ LOCA parnam parkey
  { TEMP | CONC isonam2 | IRRR | FLUB | FLUG | PUIS | MASL | FLUX | EQUI }
]]
[ ISOT { TOUT | MILI imil | [ FISS ] [ PF ] [ (HNAISO(i), i=1,Niso) ] } ]
[[ MACR HNAMAC { TOUT | REST } ]]
[ REAC (HNAREA(i), i=1,Nreac) ]
[ NAME (HNAMIX(i), i=1,Nm) ]
;
```

where

|                |   |
|----------------|---|
| EDIT           | key word used to set <i>iprint</i> .  |
| <i>iprint</i>  | index used to control the printing in module SAP: . =0 for no print; =1 for minimum printing (default value).   |
| NOML           | key word used to input a user-defined name for the SAPHYB. This information is mandatory if the Saphyb is to be read by the Lisaph module of Cronos.                                |
| <i>nomlib</i>  | character*80 user-defined name.   |
| COMM           | key word used to input a general comment for the SAPHYB.  |
| <i>comment</i> | character*80 user-defined comment.  |
| ENDC           | end-of-comment key word.  |
| PARA           | keyword used to define a single global parameter.   |
| LOCA           | keyword used to define a single local variable (a local variable may be a single value or an array of values).  |
| <i>parnam</i>  | character*80 user-defined name of a global parameter or local variable.   |
| <i>parkey</i>  | character*4 user-defined keyword associated to a global parameter or local variable.  |
| <i>micnam</i>  | character*12 name of the MICROLIB (type L_LIBRARY) associated to a global parameter. The corresponding MICROLIB will be required on RHS of the SAP: call described in Sect. 3.18.2. |
| <i>imix</i>    | index of the mixture associated to a global parameter. This mixture is located in MICROLIB named <i>micnam</i> .  |
| <i>isonam1</i> | character*8 alias name of the isotope associated to a global parameter. This isotope is located in MICROLIB data structure named <i>micnam</i> .                                    |

|                  |   |
|------------------|---|
| <i>isonam2</i>   | <b>character*8</b> alias name of the isotope associated to a local variable. This isotope is located in the MICROLIB directory of the EDITION data structure named <i>EDINAM</i> .  |
| TEMP             | keyword used to define a temperature (in °C) as global parameter or local variable.   |
| CONC             | keyword used to define a number density as global parameter or local variable.  |
| IRRA             | keyword used to define a burnup (in MWday/Tonne) as global parameter or local variable.   |
| FLUB             | keyword used to define a <i>fuel-only</i> exposure rate (in n/kb) as global parameter or local variable. The exposure rate is recovered from the <i>BRNNAM</i> LCM object.  |
| FLUG             | keyword used to define an exposure rate in global homogenized mixtures (in n/kb) as local variable. The exposure rate is recovered from the <i>BRNNAM</i> LCM object.   |
| PUIS             | keyword used to define the power as global parameter or local variable.   |
| MASL             | keyword used to define the mass density of heavy isotopes as global parameter or local variable.  |
| FLUX             | keyword used to define the volume-averaged, energy-integrated flux as global parameter or local variable.   |
| TIME             | keyword used to define the time (in seconds) as global parameter.   |
| EQUI             | keyword used to define the SPH equivalence factors as local variable. A set of SPH factors can be defined as local variables. Note that the cross sections and fluxes stored in the <i>SAPHYB</i> are <i>not</i> SPH corrected. |
| VALE             | keyword used to define a user-defined quantity as global parameter. This keyword must be followed by the type of parameter.   |
| FLOT             | keyword used to indicate that the user-defined global parameter is a floating point value.  |
| CHAI             | keyword used to indicate that the user-defined global parameter is a <b>character*12</b> value.   |
| ENTI             | keyword used to indicate that the user-defined global parameter is an integer value.  |
| ISOT             | keyword used to select the set of particularized isotopes.  |
| TOUT             | keyword used to select all the available isotopes in the reference MICROLIB named <i>HMIC</i> as particularized isotopes.   |
| MILI             | keyword used to select the isotopes in the reference MICROLIB named <i>HMIC</i> from a specific mixture as particularized isotopes.   |
| <i>imil</i>      | index of the mixture where the particularized isotopes are recovered.   |
| FISS             | keyword used to select all the available fissile isotopes in the reference MICROLIB named <i>HMIC</i> as particularized isotopes.   |
| PF               | keyword used to select all the available fission products in the reference MICROLIB named <i>HMIC</i> as particularized isotopes.   |
| <i>HNAISO(i)</i> | <b>character*12</b> user-defined isotope name. $N_{\text{iso}}$ is the total number of explicitly-selected particularized isotopes.   |
| MACR             | keyword used to select a type of macroscopic set. A maximum of two macroscopic sets is allowed.   |
| <i>HNAMAC</i>    | <b>character*8</b> user-defined name of the macroscopic set.  |

|                   |  |
|-------------------|--|
| TOUT              | keyword used to select all the available isotopes in the macroscopic set.  |
| REST              | keyword used to remove all the particularized isotope contributions from the macroscopic set.  |
| REAC              | keyword used to select the set of nuclear reactions.   |
| <i>HNAREA</i> (i) | <p><b>character*4</b> name of a user-selected reaction. <math>N_{\text{reac}}</math> is the total number of selected reactions. <i>HNAREA</i>(i) is chosen among the following values:</p> <p>TOTA Total cross sections<br/> TOP1 Total <math>P_1</math>-weighted cross sections<br/> ABSO Absorption cross sections<br/> SNNN Excess cross section due to (n,xn) reactions<br/> FISS Fission cross section<br/> CHI Steady-state fission spectrum<br/> NUFI <math>\nu\Sigma_f</math> cross sections<br/> ENER Energy production cross section, taking into account all energy production reactions<br/> EFIS Energy production cross section for (n,f) reaction only<br/> EGAM Energy production cross section for (n,<math>\gamma</math>) reaction only<br/> FUIT <math>B^2</math> times the leakage coefficient<br/> SELF within-group <math>P_0</math> scattering cross section<br/> DIFF scattering cross section for each available Legendre order. These cross sections are <i>not</i> multiply by the <math>2\ell + 1</math> factor.<br/> PROF profile of the transfer cross section matrices (i.e. position of the non-zero element in the transfer cross section matrices)<br/> TRAN transfer cross section matrices for each available Legendre order. These cross sections are multiply by the <math>2\ell + 1</math> factor.<br/> CORR transport correction. Note that the cross sections stored in the SAPHYB are <i>not</i> transport corrected.<br/> STRD STRD cross sections used to compute the diffusion coefficients<br/> NP (n,p) production cross sections<br/> NT (n,t) production cross sections<br/> NA (n,<math>\alpha</math>) production cross sections</p> |
| NAME              | <p>key word used to define mixture names. By default, mixtures names are of the form <i>HNAMIX</i>(i), where</p> <pre>WRITE(HNAMIX(I), '(3HMIX,I5.5)') I</pre>   |
| <i>HNAMIX</i> (i) | Character*20 user-defined mixture name. $N_m$ is the number of mixtures.   |

### 3.18.2 Modification data input for module SAP:

Table 74: Structure (**saphyb\_data2**)

```
[ EDIT iprint ]
[ CRON ]
[[ parkey value ]]
[ ORIG orig ]
[ SET xtr { S | DAY | YEAR } ]
;
```

where

|               |  |
|---------------|--|
| EDIT          | key word used to set <i>iprint</i> .   |
| <i>iprint</i> | index used to control the printing in module SAP:. =0 for no print; =1 for minimum printing (default value).   |
| CRON          | key word used to force the kinetics data to be placed into the <b>divers</b> directory. By default, the kinetics data is placed in the <b>cinetique</b> directory of each mixture subdirectory. The CRON option can only be used if the Saphyb contains a unique mixture. This option is mandatory if the Saphyb is to be read by the Lisaph module of Cronos. |
| <i>parkey</i> | <b>character*4</b> keyword associated to a user-defined global parameter.  |
| <i>value</i>  | floating-point, integer or <b>character*12</b> value of a user-defined global parameter.   |
| ORIG          | key word used to define the father node in the global parameter tree. By default, the index of the previous elementary calculation is used.  |
| <i>orig</i>   | index of the elementary calculation associated to the father node in the global parameter tree.  |
| SET           | keyword used to recover the flux normalization factor already stored on <i>BRNNAM</i> from a sub-directory corresponding to a specific time.   |
| <i>xtr</i>    | time associated with the current flux calculation. The name of the sub-directory where this information is stored will be given by 'DEPL-DAT'//CNN where CNN is a <b>character*4</b> variable defined by WRITE(CNN,'(I4)') INN where INN is an index associated with the time <i>xtr</i> .   |
| S             | keyword to specify that the time is given in seconds.  |
| DAY           | keyword to specify that the time is given in days.   |
| YEAR          | keyword to specify that the time is given in years.  |

### 3.18.3 Modification (*catenate*) data input for module SAP:

Table 75: Structure (**saphyb\_data3**)

```
[ EDIT iprint ]
[ ORIG orig ]
[[ parkey value ]]
[ WARNING-ONLY ]
;
```

where

|               |  |
|---------------|--|
| EDIT          | keyword used to set <i>iprint</i> .  |
| <i>iprint</i> | index used to control the printing in module SAP:. =0 for no print; =1 for minimum printing (default value).                   |
| <i>parkey</i> | <b>character*4</b> keyword associated to a global parameter that is specific to <i>SAPNAM</i> (not defined in <i>SAPRHS</i> ). |

|                     |  |
|---------------------|--|
| <i>value</i>        | floating-point, integer or <b>character*12</b> value of a user-defined global parameter.   |
| <b>ORIG</b>         | keyword used to define the father node in the parameter tree. By default, the index of the previous elementary calculation is used.  |
| <i>orig</i>         | index of the elementary calculation associated to the father node in the parameter tree.   |
| <b>WARNING-ONLY</b> | This option is useful if an elementary calculation in <i>SAPRHS</i> is already present in <i>SAPNAM</i> . If this keyword is set, a warning is send and the <i>SAPNAM</i> values are kept, otherwise the run is aborted (default). |

### 3.19 The MPO: module

This component of the lattice code is dedicated to the constitution of the reactor database in MPO format, similar to the file produced by APOLO3.<sup>[10]</sup> The MPO file intended to store *all* the nuclear data, produced in the lattice code, that is useful in reactor calculations including fuel management and space-time kinetics. Multigroup lattice calculations are too expensive to be executed dynamically from the driver of the global reactor calculation. A more feasible approach is to create a reactor database where a finite number of lattice calculation results are tabulated against selected *global parameters* chosen so as to represent expected operating conditions of the reactor. The MPO: operator is used to create and construct a MPO file. The MPO file is written in HDF5 format, allowing full portability and hierarchical data organization. It can be edited and modified using the HDFView tool.

Each elementary calculation is characterized by a tuple of *global parameters*. These global parameters are of different types, depending on the nature of the study under consideration: type of assembly, power, temperature in a mixture, concentration of an isotope, time, burnup or exposure rate in a depletion calculation, etc. Each step of a depletion calculation represents an elementary calculation. The MPO file is often presented as a *multi-parameter reactor database*.

For each elementary calculation, the results are recovered from the output of the EDI: operator and stored in a set of *homogenized mixture* directories. The EDI: operator is responsible for performing condensation in energy and homogenization in space of the macroscopic and microscopic cross sections. All the elementary calculations gathered in a single MPO file are characterized by a single output geometry and a unique output energy-group structure. The MPO file may contain many geometry/energy-group combinations.

In each homogenized mixture directory, the MPO: operator recover cross sections for a number of *particularized isotopes* and *macroscopic residual sets*, a collection of isotopic cross sections weighted by isotopic number densities. Cross sections for particularized isotopes and macroscopic sets are recovered for *selected reactions*. Other information is also recovered: multigroup neutron fluxes, isotopic number densities, fission spectrum and a set of *local variables*. The local variables are values that characterize each homogenized mixture: local power, burnup, exposure rate, etc. Some local variables are arrays of values (eg: SPH equivalence factors). Discontinuity factors and equivalent albedos are written in group **flux**, as described in Sect. 3.19.4. Finally, note that cross section information written on the MPO file is *not* transport corrected and *not* SPH corrected.

A different specification of the MPO: function call is used for creation and construction of the MPO file.

- The first specification is used to initialize the MPO data structure as a function of the MICROLIB used in the reference calculation. Optionnally, the homogenized geometry is also provided. The initialization call is also used to set the choice of global parameters, local variables, particularized isotopes, macroscopic sets and selected reactions.
- A modification call to the MPO: function is performed after each elementary calculation in order to recover output information processed by EDI: (condensed and homogenized cross sections) and EVO: (burnup dependant values). Global parameters and local variables can optionnally be recovered from MICROLIB objects. The EDI: calculation is generally performed with option MICR ALL.

The calling specifications are:

Table 76: Structure (MPO:)

```
{ MPONAM := MPO: [ MPONAM ] [ HMIC ] :: (mpo_data1)
  | MPONAM := MPO: MPONAM EDINAM [ BRNNAM ] [ HMIC1 [ HMIC2 ] ] :: (mpo_data2)
  | MPONAM := MPO: MPONAM MPORHS :: (mpo_data3) }
```

where

**MPONAM**      **character\*12** name of the LCM object containing the *master* MPO data structure.

|                  |  |
|------------------|--|
| <i>HMIC</i>      | <code>character*12</code> name of the reference MICROLIB (type <code>L_LIBRARY</code> ) containing the microscopic cross sections.   |
| <i>EDINAM</i>    | <code>character*12</code> name of the LCM object (type <code>L_EDIT</code> ) containing the EDITION data structure corresponding to an elementary calculation. The EDITION data produced by the last call to the <code>EDI:</code> module is used.   |
| <i>BRNNAM</i>    | <code>character*12</code> name of the LCM object (type <code>L_BURNUP</code> ) containing the BURNUP data structure. This object is compulsory if one of the following parameters is used: <code>IRRA</code> , <code>FLUB</code> and/or <code>TIME</code> .  |
| <i>HMIC1</i>     | <code>character*12</code> name of a MICROLIB (type <code>L_LIBRARY</code> ) containing global parameter information.   |
| <i>HMIC2</i>     | <code>character*12</code> name of a MICROLIB (type <code>L_LIBRARY</code> ) containing global parameter information.   |
| <i>MPORHS</i>    | <code>character*12</code> name of the <i>read-only</i> MPO data structure. This data structure is concatenated to <i>MPONAM</i> using the <i>mpo_data3</i> data structure, as presented in Section 3.19.3. <i>MPORHS</i> must be defined with the same number of energy groups and the same number of homogeneous regions as <i>MPONAM</i> . Moreover, all the global and local parameters of <i>MPORHS</i> must be defined in <i>MPONAM</i> . <i>MPONAM</i> may be defined with <i>global</i> parameters not defined in <i>MPORHS</i> . |
| <i>mpo_data1</i> | input data structure containing initialization information (see Section 3.19.1).   |
| <i>mpo_data2</i> | input data structure containing information related to the recovery of an elementary calculation (see Section 3.19.2).   |
| <i>mpo_data3</i> | input data structure containing information related to the catenation of a <i>read-only</i> MPO file (see Section 3.19.3).   |



## 3.19.1 Initialization data input for module MPO:

Table 77: Structure (**mpo\_data1**)

```

[ EDIT iprint ]
[ COMM comment ]
[[ PARA parkey
  { TEMP micnam imix | CONC isonam1 micnam imix | IRRRA | FLUB |
    PUIS | MASL | FLUX | TIME | VALU { REAL | CHAR | INTE } }
]]
[[ LOCA parkey
  { TEMP | CONC isonam2 | IRRRA | FLUB | FLUG | PUIS | MASL | FLUX | EQUI }
]]
[ ISOT { TOUT | MILI imil | [ FISS ] [ PF ] [ (HNAISO(i), i=1,Niso) ] } ]
[ REAC (HNAREA(i), i=1,Nreac) ]
;
```

where

|                |   |
|----------------|---|
| EDIT           | keyword used to set <i>iprint</i> .   |
| <i>iprint</i>  | index used to control the printing in module MPO: . =0 for no print; =1 for minimum printing (default value).   |
| COMM           | keyword used to input a general comment for the MPO file.   |
| <i>comment</i> | character*132 user-defined comment.   |
| PARA           | keyword used to define a single global parameter.   |
| LOCA           | keyword used to define a single local variable (a local variable may be a single value or an array of values).  |
| <i>parkey</i>  | character*24 user-defined keyword associated to a global parameter or local variable.   |
| <i>micnam</i>  | character*12 name of the MICROLIB (type L.LIBRARY) associated to a global parameter. The corresponding MICROLIB will be required on RHS of the MPO: call described in Sect. 3.19.2. |
| <i>imix</i>    | index of the mixture associated to a global parameter. This mixture is located in MICROLIB named <i>micnam</i> .  |
| <i>isonam1</i> | character*8 alias name of the isotope associated to a global parameter. This isotope is located in MICROLIB data structure named <i>micnam</i> .                                    |
| <i>isonam2</i> | character*8 alias name of the isotope associated to a local variable. This isotope is located in the MICROLIB directory of the EDITION data structure named <i>EDINAM</i> .         |
| TEMP           | keyword used to define a temperature (in Kelvin) as global parameter or local variable.   |
| CONC           | keyword used to define a number density as global parameter or local variable.  |
| IRRA           | keyword used to define a burnup (in MWday/Tonne) as global parameter or local variable.   |

|                  |  |
|------------------|--|
| FLUB             | keyword used to define a <i>fuel-only</i> exposure rate (in n/kb) as global parameter or local variable. The exposure rate is recovered from the <i>BRNNAM</i> LCM object.   |
| FLUG             | keyword used to define an exposure rate in global homogenized mixtures (in n/kb) as local variable. The exposure rate is recovered from the <i>BRNNAM</i> LCM object.  |
| PUIS             | keyword used to define the power as global parameter or local variable.  |
| MASL             | keyword used to define the mass density of heavy isotopes as global parameter or local variable.   |
| FLUX             | keyword used to define the volume-averaged, energy-integrated flux as global parameter or local variable.  |
| TIME             | keyword used to define the time (in seconds) as global parameter.  |
| EQUI             | keyword used to define the SPH equivalence factors as local variable. A set of SPH factors can be defined as local variables. Note that the cross sections and fluxes stored in the MPO file are <i>not</i> SPH corrected. |
| VALU             | keyword used to define a user-defined quantity as global parameter. This keyword must be followed by the type of parameter.  |
| REAL             | keyword used to indicate that the user-defined global parameter is a floating point value.   |
| CHAR             | keyword used to indicate that the user-defined global parameter is a <code>character*12</code> value.  |
| INTE             | keyword used to indicate that the user-defined global parameter is an integer value.   |
| ISOT             | keyword used to select the set of particularized isotopes. The macroscopic residual ' <code>TotalResidual_mix</code> ' is always included as the last isotope in the list.   |
| TOUT             | keyword used to select all the available isotopes in the reference MICROLIB named <i>HMIC</i> as particularized isotopes.  |
| MILI             | keyword used to select the isotopes in the reference MICROLIB named <i>HMIC</i> from a specific mixture as particularized isotopes.  |
| <i>imil</i>      | index of the mixture where the particularized isotopes are recovered.  |
| FISS             | keyword used to select all the available fissile isotopes in the reference MICROLIB named <i>HMIC</i> as particularized isotopes.  |
| PF               | keyword used to select all the available fission products in the reference MICROLIB named <i>HMIC</i> as particularized isotopes.  |
| <i>HNAISO(i)</i> | <code>character*12</code> user-defined isotope name. $N_{\text{iso}}$ is the total number of explicitly-selected particularized isotopes.  |
| REAC             | keyword used to select the set of nuclear reactions. By default, the following reactions are selected:   |

|                      |   |
|----------------------|---|
| Total                | Total cross sections as $\sigma_g^{\text{absorption}} + \sigma_{0,g}^{\text{diffusion}}$  |
| Absorption           | Absorption cross sections $\sigma_g^{\text{absorption}}$  |
| Diffusion            | Scattering cross section for each available Legendre order $\sigma_{\ell,g}^{\text{diffusion}}$ . These cross sections are <i>not</i> multiply by the $2\ell + 1$ factor.                               |
| Fission              | Fission cross section   |
| FissionSpectrum      | Steady-state fission spectrum   |
| Nexcess              | Excess cross section due to (n,xn) reactions  |
| NuFission            | $\nu\Sigma_f$ cross sections  |
| Scattering           | Scattering reaction as $\sigma_{\ell,g \rightarrow g'} = \sigma_{\ell,g \rightarrow g'}^{\text{elastic}} + \sigma_{\ell,g \rightarrow g'}^{\text{inelastic}} + \sigma_{\ell,g \rightarrow g'}^{(n,xn)}$ |
| CaptureEnergyCapture | Energy production cross section for (n, $\gamma$ ) reaction only  |
| FissionEnergyFission | Energy production cross section for (n,f) reaction only   |

**HNAREA**

character\*20 name of a user-selected reaction in addition to default set. *HNAREA* is selected among the following values:

|                     |   |
|---------------------|---|
| TotalP1             | Total $P_1$ -weighted cross sections  |
| ElasticDiffusion    | Elastic scattering cross section for each available Legendre order                |
| InelasticDiffusion  | Inelastic scattering cross section for each available Legendre order              |
| NxnDiffusion        | (n,xn) scattering cross section for each available Legendre order                 |
| ElasticScattering   | Elastic scattering reaction $\sigma_{\ell,g \rightarrow g'}^{\text{elastic}}$     |
| InelasticScattering | Inelastic scattering reaction $\sigma_{\ell,g \rightarrow g'}^{\text{inelastic}}$ |
| NxnScattering       | (n,xn) scattering reaction $\sigma_{\ell,g \rightarrow g'}^{(n,xn)}$              |
| MT16                | (n,2n) production cross sections  |
| MT17                | (n,3n) production cross sections  |
| MT28                | (n,np) production cross sections  |
| MT37                | (n,4n) production cross sections  |
| MT103               | (n,p) production cross sections   |
| MT104               | (n,d) production cross sections   |
| MT105               | (n,t) production cross sections   |
| MT107               | (n, $\alpha$ ) production cross sections  |
| MT108               | (n,2 $\alpha$ ) production cross sections   |
| Capture             | (n, $\gamma$ ) production cross sections  |

## 3.19.2 Modification data input for module MPO:

Table 78: Structure (**mpo\_data2**)

```
[ EDIT iprint ]
[ STEP NAMDIR ]
[[ parkey value ]]
[ SET xtr { S | DAY | YEAR } ]
;
```

where

**EDIT** keyword used to set *i*print.

*i*print index used to control the printing in module MPO: . =0 for no print; =1 for minimum printing (default value).

|               |  |
|---------------|--|
| STEP          | keyword used to access the MPO database from a group named <i>NAMDIR</i> . The default value is 'output_0'.  |
| <i>NAMDIR</i> | access the MPO database in the group named <i>NAMDIR</i> . This name is the concatenation of prefix 'output_' with an integer $\geq 0$ .   |
| <i>parkey</i> | <b>character*24</b> keyword associated to a user-defined global parameter.   |
| <i>value</i>  | floating-point, integer or <b>character*12</b> value of a user-defined global parameter.   |
| SET           | keyword used to recover the flux normalization factor already stored on <i>BRNNAM</i> from a sub-directory corresponding to a specific time.   |
| <i>xtr</i>    | time associated with the current flux calculation. The name of the sub-directory where this information is stored will be given by 'DEPL-DAT'// <i>CNN</i> where <i>CNN</i> is a <b>character*4</b> variable defined by <code>WRITE(CNN,'(I4)')</code> <i>INN</i> where <i>INN</i> is an index associated with the time <i>xtr</i> . |
| S             | keyword to specify that the time is given in seconds.  |
| DAY           | keyword to specify that the time is given in days.   |
| YEAR          | keyword to specify that the time is given in years.  |

### 3.19.3 Modification (catenate) data input for module MPO:

Table 79: Structure (**mpo\_data3**)

```
[ EDIT iprint ]
[ STEP NAMDIR ]
[[ parkey value ]]
[ WARNING-ONLY ]
;
```

where

|               |  |
|---------------|--|
| EDIT          | keyword used to set <i>iprint</i> .  |
| <i>iprint</i> | index used to control the printing in module MPO: . =0 for no print; =1 for minimum printing (default value).  |
| STEP          | keyword used to access the MPO database from a group named <i>NAMDIR</i> . The default value is 'output_0'.  |
| <i>NAMDIR</i> | access the MPO database in the group named <i>NAMDIR</i> . This name is the concatenation of prefix 'output_' with an integer $\geq 0$ .   |
| <i>parkey</i> | <b>character*24</b> keyword associated to a global parameter that is specific to <i>MPONAM</i> (not defined in <i>MPORHS</i> ).  |
| <i>value</i>  | floating-point, integer or <b>character*12</b> value of a user-defined global parameter.   |
| WARNING-ONLY  | This option is useful if an elementary calculation in <i>MPORHS</i> is already present in <i>MPONAM</i> . If this keyword is set, a warning is send and the <i>MPONAM</i> values are kept, otherwise the run is aborted (default). |

## 3.19.4 Specification of discontinuity factor and equivalent albedo information

Discontinuity factors and equivalent albedos are written in group `flux` included in each state point group of the MPO file. Specification of some datasets in group `flux` are slightly modified to hold this new information:

Table 80: Group /flux/ of the MPO file

| Name        | Type   | Condition                | Units                  | Comment   |
|-------------|--|--------------------------|------------------------|---|
| NALBP       | I(1)   |                          |                        | Number $N_{\text{alb}}$ of physical albedo (index $a$ ) values in each energy group.  |
| NSURF       | I(1)   |                          |                        | Number $N_{\text{surf}}$ of external surfaces (index $b$ ) where discontinuity factors are defined.   |
| ALBEDOG     | R( $N_{\text{alb}}, N_{\text{grp}}$ )                          | $N_{\text{alb}} \geq 1$  | 1                      | Multigroup albedos $\beta_{a,g}$ obtained with a nodal equivalence procedure.   |
| ALBEDOGxG   | R( $N_{\text{alb}}, N_{\text{grp}}^2$ )                        | $N_{\text{alb}} \geq 1$  | 1                      | Matrix albedos $\beta_{a,g \rightarrow h}$ obtained with the equivalent reflector model (ERM).  |
| SURF        | R( $N_{\text{surf}}$ )   | $N_{\text{surf}} \geq 1$ | cm <sup>2</sup>        | Area $S_b$ of external surfaces.  |
| SURFFLUX    | R( $N_{\text{surf}}, N_{\text{mil}} \times N_{\text{grp}}$ )   | $N_{\text{surf}} \geq 1$ | $\phi$ cm <sup>2</sup> | Multigroup fluxes $\phi_{b,i,g}^s$ on external surfaces obtained with a nodal equivalence procedure in each output mixture $i$ .                  |
| SURFFLUXGxG | R( $N_{\text{surf}}, N_{\text{mil}} \times N_{\text{grp}}^2$ ) | $N_{\text{surf}} \geq 1$ | $\phi$ cm <sup>2</sup> | Matrix fluxes $\phi_{b,i,g \rightarrow h}^s$ on external surfaces obtained with the equivalent reflector model (ERM) in each output mixture $i$ . |
| TOTALFLUX   | R( $N_{\text{mil}} \times N_{\text{grp}}$ )                    |                          | $\phi$                 | Multigroup fluxes $\phi_{i,g}$ in each output mixture $i$ .   |

where  $N_{\text{mil}}$  is the number of output mixtures and  $N_{\text{grp}}$  is the number of energy groups. Discontinuity factors are obtained from equations:

$$ADF_{b,i,g} = \frac{\phi_{b,i,g}^s}{S_b \phi_{i,g}} \text{ for multigroup discontinuity factors}$$

and

$$ADF_{b,i,g \rightarrow h} = \frac{\phi_{b,i,g \rightarrow h}^s}{S_b \phi_{i,g}} \text{ for matrix discontinuity factors.}$$

### 3.20 The MC: module

This component of the lattice code is dedicated to the Monte-Carlo solution of the transport equation in multigroup approximation.

The calling specifications are:

Table 81: Structure (MC:)

```
OUTMC [ TRACK ] := MC: [ OUTMC ] TRACK { MICRO | MACRO } :: (MC_data)
```

where

|                |   |
|----------------|---|
| <i>OUTMC</i>   | <b>character*12</b> name of a MONTE-CARLO (type <code>L_MC</code> ) object open in modification or creation mode.   |
| <i>TRACK</i>   | <b>character*12</b> name of a <i>NXT: TRACKING</i> (type <code>L_TRACK</code> ) object open in read-only or modification mode. Object <i>TRACK</i> must be constructed with option MC activated (see Section 3.4.3). Opening <i>TRACK</i> in modification mode is useful to add tracking information to be plotted with module PSP: (see Section 3.31). |
| <i>MICRO</i>   | <b>character*12</b> name of a MICROLIB (type <code>L_LIBRARY</code> ) object open in read-only mode. The information on the embedded macrolib is used.  |
| <i>MACRO</i>   | <b>character*12</b> name of a MACROLIB (type <code>L_MACROLIB</code> ) object open in read-only mode.   |
| <i>MC_data</i> | input data structure containing specific data (see Section 3.20.1).   |

#### 3.20.1 Data input for module MC:

Table 82: Structure (MC\_data)

```
[ EDIT iprint ]
KCODE nsrck ikz kct
[ SEED iseed ] [ N2N ]
[ TALLY
  [ MERG { COMP | NONE |
          REGI (iregm(ii),ii=1,nregio) |
          MIX [ (imixm(ii),ii=1,nbmix) ] } ]
  [ COND [ { NONE | ( icond(ii), ii=1,ngcond) } ] ]
ENDT ]
;
```

where

|               |  |
|---------------|--|
| <i>EDIT</i>   | keyword used to set <i>iprint</i> .  |
| <i>iprint</i> | index used to control the printing in module MC:. =0 for no print; =1 for minimum printing (default value); =100 to add free-path information in object <i>TRACK</i> (must be open in modification mode in that case). |

|              |   |
|--------------|---|
| KCODE        | keyword used to define the power iteration settings.  |
| <i>nsrck</i> | number of neutrons generated per cycle  |
| <i>ikz</i>   | number of inactive cycles   |
| <i>kct</i>   | number of active cycles   |
| SEED         | keyword used to set the initial seed integer for the random number generator. By default, the seed integer is set from the processor clock.   |
| <i>iseed</i> | initial seed integer  |
| N2N          | keyword used to enable an explicit treatment of $(n, 2n)$ reactions. In this case, N2N cross sections are expected to be available in the macrolib. By default, $(n, 2n)$ reactions are taken into account implicitly by the correction on scattering cross sections.   |
| TALLY        | keyword used to define a tally (macrolib and effective multiplication factor). Using "TALLY ENDT" construct permits to obtain a virtual collision estimation of the effective multiplication factor <i>without</i> estimation of the macrolib information.  |
| NONE         | keyword to deactivate the homogenization or the condensation.   |
| MERG         | keyword to specify that the neutron flux is to be homogenized over specified regions or mixtures.   |
| REGI         | keyword to specify that the homogenization of the neutron flux will take place over the following regions. Here $nregio \leq maxreg$ with <i>maxreg</i> the maximum number of regions for which solutions were obtained.  |
| <i>iregm</i> | array of homogenized region numbers to which are associated the old regions. In the editing routines a value of <i>iregm</i> =0 allows the corresponding region to be neglected.  |
| MIX          | keyword to specify that the homogenization of the neutron flux will take place over the following mixtures. Here we must have $nbmix \leq maxmix$ where <i>maxmix</i> is the maximum number of mixtures in the macroscopic cross section library.   |
| <i>imixm</i> | array of homogenized region numbers to which are associated the material mixtures. In the editing routines a value of <i>imixm</i> =0 allows the corresponding isotopic mixtures to be neglected. For a mixture in this library which is not used in the geometry one should insert a value of 0 for the new region number associated with this mixture. By default, if MIX is set and <i>imixm</i> is not set, <i>imixm</i> ( <i>ii</i> )= <i>ii</i> is assumed. |
| COMP         | keyword to specify that the a complete homogenization is to take place.   |
| COND         | keyword to specify that a group condensation of the flux is to be performed.  |
| <i>icond</i> | array of increasing energy group limits that will be associated with each of the <i>ngcond</i> condensed groups. The final value of <i>icond</i> will automatically be set to <i>ngroup</i> while the values of <i>icond</i> > <i>ngroup</i> will be dropped from the condensation. We must have $ngcond \leq ngroup$ . By default, if COND is set and <i>icond</i> is not set, all energy groups are condensed together.   |
| ENDT         | keyword used to terminate the definition of a tally.  |

### 3.21 The T: module

A MACROLIB object can be defined directly using module MAC: (see Section 3.1) or as part of a MICROLIB object using module LIB: (see Section 3.2). It is possible to transpose a MACROLIB using the module T:. Transposition consists in

- renumbering the energy groups from thermal to fast
- transposing the transfer matrices (SCAT) so that the primary and secondary energy group indices are permuted
- storing NUSIGF information in CHI and storing CHI information in NUSIGF.

A transposed MACROLIB object permits to make adjoint flux calculations.

The general format of the data for the T: module is the following:

Table 83: Structure (T:)

```
MACLIB1 := T: { MACLIB2 | LIBRARY } ;
```

where

*MACLIB1*            **character\*12** name of a the transposed MACROLIB

*MACLIB2*            **character\*12** name of a the original MACROLIB

*LIBRARY*            **character\*12** name of a the original MICROLIB containing an embedded MACROLIB.



### 3.22 The DMAC: module

This module is used to set fixed sources that can be used in the right hand term of an adjoint fixed source eigenvalue problem. This type of equation appears in generalized perturbation theory (GPT) applications. The fixed sources set in **DMAC:** are corresponding to the gradient of a reference macrolib with respect to homogenization and condensation of the cross-section information. The gradient of a cross section  $\Sigma(\mathbf{r}) = \text{col}\{\Sigma_1(\mathbf{r}), \Sigma_2(\mathbf{r})\}$  with respect to homogenization and condensation is defined as

$$\nabla P\{\phi(\zeta); \mathbf{r}\} = P\{\phi(\mathbf{r})\} \begin{bmatrix} \frac{\Sigma_1(\mathbf{r})}{\langle \Sigma, \phi \rangle} - \frac{1}{\langle \phi \rangle} \\ \frac{\Sigma_2(\mathbf{r})}{\langle \Sigma, \phi \rangle} - \frac{1}{\langle \phi \rangle} \end{bmatrix}$$

where the homogenized and condensed cross section is an homogeneous functional of the flux defined as

$$P\{\phi(\mathbf{r})\} = \frac{\langle \Sigma, \phi \rangle}{\langle \phi \rangle} .$$

Each fixed source  $\nabla P\{\phi(\zeta); \mathbf{r}\}$  is orthogonal to the flux  $\phi(\mathbf{r})$ .

The calling specifications are:

Table 84: Structure (**DMAC:**)

*SOURCE* := **DMAC:** *FLUX* { *MICRO* | *MACRO* } *TRACK* :: (**DMAC\_data**)

where

|                  |  |
|------------------|--|
| <i>SOURCE</i>    | <b>character*12</b> name of a <b>FIXED SOURCES</b> (type <b>L_SOURCE</b> ) object open in creation mode. This object contains a set of adjoint fixed sources corresponding to different macro-regions, macro-groups and cross-section types present in the reference macrolib. |
| <i>FLUX</i>      | <b>character*12</b> name of a reference <b>FLUX</b> (type <b>L_FLUX</b> ) object open in read-only mode.   |
| <i>MICRO</i>     | <b>character*12</b> name of a reference <b>MICROLIB</b> (type <b>L_LIBRARY</b> ) object open in read-only mode. The information on the embedded macrolib is used.  |
| <i>MACRO</i>     | <b>character*12</b> name of a reference <b>MACROLIB</b> (type <b>L_MACROLIB</b> ) object open in read-only mode.   |
| <i>TRACK</i>     | <b>character*12</b> name of a reference <b>TRACKING</b> (type <b>L_TRACK</b> ) object open in read-only mode.  |
| <i>DMAC_data</i> | input data structure containing specific data (see Section <a href="#">3.22.1</a> ).   |

#### 3.22.1 Data input for module **DMAC:**

Table 85: Structure (**DMAC\_data**)

[ **EDIT** *iprint* ]  
 [ **RATE**  
   [ **MERG** { **COMP** | **NONE** |

continued on next page

Structure (DMAC\_data)

continued from last page

```

      REGI (iregm(ii),ii=1,nregio) |
      MIX [ (imixm(ii),ii=1,nbmix) ] } ]
    [ COND [ { NONE | ( icond(ii), ii=1,ngcond) } ] ]
  ENDR ]
;
```

where

|               |   |
|---------------|---|
| EDIT          | keyword used to set <i>iprint</i> .   |
| <i>iprint</i> | index used to control the printing in module DMAC: . =0 for no print; =1 for minimum printing (default value).  |
| RATE          | keyword used to define the homogenization and condensation limits.  |
| NONE          | keyword to deactivate the homogeneization or the condensation.  |
| MERG          | keyword to specify that the neutron flux is to be homogenized over specified regions or mixtures.   |
| REGI          | keyword to specify that the homogenization of the neutron flux will take place over the following regions. Here $nregio \leq maxreg$ with <i>maxreg</i> the maximum number of regions for which solutions were obtained.  |
| <i>iregm</i>  | array of homogenized region numbers to which are associated the old regions. In the editing routines a value of <i>iregm</i> =0 allows the corresponding region to be neglected.  |
| MIX           | keyword to specify that the homogenization of the neutron flux will take place over the following mixtures. Here we must have $nbmix \leq maxmix$ where <i>maxmix</i> is the maximum number of mixtures in the macroscopic cross section library.   |
| <i>imixm</i>  | array of homogenized region numbers to which are associated the material mixtures. In the editing routines a value of <i>imixm</i> =0 allows the corresponding isotopic mixtures to be neglected. For a mixture in this library which is not used in the geometry one should insert a value of 0 for the new region number associated with this mixture. By default, if MIX is set and <i>imixm</i> is not set, <i>imixm</i> ( <i>ii</i> )= <i>ii</i> is assumed. |
| COMP          | keyword to specify that the a complete homogenization is to take place.   |
| COND          | keyword to specify that a group condensation of the flux is to be performed.  |
| <i>icond</i>  | array of increasing energy group limits that will be associated with each of the <i>ngcond</i> condensed groups. The final value of <i>icond</i> will automatically be set to <i>ngroup</i> while the values of <i>icond</i> > <i>ngroup</i> will be dropped from the condensation. We must have $ngcond \leq ngroup$ . By default, if COND is set and <i>icond</i> is not set, all energy groups are condensed together.   |
| ENDR          | keyword used to terminate the definition of the homogenization and condensation.  |

### 3.23 The SENS: module

This module is used to perform an explicit sensitivity analysis of keff to nuclear data represented by the cross sections.<sup>[116]</sup> The calculations are performed using adjoint-based first-order-linear perturbation theory and require the adjoint flux (see Section 3.6). The sensitivity coefficients are stored in a *SDF* text file that is compatible with the JAVAPENO module of SCALE<sup>[117]</sup> (this compatibility is achieved via a slight modification of the *rdragon* execution script). An example of modification is presented in the file *sens.save* from the *non regression testcase sens.x2m*.

The calling specifications are:

Table 86: Structure (SENS:)

```
SENS.sdf := SENS: FLUNAM ADJ_FLUNAM TRKNAM MACRO :: (SENS_data)
```

where

|                   |   |
|-------------------|---|
| <i>SENS.sdf</i>   | character*12 name of a SDF file object that is created by SENS:.                            |
| <i>FLUNAM</i>     | character*12 name of the required FLUX (type L_FLUX) object open in read-only mode.         |
| <i>ADJ_FLUNAM</i> | character*12 name of the required ADJOINT FLUX (type L_FLUX) object open in read-only mode. |
| <i>TRKNAM</i>     | character*12 name of the required TRACKING (type L_TRACK) object open in read-only mode.    |
| <i>MACRO</i>      | character*12 name of the required MACROLIB (type L_MACROLIB) object open in read-only mode. |
| <i>SENS_data</i>  | input data structure containing specific data (see Section 3.23.1).                         |

#### 3.23.1 Data input for module SENS:

Table 87: Structure (SENS\_data)

```
[ EDIT iprint ]
[ ANIS nanis ]
;
```

where

|               |   |
|---------------|---|
| EDIT          | keyword used to set <i>iprint</i> .   |
| <i>iprint</i> | index used to control the printing in module SENS:. =0 for no print; =1 for minimum printing (default value).   |
| ANIS          | keyword used to specify the level <i>naniso</i> of anisotropy permitted in the calculation.   |
| <i>nanis</i>  | number of Legendre orders for the representation of the scattering cross sections and the anisotropy of the flux. The default value is <i>nanis</i> =1 corresponding to the use |

of isotropic scattering cross sections and integrated flux. The number of Legendre orders used for the sensitivity calculations is the lowest between *nanis* and the level of anisotropy available in the *MACRO* data.

### 3.24 The DUO: module

This module is used to perform a perturbative analysis of two systems in fundamental mode conditions using the Clío formula and to determine the origins of Keff discrepancies.

The calling specifications are:

Table 88: Structure (DUO:)

```
DUO: MICLIB1 MICLIB2 :: (DUO_data)
```

where

|                 |   |
|-----------------|---|
| <i>MICLIB1</i>  | <code>character*12</code> name of the first MICROLIB (type <code>L_LIBRARY</code> ) object open in read-only mode.  |
| <i>MICLIB2</i>  | <code>character*12</code> name of the second MICROLIB (type <code>L_LIBRARY</code> ) object open in read-only mode. |
| <i>DUO_data</i> | input data structure containing specific data (see Section 3.24.1).   |

#### 3.24.1 Data input for module DUO:

Note that the input order must be respected.

Table 89: Structure (DUO\_data)

```
[ EDIT iprint ]
[ ENERGY ] [ ISOTOPE ] [ MIXTURE ]
[ REAC
  [[ reac [ PICK >> deltaRho << ] ]]
  ENDREAC ]
;
```

where

|                      |  |
|----------------------|--|
| <code>EDIT</code>    | keyword used to set <i>iprint</i> .  |
| <i>iprint</i>        | index used to control the printing in module DUO:. =0 for no print; =1 for minimum printing (default value). |
| <code>ENERGY</code>  | keyword used to perform a perturbation analysis as a function of the energy group indices.                   |
| <code>ISOTOPE</code> | keyword used to perform a perturbation analysis as a function of the isotopes present in the geometry.       |
| <code>MIXTURE</code> | keyword used to perform a perturbation analysis as a function of the mixtures indices.                       |
| <code>REAC</code>    | keyword used to perform a perturbation analysis for specific nuclear reactions.                              |

*reac*            **character\*8** name of a nuclear reaction  $\sigma_x$ . The reactivity effect is computed using the formula

$$\delta\lambda_x = \frac{(\phi_1^*)^\top \delta \mathbb{S}_x \phi_2}{(\phi_1^*)^\top \mathbb{P}_2 \phi_2}. \quad (3.42)$$

where  $\mathbb{S}_x$  is a matrix containing the the contributions of the reaction  $\sigma_x$ . The other symbols are defined in Sect. 3.24.2. Examples of reaction names are:

**NTOTO:** total cross section

**NG:** radiative capture cross section

**N2N:** (n,2n) cross section

**NFTOT:** fission cross section

**NELAS:** elastic scattering cross section

**SCAT00:** scattering matrix

**NUSIGF:** dyadic product of the fission spectrum times  $\nu$  fission cross section

**LEAK:** neutron leakage

The balance relation for the global reactivity effect is

$$\delta\lambda = \delta\lambda_{\text{NTOTO}} - \delta\lambda_{\text{SCAT00}} - \frac{\delta\lambda_{\text{NUSIGF}}}{K_{\text{eff}}} + \delta\lambda_{\text{LEAK}} \quad (3.43)$$

where  $K_{\text{eff}}$  is the effective multiplication factor.

**PICK**            keyword used to recover the delta-rho discrepancy for reaction *reac* in a CLE-2000 variable.

*deltaRho*        **character\*12** CLE-2000 variable name in which the extracted delta-rho discrepancy will be placed.

**ENDREAC**        keyword used to indicate that no more nuclear reactions will be analysed.

### 3.24.2 Theory

The module **DUO**: is an implementation of the CLIO perturbative analysis method, as introduced in Ref. 118. This method is useful for comparing two similar systems in fundamental mode conditions. It is based on fundamental mode balance equations that must be satisfied by the direct and adjoint solutions of each of the two systems. The balance equation of the first system is written

$$\mathbb{L}_1 \phi_1 - \lambda_1 \mathbb{P}_1 \phi_1 = \mathbf{0} \quad \text{and} \quad \mathbb{L}_1^\top \phi_1^* - \lambda_1 \mathbb{P}_1^\top \phi_1^* = \mathbf{0} \quad (3.44)$$

where

$\mathbb{L}_1$  = absorption (total plus leakage minus scattering) reaction rate matrix

$\mathbb{P}_1$  = production (nu times fission) reaction rate matrix

$\lambda_1$  = one over the effective multiplication factor

$\phi_1$  = direct multigroup flux in each mixture of the geometry

$\phi_1^*$  = adjoint multigroup flux in each mixture of the geometry.

Similarly, the balance equation of the second system is written

$$\mathbb{L}_2 \phi_2 - \lambda_2 \mathbb{P}_2 \phi_2 = \mathbf{0}. \quad (3.45)$$

Next, we write

$$\mathbb{L}_2 = \mathbb{L}_1 + \delta \mathbb{L} \quad \mathbb{P}_2 = \mathbb{P}_1 + \delta \mathbb{P}, \quad \phi_2 = \phi_1 + \delta \phi \quad \text{and} \quad \lambda_2 = \lambda_1 + \delta \lambda. \quad (3.46)$$

Substituting Eq. (3.46) into Eq. (3.45), we write

$$\mathbb{L}_1 \phi_1 + \mathbb{L}_1 \delta \phi + \delta \mathbb{L} \phi_2 - [\lambda_1 \mathbb{P}_1 \phi_1 + \lambda_1 \mathbb{P}_1 \delta \phi + (\lambda_2 \mathbb{P}_2 - \lambda_1 \mathbb{P}_1) \phi_2] = \mathbf{0}. \quad (3.47)$$

Following the guideline from Ref. 118, we subtract Eq. (3.44) from Eq. (3.47) to obtain

$$(\mathbb{L}_1 - \lambda_1 \mathbb{P}_1) \delta \phi = (-\delta \mathbb{L} + \lambda_2 \mathbb{P}_2 - \lambda_1 \mathbb{P}_1) \phi_2 \quad (3.48)$$

Next, we left-multiply this matrix system by a row vector equal to  $(\phi_1^*)^\top$ , in order to make the LHS vanishing. This operation is written

$$(\phi_1^*)^\top (\mathbb{L}_1 - \lambda_1 \mathbb{P}_1) \delta \phi = (\phi_1^*)^\top (-\delta \mathbb{L} + \lambda_2 \mathbb{P}_2 - \lambda_1 \mathbb{P}_1) \phi_2 = 0 \quad (3.49)$$

because

$$(\phi_1^*)^\top (\mathbb{L}_1 - \lambda_1 \mathbb{P}_1) = \mathbf{0}^\top \quad (3.50)$$

in term of Eq. (3.44).

Using the relation  $\lambda_2 \mathbb{P}_2 - \lambda_1 \mathbb{P}_1 = \delta \lambda \mathbb{P}_2 + \lambda_1 \delta \mathbb{P}$ , Eq. (3.49) can be rewritten as

$$(\phi_1^*)^\top (-\delta \mathbb{L} + \delta \lambda \mathbb{P}_2 + \lambda_1 \delta \mathbb{P}) \phi_2 = 0 \quad (3.51)$$

so that

$$\delta \lambda = \frac{(\phi_1^*)^\top (\delta \mathbb{L} - \lambda_1 \delta \mathbb{P}) \phi_2}{(\phi_1^*)^\top \mathbb{P}_2 \phi_2}. \quad (3.52)$$

Equation 3.52 is *not* a first order perturbation approximation of  $\delta \lambda$ ; it is an *exact* expression of it. Its numerator is used to obtain every component of  $\delta \lambda$  in term of energy group, isotope, mixture and/or nuclear reaction.

### 3.25 The S2M: module

This module is used to extract macroscopic cross-section data from a Matlab-formatted ASCII file generated by the SERPENT Monte Carlo code (see Ref. 121) and to convert it to the MACROLIB format.

The calling specifications are:

Table 90: Structure (S2M:)

```
MACRO := S2M: matlab.m :: (S2M_data)
```

where

|                 |  |
|-----------------|--|
| <i>MACRO</i>    | <b>character*12</b> name of the required MACROLIB (type <b>L_MACROLIB</b> ) object that is created by <b>S2M:.</b> |
| <i>matlab.m</i> | <b>character*12</b> name of a ASCII file, open in read-only mode, containing Matlab-formatted SERPENT information. |
| <i>S2M_data</i> | input data structure containing specific data (see Section 3.25.1).  |

#### 3.25.1 Data input for module S2M:

Table 91: Structure (S2M\_data)

```
[ EDIT iprint ]
[ IDX idx ]
[ B1 ]
;
```

where

|               |  |
|---------------|--|
| <b>EDIT</b>   | keyword used to set <i>iprint</i> .  |
| <i>iprint</i> | index used to control the printing in module <b>S2M:.</b> =0 for no print; =1 for minimum printing (default value).                            |
| <b>IDX</b>    | keyword used to specify the occurrence index of a flux calculation in the SERPENT output file. This index generally refers to the burnup step. |
| <i>idx</i>    | occurrence index.  |
| <b>B1</b>     | keyword used to specify that diffusion coefficients and other fundamental-mode information are to be recovered from the SERPENT output file.   |



### 3.26 The FMT: module

The utility module **FMT:** is used to format various data structure to suit the specific user needs. Here three formatting options are available.

1. The **SUS3D** option where three files are created that respectively contain the integration weights and directions (ASCII), the directional flux (binary or ASCII) and the directional adjoints (binary or ASCII) in a CP or  $S_N$  format.<sup>[85,86]</sup> The input specifications for this option are

Table 92: Structure (**FMT:**) for SUS3D option

```
WGTANGL DFLUX DADJOINTS := FMT: FLUX VOLTRK ::
  [ EDIT iprint ]
  SUS3D [ { SN | CP } ]
```

2. The **DIRFLX** option where a single file is created that contain the directional flux, adjoints and generalized adjoints. The input specifications for this option are

Table 93: Structure (**FMT:**) for DIRFLX option

```
DAF := FMT: FLUX VOLTRK ::
  [ EDIT iprint ]
  DIRFLX
```

3. The **BURNUP** option where a Matlab-m or Python file is created that contain the burnup time, the variation of  $k_{\text{eff}}$  with time and the time dependent concentration of the different isotopes present in the geometry. The input specifications for this option are

Table 94: Structure (**FMT:**) for BURNUP option

```
MFILE := FMT: EDITION BURNUP ::
  [ EDIT iprint ]
  BURNUP [ { MATLAB | PYTHON } ]
  [ ISOP [ (NAMISO(i), i = 1, I) ] ]
```

|                  |   |
|------------------|---|
| <b>WGTANGL</b>   | <b>character*12</b> name of the ASCII file that will contain the angular weights and directions.                              |
| <b>DFLUX</b>     | <b>character*12</b> name of the ASCII or BINARY file that will contain the directional flux in a SUS3D compatible format.     |
| <b>DADJOINTS</b> | <b>character*12</b> name of the ASCII or BINARY file that will contain the directional adjoints in a SUS3D compatible format. |

|                |  |
|----------------|--|
| <i>DAF</i>     | character*12 name of the ASCII file that will contain the spherical harmonic moments of the fluxes, adjoints and generalized adjoints in a DIRFLX compatible format.                     |
| <i>FLUX</i>    | character*12 name of the FLUXUNK data structure to process.  |
| <i>VOLTRK</i>  | character*12 name of the TRACKING data structure to process.   |
| <i>MFILE</i>   | character*12 name of the ASCII Matlab M-file that will contain the burnup time, the time dependent $k_{\text{eff}}$ and concentration of the different isotopes present in the geometry. |
| <i>EDITION</i> | character*12 name of the EDITION data structure to process.  |
| <i>BURNUP</i>  | character*12 name of the BURNUP data structure to process.   |
| <i>EDIT</i>    | keyword used to modify the print level <i>iprint</i> .   |
| <i>iprint</i>  | index used to control the printing in this module.   |
| <i>SUS3D</i>   | keyword to activate the SUS3D processing option.   |
| <i>SN</i>      | keyword to generate $S_N$ compatible fluxes and adjoints (cell edge values). It is the default value.  |
| <i>CP</i>      | keyword to generate CP compatible fluxes and adjoints (cell averaged values).  |
| <i>DIRFLX</i>  | keyword to activate the DIRFLX processing option.  |
| <i>BURNUP</i>  | keyword to activate the BURNUP processing option.  |
| <i>MATLAB</i>  | keyword to create a Matlab-m file. This is the default option.   |
| <i>PYTHON</i>  | keyword to create a Python-py file.  |
| <i>ISOP</i>    | keyword to activate the istope processing. If <i>ISOP</i> is absent, only the time and time dependent $k_{\text{eff}}$ are saved.  |
| <i>NAMISO</i>  | name of istopes to precess. If no isitope name is specified, all the isotopes are processed.   |

### 3.27 The FMAC: module

This module is used to extract macroscopic cross-section data from a FMAC-M ASCII file. Transition source information from companion particles are recovered from the FMAC-M file and written in the output MACROLIB.

The calling specifications are:

Table 95: Structure (**FMAC:**)

```
MACRO := FMAC: fmac.txt :: (FMAC_data)
```

where

|                  |  |
|------------------|--|
| <i>MACRO</i>     | <b>character*12</b> name of the output MACROLIB (type <b>L_MACROLIB</b> ) object that is created by <b>FMAC:</b> . |
| <i>fmac.txt</i>  | <b>character*12</b> name of a ASCII file, open in read-only mode, containing FMAC-M information.                   |
| <i>FMAC_data</i> | input data structure containing specific data (see Section <a href="#">3.27.1</a> ).                               |

#### 3.27.1 Data input for module **FMAC:**

Table 96: Structure (**FMAC\_data**)

```
[ EDIT iprint ]  
PARTICLE htype  
;
```

where

|                 |  |
|-----------------|--|
| <b>EDIT</b>     | keyword used to set <i>iprint</i> .  |
| <i>iprint</i>   | index used to control the printing in module <b>FMAC:</b> . =0 for no print; =1 for minimum printing (default value).  |
| <b>PARTICLE</b> | keyword used to specify the type of particle corresponding to the MACROLIB (secondary state of the transition).  |
| <i>htype</i>    | <b>character*1</b> name of the particle. Usual names are <b>N</b> : neutrons, <b>G</b> : photons, <b>B</b> : electrons, <b>C</b> : positrons and <b>P</b> : protons. |

### 3.28 The PSOUR: module

This module is used to set transition sources in a multi-particle coupled transport problem or boundary sources in Cartesian geometry. The `PSOUR:` module is currently limited to a SN discretization.

The calling specifications are:

Table 97: Structure (**PSOUR:**)

```
SOURCE := PSOUR: [ SOURCE ] { MICRO | MACRO } TRACK [ GEONAM ] [[ FLUX ]]
[[ SOURCE2 ]] :: (PSOUR_data)
```

where

|                   |  |
|-------------------|--|
| <i>SOURCE</i>     | <code>character*12</code> name of a FIXED SOURCE (type <code>L_SOURCE</code> ) object open in creation or modification mode. This object contains a unique direct or adjoint fixed source taking into account scattering transitions from one or many companion particles and/or boundary sources.     |
| <i>MICRO</i>      | <code>character*12</code> name of a reference MICROLIB (type <code>L_LIBRARY</code> ) object open in read-only mode. The information on the embedded macrolib is used.   |
| <i>MACRO</i>      | <code>character*12</code> name of a reference MACROLIB (type <code>L_MACROLIB</code> ) object open in read-only mode.  |
| <i>TRACK</i>      | <code>character*12</code> name of a reference TRACKING (type <code>L_TRACK</code> ) object, corresponding to <code>L_SOURCE</code> object, open in read-only mode.   |
| <i>GEONAM</i>     | <code>character*12</code> name of a reference GEOMETRY (type <code>L_GEOM</code> ) object, corresponding to <code>L_SOURCE</code> object, open in read-only mode. This object is required if and only if one of keywords <code>ISO</code> or <code>MONO</code> is set.                                 |
| <i>FLUX</i>       | <code>character*12</code> name of a FLUX (type <code>L_FLUX</code> ) object corresponding to a companion particle open in read-only mode and used to compute transition sources. The number of FLUX objects on the RHS is equal to the number of companion particles contributing to the fixed source. |
| <i>SOURCE2</i>    | <code>character*12</code> name of a FIXED SOURCE (type <code>L_SOURCE</code> ) object open in read-only mode. The fixed source in <i>SOURCE2</i> is added to <i>SOURCE</i> .   |
| <i>PSOUR_data</i> | input data structure containing specific data (see Section 3.28.1).  |

#### 3.28.1 Data input for module PSOUR:

Table 98: Structure (**PSOUR\_data**)

```
[ EDIT iprint ]
{
  [[ PARTICLE htype ]]
  |
```

continued on next page

Structure (**PSOUR\_data**)

continued from last page

```

ISO nsource
INTG {ig(i) int(i), i | int(i), i=1,ng}
XLIM (xmin(i) xmax(i), i=1,nsource)
[YLIM (ymin(i) ymax(i), i=1,nsource)]
[ZLIM (zmin(i) zmax(i), i=1,nsource)]
|
MONO nsource
INTG {ig(i) int(i), i | int(i), i=1,ng}
{ X- | X+ | Y- | Y+ | Z- | Z+ }
DIR {mu eta xi | polar azimuthal}
[XLIM (xmin(i) xmax(i), i=1,nsource)]
[YLIM (ymin(i) ymax(i), i=1,nsource)]
[ZLIM (zmin(i) zmax(i), i=1,nsource)]
}
;
```

where

|                  |  |
|------------------|--|
| EDIT             | keyword used to set <i>iprint</i> .  |
| <i>iprint</i>    | index used to control the printing in module PSOUR:. =0 for no print; =1 for minimum printing (default value).   |
| PARTICLE         | keyword used to specify the transition type recovered from the MACROLIB (primary state of the transition). This keyword is repeated for each type of companion particles, in the same order as the <i>FLUX</i> objects on the RHS. |
| <i>htype</i>     | character*1 name of the companion particle. Usual names are N: neutrons, G: photons, B: electrons, C: positrons and P: protons.  |
| ISO              | keyword used to define an isotropic volumetric source.   |
| MONO             | keyword used to define a monodirectional boundary source.  |
| <i>nsource</i>   | number of sources of the choosen type.   |
| INTG             | keyword to specify the energy spectrum of the source.  |
| <i>ig</i>        | index of the energy group in which the source is defined.  |
| <i>int</i>       | source intensity. With ISO, it is defined as the number of particules per volume unit per time unit. With MONO, it is defined as the number of particles per surface unit per time unit.   |
| XLIM             | keywords to specify the <i>nsource</i> source volume (with ISO) or surface dimension (with MONO) along the X-axis.   |
| YLIM             | keywords to specify the <i>nsource</i> source volume (with ISO) or surface dimension (with MONO) along the Y-axis.   |
| ZLIM             | keywords to specify the <i>nsource</i> source volume (with ISO) or surface dimension (with MONO) along the Z-axis.   |
| <i>xmin/xmax</i> | boundaries for each of the <i>nsource</i> volume or surface sources along respectively the X-axis.   |

|                       |   |
|-----------------------|---|
| <i>ymin/ymax</i>      | boundaries for each of the <i>nsource</i> volume or surface sources along respectively the <i>Y</i> -axis.                      |
| <i>zmin/zmax</i>      | boundaries for each of the <i>nsource</i> volume or surface sources along respectively the <i>Z</i> -axis.                      |
| <i>X-/X+</i>          | keyword to specify that the MONO-type source is located on the negative or positive <i>X</i> surface of the Cartesian geometry. |
| <i>Y-/Y+</i>          | keyword to specify that the MONO-type source is located on the negative or positive <i>Y</i> surface of the Cartesian geometry. |
| <i>Z-/Z+</i>          | keyword to specify that the MONO-type source is located on the negative or positive <i>Z</i> surface of the Cartesian geometry. |
| <i>DIR</i>            | keyword to specify the orientation of the MONO-type source.   |
| <i>mu/eta/xi</i>      | direction cosines along respectively the <i>X</i> -, <i>Y</i> - and <i>Z</i> -axis.   |
| <i>polar/azimutal</i> | polar and azimuthal angle in degree, with the <i>X</i> -axis as the principal axis.   |

### 3.29 The HEAT: module

This module is used to compute the energy and charge deposition values from many particles. The calling specifications are:

Table 99: Structure (**HEAT:**)

```
DEPOS := HEAT: [ DEPOS ] [[ MACRO ]] :: (HEAT_data)
```

where

|                  |   |
|------------------|---|
| <i>DEPOS</i>     | <b>character*12</b> name of a DEPOSITION (type L_DEPOSITION) object containing mixture-ordered energy and charge deposition values, summed over many extended macrolibs. This object can be created by module <b>HEAT:</b> or used in modification mode to accumulate deposition values gathered from successive solutions of the Boltzmann and/or Boltzmann Fokker-Planck transport equations. |
| <i>MACRO</i>     | <b>character*12</b> name of an extended MACROLIB (type L_MACROLIB) object containing FLUX-INTG and H-FACTOR values. C-FACTOR values are also recovered if they are available. There are as many macrolibs on the RHS as particles contributing to the energy and charge deposition.   |
| <i>HEAT_data</i> | input data structure containing specific data (see Section 3.29.1).   |

#### 3.29.1 Data input for module HEAT:

Table 100: Structure (**HEAT\_data**)

```
[ EDIT iprint ]
[ { POWR power | SOUR snumb | NORM rho(i), i=1,nbmix } ]
[ { BC | NBC } ]
[ { PICKE >> esum << | PICKC >> csum << } ]
;
```

where

|               |   |
|---------------|---|
| <b>EDIT</b>   | keyword used to set <i>iprint</i> .   |
| <i>iprint</i> | index used to control the printing in module <b>HEAT:</b> . =0 for no print; =1 for minimum printing (default value).                             |
| <b>POWR</b>   | keyword used to set <i>power</i> .  |
| <i>power</i>  | value of the power in MW used to normalize the flux. By default, the flux is not normalized.  |
| <b>SOUR</b>   | keyword used to set <i>snumb</i> . Fixed source information (record <b>FIXE</b> ) must be available in the first extended macrolib <i>MACRO</i> . |
| <i>snumb</i>  | number of source particles used to normalize the flux. By default, the flux is not normalized.  |

|             |   |
|-------------|---|
| NORM        | keyword used to obtain the energy deposition per voxels by normalizing the flux by the total number of source particles and the voxel material density. The output units are MeV/g×cm <sup>N</sup> per particles, where <i>N</i> is the geometry dimension. |
| <i>rho</i>  | densities in g/cm <sup>3</sup> of the <i>nbmix</i> material defined in calculations.  |
| BC          | keyword used to take into account the contribution of the particules falling below the cutoff energy to the charge and energy deposition calculations using method from Morel <sup>[123]</sup> (by default).  |
| NBC         | keyword used to disable the contribution of the particules falling below the cutoff energy to the charge and energy deposition calculations.  |
| PICKE       | keyword used to recover the total energy deposition value (MeV/cm <sup>3</sup> /s) in a CLE-2000 variable.  |
| <i>esum</i> | <b>character*12</b> CLE-2000 variable name in which the extracted total energy deposition value will be placed.   |
| PICKC       | keyword used to recover the total charge deposition value (electrons/cm <sup>3</sup> /s) in a CLE-2000 variable.  |
| <i>csum</i> | <b>character*12</b> CLE-2000 variable name in which the total charge deposition value will be placed.   |



### 3.30 The BREF: module

This module compute a MACROLIB for a 1D *equivalent reflector* based on various models. One or many fine-group and fine-mesh reference calculations (using the  $S_n$  method) are first performed so as to produce coarse-group and coarse-mesh Macrolibs stored within output EDITION objects (*EDIT-SN*), compatible with the selected reflector model. Module **BREF:** recovers the  $S_n$  GEOMETRY, depicted in Fig. 23, from object *GEOM-SN*. The  $S_n$  GEOMETRY must have a reflective (REFL or ALBE 1.0) boundary condition on its left (X-) boundary. Module **BREF:** recovers the following information from each *EDIT-SN* object:

- Coarse group surfacic fluxes between the nodes using averaged flux values recovered into *gap* volumes, corresponding to tiny meshes in the reflector zones.
- Coarse group net currents between the nodes obtained from a balance relation, assuming reflection on the left boundary.
- Averaged macroscopic cross sections and diffusion coefficients within the *no-gap* homogenized nodes.

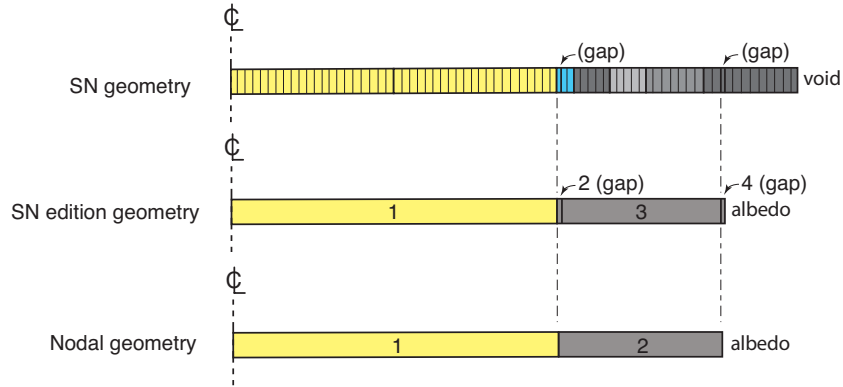

Figure 23: Definition of geometries used by the **BREF:** module

At output, a MACROLIB object is produced with equivalent macroscopic cross sections, diffusion coefficients, discontinuity factors and albedos. A verification calculation performed over the **BREF:** geometry is depicted in Fig. 24,

Nodal expansion base functions are used to represent the flux with the DF-NEM and ERM-NEM methods. By default, polynomials defined over  $(-0.5, 0.5)$  are used as base functions:<sup>[87]</sup>

$$\begin{aligned}
 P_0(u) &= 1 \\
 P_1(u) &= u \\
 P_2(u) &= 3u^2 - \frac{1}{4} \\
 P_3(u) &= \left(u^2 - \frac{1}{4}\right)u \\
 P_4(u) &= \left(u^2 - \frac{1}{4}\right)\left(u^2 - \frac{1}{20}\right)
 \end{aligned} \tag{3.53}$$

There is the option of using hyperbolic functions in some energy groups:

$$\begin{aligned}
 P_3(u) &= \sinh(\zeta_g u) \\
 P_4(u) &= \cosh(\zeta_g u) - \frac{2}{\zeta} \sinh(\zeta_g/2)
 \end{aligned} \tag{3.54}$$

where

$$\zeta_g = \Delta x \sqrt{\frac{\Sigma_{r,g}}{D_g}} \tag{3.55}$$

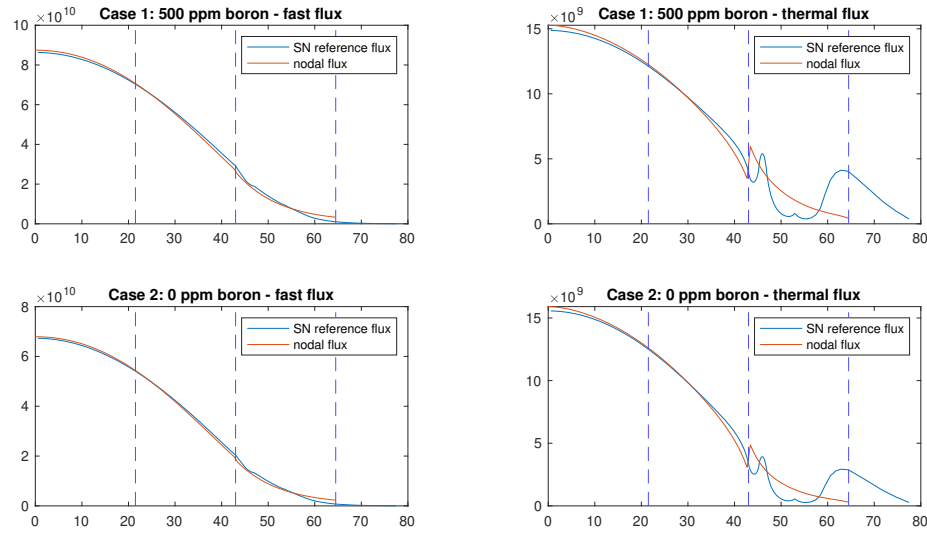

Figure 24: Equivalent ERM-NEM reflector for the BEAVRS benchmark

where  $\Delta x$ ,  $\Sigma_{r,g}$  and  $D_g$  are the node width (cm), the macroscopic removal cross section ( $\text{cm}^{-1}$ ) and the diffusion coefficient (cm) in group  $g$ , respectively.

Other equivalence techniques are known as DF-ANM and ERM-ANM. These techniques are similar to DF-NEM and ERM-NEM where the nodal expansion method (NEM) is replaced by an analytic solution of the  $G$ -group diffusion equation.

The calling specifications are:

Table 101: Structure (BREF:)

```
GEOM MACRO := BREF: GEOM_SN [[ EDIT_SN ]] :: (BREF_data)
```

where

|                  |  |
|------------------|--|
| <i>GEOM</i>      | <b>character*12</b> name of the nodal GEOMETRY (type L_GEOM) object open creation mode. This geometry can be used for performing a verification calculation over the 1D nodal geometry.  |
| <i>MACRO</i>     | <b>character*12</b> name of the nodal MACROLIB (type L_MACROLIB) object open in creation mode.   |
| <i>GEOM_SN</i>   | <b>character*12</b> name of the $S_n$ GEOMETRY (type L_GEOM) object open read-only mode.   |
| <i>EDIT_SN</i>   | <b>character*12</b> name of one or many $S_n$ EDITION (type L_EDIT) object, containing coarse-group and coarse-mesh MACROLIB for the edition MACRO-GEOMETRY with gaps corresponding to one or many reference $S_n$ calculations. |
| <i>BREF_data</i> | input data structure containing specific data (see Section 3.30.1).  |

## 3.30.1 Data input for module BREF:

Table 102: Structure (**BREF\_data**)

```
[ EDIT iprint ]
[ HYPE igmax ]
MIX [[ imix ]] GAP [[ igap ]]
MODE hmod
[ { SPH | NOSP } ] [ { ALBE | NOAL } ]
[ NGET [ (adf(g), g=1,Ng) ] ]
;
```

where

|               |  |
|---------------|--|
| EDIT          | keyword used to set <i>iprint</i> .  |
| <i>iprint</i> | index used to control the printing in module BREF: . =0 for no print; =1 for minimum printing (default value).   |
| HYPE          | keyword used to specify the type of nodal expansion base functions with the DF-NEM and ERM-NEM methods. By default, polynomial base functions are used in all energy groups.   |
| <i>igmax</i>  | hyperbolic base functions are used for coarse energy groups with indices $\geq$ <i>igmax</i> .   |
| MIX           | keyword used to set the nodal mixture indices <i>imix</i> .  |
| <i>imix</i>   | index of a mixture index within object <i>EDIT_SN</i> corresponding to a node. In Fig. 23, this data is set as MIX 1 3 for DF-NEM, DF-ANM, ERM-NEM and ERM-ANM geometries and to MIX 0 3 for LEFEBVRE-LEB and KOEBKE geometries.   |
| GAP           | keyword used to set the gap mixture indices <i>igap</i> where the surfacic fluxes are recovered.   |
| <i>igap</i>   | index of a mixture index within object <i>EDIT_SN</i> corresponding to a gap. In Fig. 23, this data is set as GAP 2 4 for DF-NEM, DF-ANM, ERM-NEM and ERM-ANM geometries and to GAP 2 0 for LEFEBVRE-LEB and KOEBKE geometries.  |
| MODE          | keyword used to select a specific reflector equivalence model.   |
| <i>hmod</i>   | character*12 name of the reflector equivalence model used. The following options are available: <ul style="list-style-type: none"> <li>LEFEBVRE-LEB: Lefebvre-Lebigot equivalence model. Two <i>EDIT_SN</i> objects are expected at RHS.<sup>[88,90]</sup></li> <li>KOEBKE: Koebke equivalence model. Two <i>EDIT_SN</i> objects are expected at RHS.<sup>[89,90]</sup></li> <li>DF-NEM: Pure discontinuity-factor model based on the nodal expansion method (NEM). Only one <i>EDIT_SN</i> object is expected at RHS.</li> <li>DF-ANM: Pure discontinuity-factor model based on the analytic nodal method (ANM). Only one <i>EDIT_SN</i> object is expected at RHS.</li> <li>ERM-NEM: <i>Equivalent reflector model</i> based on <i>matrix discontinuity factors</i> and nodal expansion method (NEM). Two or more <i>EDIT_SN</i> objects are expected at RHS.</li> </ul> |

**ERM-ANM:** *Equivalent reflector model* based on *matrix discontinuity factors* and analytic nodal method (ANM). Two or more *EDIT\_SN* objects are expected at RHS.

|            |   |
|------------|---|
| SPH        | keyword used to include discontinuity factors within cross sections and diffusion coefficients. This option is not available with models ERM-NEM and ERM-ANM.   |
| NOSP       | keyword used to store discontinuity factors in MACROLIB <i>MACRO</i> (default option).  |
| ALBE       | keyword used to compute an equivalent albedo in each coarse energy group with DF-NEM, DF-ANM, ERM-NEM and ERM-ANM models (default option).  |
| NOAL       | keyword used to deactivate equivalent albedo calculation.   |
| NGET       | keyword used to force the value of the fuel assembly discontinuity factor at the fuel-reflector interface, as used by the NGET normalization. By default, this value is not modified by NGET normalization.             |
| <i>adf</i> | value of the assembly discontinuity factor (ADF) on the fuel-reflector interface in group $g \leq N_g$ . If keyword NGET is set and <i>adf</i> values are not given, the ADF values are recovered from <i>EDIT_SN</i> . |

### 3.31 The PSP: module

The PSP: module is used to generate a graphical file in a PostScript ASCII format for a DRAGON 2-D geometry which can be analyzed using the EXCELT: or NXT: tracking module (see Sections 3.4.2 and 3.4.3). The module PSP: is based on the PSPLOT Fortran library from Nova Southeastern University.<sup>[91]</sup> Since only a few PSPLOT routines were required and because additional PostScript routine not present in the original package were needed, the routines have been completely readapted to DRAGON. These routines are no longer machine dependent. The PostScript files generated by DRAGON can be viewed by any PostScript viewer, such as Ghostview<sup>[92]</sup> or sent to a printer compatible with this language. In DRAGON the PSP: module is activated using the following list of commands:

Table 103: Structure (PSP:)

```
PSGEO := PSP: PSGEO { GEONAM | TRKNAM } [ FLUNAM ] :: (descpsp)
```

where

|                    |   |
|--------------------|---|
| <i>PSGEO</i>       | <b>character*12</b> name of the file that will contain the graphical description in a POSTSCRIPT format. This file must have a sequential ASCII format. |
| <i>GEONAM</i>      | <b>character*12</b> name of a read-only GEOMETRY (see Section Section 3.3).   |
| <i>TRKNAM</i>      | <b>character*12</b> name of an NXT or EXCELL type read-only TRACKING (see Sections 3.4.2 and 3.4.3).  |
| <i>FLUNAM</i>      | <b>character*12</b> name of an optional read-only FLUXUNK (see Section 3.6). It is required only if a flux mapping plot is requested.                   |
| ( <b>descpsp</b> ) | structure containing the input data to this module (see Section 3.31.1).  |

#### 3.31.1 Data input for module PSP:

Table 104: Structure (descpsp)

```
[ EDIT iprint ]
[ FILL { NONE | GRAY | RGB | CMYK | HSB } [ NOCONTOUR ] ]
[ TYPE { REGION | MIXTURE | FLUX | MGFLUX } ]
```

where

|               |   |
|---------------|---|
| EDIT          | keyword used to modify the print level <i>iprint</i> .  |
| <i>iprint</i> | index used to control the printing in this module. It must be set to 0 if no printing on the output file is required. |
| FILL          | keyword to specify the drawing options.   |
| NONE          | keyword to specify that only region contour are to be drawn.  |

|           |  |
|-----------|--|
| GRAY      | keyword to specify that the regions will be filled with various levels of gray.  |
| RGB       | keyword to specify that the regions will be filled with various colors taken using the RGB color scheme.                             |
| CMYK      | keyword to specify that the regions will be filled with various colors taken using the CMYK color scheme.                            |
| HSB       | keyword to specify that the regions will be filled with various colors taken using the HSB color scheme. This is the default option. |
| NOCONTOUR | keyword to specify that the contour lines delimiting each region will not be drawn.  |
| TYPE      | keyword to specify the type of graphics generated.   |
| REGION    | keyword to specify that different colors or gray levels will be associated with each region. This is the default option.             |
| MIXTURE   | keyword to specify that different colors or gray levels will be associated with each mixture.  |
| FLUX      | keyword to specify that the group integrated flux is to be drawn.  |
| MGFLUX    | keyword to specify that the group flux is to be drawn.   |

### 3.32 The CLM: module

The CLM: module is called to mix and redistribute several liquid mixtures containing identical isotopes contents (different isotopic densities). The module can also change the density of any isotope in the mixture. The calling specifications are:

Table 105: Structure (CLM:)

```
MICLIB := CLM: MICLIB :: (descclm)
```

where

*MICLIB*            **character\*12** name of the MICROLIB that will contain the microscopic and macroscopic cross sections updated by the module.

**(descclm)**        structure describing the clm options.

#### 3.32.1 Data input for module CLM:

Table 106: Structure (**descclm**)

```
[ EDIT iprint ]
MIXCLM (idclm(ii),ii=1,nclm)
[ { ADDI | SETI } { ABS | REL } (isot(ii) dens(ii),ii=1,niso) ]
;
```

where

**EDIT**            keyword used to modify the print level *iprint*.

*iprint*            index used to control the printing of this module. The amount of output produced by this module will vary substantially depending on the print level specified.

**MIXCLM**        keyword to specify that several liquid mixtures will be combined to replace the original mixtures. This combination will take into account the volume occupied by each mixture.

**idclm**            mixture number to combine.

**ADDI**            to add a isotope concentration to that of this isotope in the combined mixture,

**SETI**            to set the concentration of an isotope in the combined mixture to a fix value.

**ABS**            isotopic concentration in  $10^{24} \text{ cm}^{-3}$ .

**REL**            relative concentration with respect with the concentration of an isotope in the combined mixture.

isot           reference name of isotope to process.  
dens           absolute or relative density for this isotope.



## 4 THE RESONANCE SELF-SHIELDING MODULES

A few DRAGON modules are dedicated to include resonance self-shielding effects in MICROLIB and MACROLIB structures. Module **VDG**: compute self-shielding discrepancy between a reference calculation based on the Autosecol method in module **AUTO**: and more approximate calculations.<sup>[107, 108]</sup>

### 4.1 The **SHI**: module

The **SHI**: module perform self-shielding calculations in DRAGON, using the generalized Stamm'ler method.<sup>[61]</sup> This approach is based on an heterogeneous-homogeneous equivalence principle. In this case, an *equivalent dilution parameter*  $\sigma_{e,g}$  is computed for each resonant isotope, in each resonant region and each resonant energy group  $g$ . This dilution parameter is used to interpolate pretabulated effective cross sections for the infinite homogeneous medium, previously obtained with the *flux calculator* of the **GROUPR** module in code **NJOY**.<sup>[62]</sup> Each resonant isotope, identified as such by the *inrs* parameter defined in Section 3.2, is to be recalculated. The general format of the data for this module is:

Table 107: Structure (**SHI**:)

```
MICLIB := SHI: { MICLIB | OLDLIB } TRKNAM [ TRKFIL ] :: (descshi)
```

where

|                  |   |
|------------------|---|
| <i>MICLIB</i>    | <b>character*12</b> name of the MICROLIB that will contain the microscopic and macroscopic cross sections updated by the self-shielding module. If <i>MICLIB</i> appears on both LHS and RHS, it is updated; otherwise, the internal library <i>OLDLIB</i> is copied into <i>MICLIB</i> and <i>MICLIB</i> is updated. |
| <i>OLDLIB</i>    | <b>character*12</b> name of a read-only MICROLIB that is copied into <i>MICLIB</i> .  |
| <i>TRKNAM</i>    | <b>character*12</b> name of the required TRACKING data structure.   |
| <i>TRKFIL</i>    | <b>character*12</b> name of the sequential binary tracking file used to store the tracks lengths. This file is given if and only if it was required in the previous tracking module call (see Section 3.4).   |
| <b>(descshi)</b> | structure describing the self-shielding options.  |

Each time the **SHI**: module is called, a sub-directory is updated in the MICROLIB data structure to hold the last values defined in the **(descshi)** structure. The next time this module is called, these values will be used as floating defaults.

#### 4.1.1 Data input for module **SHI**:

Table 108: Structure (**descshi**)

```
[ EDIT iprint ]  
[ GRMIN lgrmin ] [ GRMAX lgrmax ]
```

continued on next page

Structure (**descshi**)

continued from last page

```
[ MXIT imxit ] [ EPS valeps ]
[ { LJ | NOLJ } ] [ { GC | NOGC } ] [ { TRAN | NOTR } ] [ LEVEL ilev ]
[ { PIJ | ARM } ]
;
```

where

|               |  |
|---------------|--|
| EDIT          | keyword used to modify the print level <i>iprint</i> .   |
| <i>iprint</i> | index used to control the printing of this module. The amount of output produced by this tracking module will vary substantially depending on the print level specified.   |
| GRMIN         | keyword to specify the minimum group number considered during the self-shielding process.  |
| <i>lgrmin</i> | first group number considered during the self-shielding process. By default, <i>lgrmin</i> is set to the first group number containing self-shielding data in the library.   |
| GRMAX         | keyword to specify the maximum group number considered during the self-shielding process.  |
| <i>lgrmax</i> | last group number considered during the self-shielding process. By default, <i>lgrmax</i> is set to the last group number containing self-shielding data in the library.   |
| MXIT          | keyword to specify the maximum number of iterations during the self-shielding process.   |
| <i>imxit</i>  | the maximum number of iterations. The default is <i>imxit</i> =20.   |
| EPS           | keyword to specify the convergence criterion for the self-shielding iteration.   |
| <i>valeps</i> | the convergence criterion for the self-shielding iteration. By default, <i>valeps</i> = $1.0 \times 10^{-4}$ .   |
| LJ            | keyword to activate the Livolant and Jeanpierre normalization scheme which modifies the self-shielded averaged neutron fluxes in heterogeneous geometries. By default the Livolant and Jeanpierre normalization scheme is not activated.   |
| NOLJ          | keyword to deactivate the Livolant and Jeanpierre normalization scheme which modifies the self-shielded averaged neutron fluxes in heterogeneous geometries. This is the default option.   |
| GC            | keyword to activate the Goldstein-Cohen approximation in cases where Goldstein-Cohen parameters are stored on the internal library. These parameters may not be available with some libraries (e.g., APLIB1, APLIB2 or MATXS-type libraries). The Goldstein-Cohen parameters can always be imposed using the IRSET keyword of the LIB: module (see Section 3.2). This is the default option. |
| NOGC          | keyword to deactivate the Goldstein-Cohen approximation in cases where Goldstein-Cohen parameters are stored on the internal library.  |
| TRAN          | keyword to activate the transport correction option for self-shielding calculations (see CTRA in Sections 3.1 and 3.2). This is the default option.  |
| NOTR          | keyword to deactivate the transport correction option for self-shielding calculations (see CTRA in Sections 3.1 and 3.2).  |
| LEVEL         | keyword to specify the self-shielding model.   |

- ilev* = 0: original Stamm'ler model (without distributed effects); = 1: use the Nordheim (PIC) distributed self-shielding model<sup>[64]</sup>; = 2: use both Nordheim (PIC) distributed self-shielding model and Riemann integration method<sup>[65]</sup>. By default, *ilev* = 0.
- PIJ keyword to specify the use of complete collision probabilities in the self-shielding calculations of SHI:. This is the default option for EXCELT: and SYBILT: trackings. This option is not available for MCCGT: trackings.
- ARM keyword to specify the use of iterative flux techniques in the self-shielding calculations of SHI:. This is the default option for MCCGT: trackings.

## 4.2 The TONE: module

The TONE: module perform self-shielding calculations in DRAGON, using the Tone's method.<sup>[63]</sup> This approach is based on an heterogeneous-homogeneous equivalence principle. In this case, an *equivalent dilution parameter*  $\sigma_{e,g}$  is computed for each resonant isotope, in each resonant region and each resonant energy group  $g$ . This dilution parameter is used to interpolate pretabulated effective cross sections for the infinite homogeneous medium, previously obtained with the *flux calculator* of the GROUPR module in code NJOY.<sup>[62]</sup> Each resonant isotope, identified as such by the *inrs* parameter defined in Section 3.2, is to be recalculated. The general format of the data for this module is:

Table 109: Structure (TONE:)

```
MICLIB := TONE: { MICLIB | OLDLIB } TRKNAM [ TRKFIL ] :: (descstone)
```

where

**MICLIB**      **character\*12** name of the MICROLIB that will contain the microscopic and macroscopic cross sections updated by the self-shielding module. If *MICLIB* appears on both LHS and RHS, it is updated; otherwise, the internal library *OLDLIB* is copied into *MICLIB* and *MICLIB* is updated.

**OLDLIB**      **character\*12** name of a read-only MICROLIB that is copied into *MICLIB*.

**TRKNAM**      **character\*12** name of the required TRACKING data structure.

**TRKFIL**      **character\*12** name of the sequential binary tracking file used to store the tracks lengths. This file is given if and only if it was required in the previous tracking module call (see Section 3.4).

**(descstone)**      structure describing the self-shielding options.

Each time the TONE: module is called, a sub-directory is updated in the MICROLIB data structure to hold the last values defined in the **(descstone)** structure. The next time this module is called, these values will be used as floating defaults.

### 4.2.1 Data input for module TONE:

Table 110: Structure (descstone)

```
[ EDIT iprint ]
[ GRMIN lgrmin ] [ GRMAX lgrmax ]
[ MXIT imxit ] [ EPS valeps ]
[ { SPH | NOSP } ] [ { TRAN | NOTR } ] [ { PIJ | ARM } ]
;
```

where

**EDIT**              keyword used to modify the print level *iprint*.

|               |  |
|---------------|--|
| <i>iprint</i> | index used to control the printing of this module. The amount of output produced by this tracking module will vary substantially depending on the print level specified.   |
| GRMIN         | keyword to specify the minimum group number considered during the self-shielding process.  |
| <i>lgrmin</i> | first group number considered during the self-shielding process. By default, <i>lgrmin</i> is set to the first group number containing self-shielding data in the library.   |
| GRMAX         | keyword to specify the maximum group number considered during the self-shielding process.  |
| <i>lgrmax</i> | last group number considered during the self-shielding process. By default, <i>lgrmax</i> is set to the last group number containing self-shielding data in the library.   |
| MXIT          | keyword to specify the maximum number of iterations during the self-shielding process.   |
| <i>imxit</i>  | the maximum number of iterations. The default is <i>imxit</i> =20.   |
| EPS           | keyword to specify the convergence criterion for the self-shielding iteration.   |
| <i>valeps</i> | the convergence criterion for the self-shielding iteration. By default, <i>valeps</i> = $1.0 \times 10^{-4}$ .   |
| SPH           | keyword to activate the SPH equivalence scheme which modifies the self-shielded averaged neutron fluxes in heterogeneous geometries. This is the default option.   |
| NOSP          | keyword to deactivate the SPH equivalence scheme which modifies the self-shielded averaged neutron fluxes in heterogeneous geometries.   |
| TRAN          | keyword to activate the transport correction option for self-shielding calculations (see CTRA in Sections 3.1 and 3.2). This is the default option.  |
| NOTR          | keyword to deactivate the transport correction option for self-shielding calculations (see CTRA in Sections 3.1 and 3.2).  |
| PIJ           | keyword to specify the use of complete collision probabilities in the self-shielding calculations of TONE:. This is the default option for EXCELT: and SYBILT: trackings. This option is not available for MCCGT: trackings. |
| ARM           | keyword to specify the use of iterative flux techniques in the self-shielding calculations of TONE:. This is the default option for MCCGT: trackings.  |

### 4.3 The USS: module

The universal self-shielding module in DRAGON, called `USS:`, allows the correction of the microscopic cross sections to take into account the self-shielding effects related to the resonant isotopes. These isotopes are identified as such by the `inrs` parameter, as defined in Section 3.2. The universal self-shielding module is based on the following models:

- The Livolant-Jeanpierre flux factorization and approximations are used to uncouple the self-shielding treatment from the main flux calculation;
- The resonant cross sections are represented using probability tables computed in the `LIB:` module (the keyword `SUBG` or `PTSL` *must* be used). Two approaches can be used to compute the probability tables:
  1. Physical probability tables can be computed using a RMS approach similar to the one used in Wims-7 and Helios.<sup>[12]</sup> In this case, the slowing-down operator of each resonant isotope is represented as a pure `ST`<sup>[18]</sup>, `ST/IR` or `ST/WR` approximation;
  2. Mathematical probability tables<sup>[13]</sup> and slowing-down correlated weight matrices can be computed in selected energy groups using the *Ribon extended* approach.<sup>[14]</sup> In this case, an elastic slowing-down model is used and a mutual self-shielding model is available.
- The resonant fluxes are computed for each band of the probability tables using a subgroup method if `SUBG`, `PT`, `PTMC` or `PTSL` keyword is set in module `LIB:`;
- The resonance spectrum expansion (RSE) method is used if `RSE` keyword is set in module `LIB:`;
- The flux can be solved using collision probabilities, or using *any* flux solution technique for which a tracking module is available;
- The resonant isotopes are computed one-a-time, starting from the isotopes with the lower values of index `inrs`, as defined in Section 3.2; If many isotopes have the same value of `inrs`, the isotope with the greatest number of resonant nuclides is self-shielded first. One or many outer iterations can be performed;
- The distributed self-shielded effect is automatically taken into account if different mixture indices are assigned to different regions inside the resonant part of the cell. The rim effect can be computed by dividing the fuel into "onion rings" and by assigning different mixture indices to them.
- A SPH (superhomogénéisation) equivalence is performed to correct the self-shielded cross sections from the non-linear effects related to the heterogeneity of the geometry.

The general format of the data for this module is:

Table 111: Structure (`USS:`)

```
MICLIB := USS: MICLIB_SG [ MICLIB ] TRKNAM [ TRKFIL ] :: (descuss)
```

where

|                        |  |
|------------------------|--|
| <code>MICLIB</code>    | <code>character*12</code> name of the <code>MICROLIB</code> that will contain the microscopic and macroscopic cross sections updated by the self-shielding module. If <code>MICLIB</code> appears on both LHS and RHS, it is updated; otherwise, <code>MICLIB</code> is created. |
| <code>MICLIB_SG</code> | <code>character*12</code> name of the <code>MICROLIB</code> builded by module <code>LIB:</code> and containing probability table information (the keyword <code>SUBG</code> <i>must</i> be used in module <code>LIB:</code> ).   |

|                  |   |
|------------------|---|
| <i>TRKNAM</i>    | <b>character*12</b> name of the required TRACKING data structure.   |
| <i>TRKFIL</i>    | <b>character*12</b> name of the sequential binary tracking file used to store the tracks lengths. This file is given if and only if it was required in the previous tracking module call (see Section 3.4). |
| <b>(descuss)</b> | structure describing the self-shielding options.  |

Each time the **USS**: module is called, a sub-directory is updated in the MICROLIB data structure to hold the last values defined in the **(descuss)** structure. The next time this module is called, these values will be used as floating defaults.

#### 4.3.1 Data input for module USS:

Table 112: Structure **(descuss)**

```
[ EDIT iprint ]
[ GRMIN lgrmin ] [ GRMAX lgrmax ] [ PASS ipass ] [ NOCO ] [ NOSP ] [ { TRAN | NOTR } ]
[ { PIJ | ARM } ]
[ MAXST imax ] [ FLAT ]
[ CALC
  [[ REGI suffix [[ isot { ALL | (imix(i),i=1,nmix) } ] ]
  ]]
[ ENDC ]
;
```

where

|               |   |
|---------------|---|
| <b>EDIT</b>   | keyword used to modify the print level <i>iprint</i> .  |
| <i>iprint</i> | index used to control the printing of this module. The amount of output produced by this tracking module will vary substantially depending on the print level specified.  |
| <b>GRMIN</b>  | keyword to specify the minimum group number considered during the self-shielding process.   |
| <i>lgrmin</i> | first group number considered during the self-shielding process. By default, <i>lgrmin</i> is set to the first group number containing self-shielding data in the library.  |
| <b>GRMAX</b>  | keyword to specify the maximum group number considered during the self-shielding process.   |
| <i>lgrmax</i> | last group number considered during the self-shielding process. By default, <i>lgrmax</i> is set to the last group number containing self-shielding data in the library.  |
| <b>PASS</b>   | keyword to specify the number of outer iterations during the self-shielding process.  |
| <i>ipass</i>  | the number of iterations. The default is <i>ipass</i> = 2 if <i>MICLIB</i> is created.  |
| <b>NOCO</b>   | keyword to ignore the directives set by <b>LIB</b> concerning the mutual resonance shielding model. This keyword has the effect to replace the mutual resonance shielding model in the subgroup projection method (SPM) by a full correlation approximation similar to the technique used in the ECCO code. This keyword can be used to avoid the message |

USSIST: UNABLE TO FIND CORRELATED ISOTOPE \*\*\*\*\*.

that appears with the SPM if the correlated weights matrices are missing in the microlib.

|               |   |
|---------------|---|
| NOSP          | keyword to deactivate the SPH equivalence scheme which modifies the self-shielded averaged neutron fluxes in heterogeneous geometries. The default option is to perform SPH equivalence.  |
| TRAN          | keyword to activate the transport correction option for self-shielding calculations (see CTRA in Sections 3.1 and 3.2). This is the default option.   |
| NOTR          | keyword to deactivate the transport correction option for self-shielding calculations (see CTRA in Sections 3.1 and 3.2).   |
| PIJ           | keyword to specify the use of complete collision probabilities in the subgroup and SPH equivalence calculations of USS:. This is the default option for EXCELT: and SYBILT: trackings. This option is not available for MCCGT: trackings. |
| ARM           | keyword to specify the use of iterative flux techniques in the subgroup and SPH equivalence calculations of USS:. This is the default option for MCCGT: trackings.  |
| MAXST         | keyword to set the maximum number of fixed point iterations for the ST scattering source convergence.   |
| <i>imax</i>   | the maximum number of ST iterations. The default is <i>imax</i> = 50 (= 20 with the RSE method). A non-iterative response matrix approach is available with the subgroup projection method (SPM) by setting <i>imax</i> = 0.              |
| FLAT          | keyword to force the flat-flux initialization of subgroup fluxes if MICLIB is open in modification mode.  |
| CALC          | keyword to activate the simplified self-shielding approximation in which a single self-shielded isotope is shared by many resonant mixtures.  |
| REGI          | keyword to specify a set of isotopes and mixtures that will be self-shielded together. All the self-shielded isotopes in this group will share the same 4-digit suffix.   |
| <i>suffix</i> | character*4 suffix for the isotope names in this group  |
| <i>isot</i>   | character*8 alias name of a self-shielded isotope in this group   |
| ALL           | keyword to specify that a unique self-shielded isotope will be made for the complete domain   |
| <i>imix</i>   | list of mixture indices that will share the same self-shielded isotope  |
| <i>nmix</i>   | number of mixtures that will share the same self-shielded isotope   |
| ENDC          | end of CALC data keyword  |

Here is an example of the data structure corresponding to a production case where only  $^{238}\text{U}$  is assumed to show distributed self-shielding effects:

```

LIBRARY2 := USS: LIBRARY TRACK ::
  CALC REGI W1 PU239 ALL
    REGI W1 PU241 ALL
    REGI W1 PU240 ALL
    REGI W1 PU242 ALL
    REGI W1 U235 ALL
    REGI W1 U236 ALL

```



```

REGI W1 PU238 ALL
REGI W1 U234 ALL
REGI W1 AM241 ALL
REGI W1 NP237 ALL
REGI W1 ZRNAT ALL
REGI W1 U238 <<COMB0101>> <<COMB0201>> <<COMB0301>>
                <<COMB0401>> <<COMB0501>>
REGI W2 U238 <<COMB0102>> <<COMB0202>> <<COMB0302>>
                <<COMB0402>> <<COMB0502>>
REGI W3 U238 <<COMB0103>> <<COMB0203>> <<COMB0303>>
                <<COMB0403>> <<COMB0503>>
REGI W4 U238 <<COMB0104>> <<COMB0204>> <<COMB0304>>
                <<COMB0404>> <<COMB0504>>
REGI W5 U238 <<COMB0105>> <<COMB0205>> <<COMB0305>>
                <<COMB0405>> <<COMB0505>>
REGI W6 U238 <<COMB0106>> <<COMB0206>> <<COMB0306>>
                <<COMB0406>> <<COMB0506>>

```

ENDC ;

In this case,  $^{238}\text{U}$  is self-shielded within six distributed regions (labeled W1 to W6) and each of these regions are merging volumes belonging to five different fuel rods. The mixture indices of the 30 resonant volumes belonging to the fuel are CLE-2000 variables labeled <<COMB0101>> to <<COMB0506>>.

#### 4.4 The AUTO: module

The Autosecol self-shielding module in DRAGON, called **AUTO:**, allows the correction of the microscopic cross sections to take into account the self-shielding effects related to the resonant isotopes.<sup>[107]</sup>

*Autolib data* is a fine-group representation of microscopic cross-section data for the resonant isotopes available in a *Draglib* or *APOLIB-2* cross-section library. Each fine group in the Autolib has a lethargy width which is an integer multiple of an *elementary lethargy width*. Elastic slowing-down scattering is assumed for the resonant isotopes.

Integrating the Livolant-Jeanpierre equation over a fine group  $g$ , the Autosecol equation is written

$$\boldsymbol{\Omega} \cdot \nabla \varphi_g(\mathbf{r}, \boldsymbol{\Omega}) + \Sigma_g(\mathbf{r}) \varphi_g(\mathbf{r}, \boldsymbol{\Omega}) = \frac{1}{4\pi} \left[ \Sigma_{s,g}^+(\mathbf{r}) + \sum_h \Sigma_{s,j,g \leftarrow h}^* \varphi_h(\mathbf{r}) \frac{\Delta u_h}{\Delta u_g} \right] \quad (4.1)$$

where the group integrated fine structure function is written

$$\varphi_g(\mathbf{r}) = \frac{1}{\Delta u_g} \int_{u_{g-1}}^{u_g} du \varphi(\mathbf{r}, u) \quad (4.2)$$

and where the  $+$  and  $*$  subscripts identify non-resonant and resonant isotopes respectively.

The *Autosecol method* consists to solve the Livolant-Jeanpierre equation over the Autolib energy mesh using a solution technique of the Boltzmann transport equation available in DRAGON.<sup>[1]</sup> The Autosecol method is an accurate self-shielding technique relying on the fine-group solution of an heterogeneous transport equation. This approach may require substantial CPU resources in actual production cases.

Resonant isotopes are identified as such by the *inrs* parameter, as defined in Section 3.2. The Autosecol self-shielding module is based on the following models:

- The Livolant-Jeanpierre flux factorization and approximations are used to uncouple the self-shielding treatment from the main flux calculation;
- The resonant cross sections are represented using *Autolib data* recovered by the **LIB:** module.
- Probability tables are used in the unresolved energy domain to randomly sample cross-section data into the Autolib fine mesh. The keyword **SUBG** *must* be set in module **LIB:**.
- The resonant fine structure values  $\varphi_g(\mathbf{r})$  are obtained as a solution of the Autosecol Eq. (4.1) over the Autolib fine mesh;
- The flux can be solved using collision probabilities, or using *any* flux solution technique for which a tracking module is available;
- All resonant isotopes with the same *inrs* index (see Sect. 3.2.3) are computed simultaneously;
- The distributed self-shielded effect is automatically taken into account if different mixture indices are assigned to different regions inside the resonant part of the cell. The rim effect can be computed by dividing the fuel into "onion rings" and by assigning different mixture indices to them.
- A SPH (superhomogénéisation) equivalence is performed to correct the self-shielded cross sections from the non-linear effects related to the heterogeneity of the geometry.

The general format of the data for this module is:

Table 113: Structure (**AUTO:**)

|   |
|---|
| <code>MICLIB := AUTO: MICLIB_SG [ MICLIB ] TRKNAM [ TRKFIL ] :: (descauto)</code> |
|---|

where

|                   |   |
|-------------------|---|
| <i>MICLIB</i>     | <b>character*12</b> name of the MICROLIB that will contain the microscopic and macroscopic cross sections updated by the self-shielding module. If <i>MICLIB</i> appears on both LHS and RHS, it is updated; otherwise, <i>MICLIB</i> is created. |
| <i>MICLIB_SG</i>  | <b>character*12</b> name of the MICROLIB builded by module LIB: and containing probability table information for the unresolved domain.   |
| <i>TRKNAM</i>     | <b>character*12</b> name of the required TRACKING data structure.   |
| <i>TRKFIL</i>     | <b>character*12</b> name of the sequential binary tracking file used to store the tracks lengths. This file is given if and only if it was required in the previous tracking module call (see Section 3.4).                                       |
| <b>(descauto)</b> | structure describing the self-shielding options.  |

#### 4.4.1 Data input for module AUTO:

Table 114: Structure **(descauto)**

```
[ EDIT iprint ]
[ GRMIN lgrmin ] [ GRMAX lgrmax ] [ PASS ipass ] [ { SPH | NOSP } ] [ { TRAN | NOTR } ]
[ { PIJ | ARM } ]
[[ DILU isot_d dilut ]]
[ KERN ialter ] [ MAXT maxtra ]
[ SEED iseed ]
[ CALC
  [[ REGI suffix [[ isot { ALL | (imix(i),i=1,nmix) } ] ] ] ] ]
ENDC ]
;
```

where

|               |  |
|---------------|--|
| EDIT          | keyword used to modify the print level <i>iprint</i> .   |
| <i>iprint</i> | index used to control the printing of this module. The amount of output produced by this tracking module will vary substantially depending on the print level specified.   |
| GRMIN         | keyword to specify the minimum group number considered during the self-shielding process.  |
| <i>lgrmin</i> | first group number considered during the self-shielding process. By default, <i>lgrmin</i> is set to the first group number containing self-shielding data in the library. |
| GRMAX         | keyword to specify the maximum group number considered during the self-shielding process.  |
| <i>lgrmax</i> | last group number considered during the self-shielding process. By default, <i>lgrmax</i> is set to the last group number containing self-shielding data in the library.   |

|               |  |
|---------------|--|
| PASS          | keyword to specify the number of outer iterations during the self-shielding process. If all <i>inrs</i> indices are set to one in module LIB:, these iterations are not required.  |
| <i>ipass</i>  | the number of iterations. The default is <i>ipass</i> = 1 if <i>MICLIB</i> is created.   |
| SPH           | keyword to activate the SPH equivalence scheme which modifies the self-shielded averaged neutron fluxes in heterogeneous geometries (default option).  |
| NOSP          | keyword to deactivate the SPH equivalence scheme which modifies the self-shielded averaged neutron fluxes in heterogeneous geometries.   |
| TRAN          | keyword to activate the transport correction option for self-shielding calculations (see CTRA in Sections 3.1 and 3.2). This is the default option.  |
| NOTR          | keyword to deactivate the transport correction option for self-shielding calculations (see CTRA in Sections 3.1 and 3.2).  |
| PIJ           | keyword to specify the use of complete collision probabilities in the subgroup and SPH equivalence calculations of AUTO:. This is the default option for EXCELT: and SYBILT: trackings. This option is not available for MCCGT: trackings. |
| ARM           | keyword to specify the use of iterative flux techniques in the subgroup and SPH equivalence calculations of AUTO:. This is the default option for MCCGT: trackings.  |
| DILU          | keyword to input an additional microscopic dilution value for a specific isotope. By default, no dilution source other than $\Sigma_{s,g}^+(\mathbf{r})$ is used.  |
| <i>isot_d</i> | character*8 alias name of the specific isotope.  |
| <i>dilut</i>  | dilution value in barn.  |
| KERN          | keyword to input the type of elastic slowing-down kernel.  |
| <i>ialter</i> | integer value indicating the type: $ialter = \begin{cases} 0 & \text{use exact elastic kernel} \\ 1 & \text{use an approximate kernel for the resonant isotopes.} \end{cases}$   |
| MAXT          | keyword to input a maximum storage size for the slowing-down kernel values.  |
| <i>maxtra</i> | integer value indicating the storage size. The default value is <i>maxtra</i> = 10000.   |
| SEED          | keyword used to set the initial seed integer for the random number generator used in the unresolved energy domain. By default, the seed integer is set from the processor clock.   |
| <i>iseed</i>  | initial seed integer.  |
| CALC          | keyword to activate the simplified self-shielding approximation in which a single self-shielded isotope is shared by many resonant mixtures.   |
| REGI          | keyword to specify a set of isotopes and mixtures that will be self-shielded together. All the self-shielded isotopes in this group will share the same 4-digit suffix.  |
| <i>suffix</i> | character*4 suffix for the isotope names in this group   |
| <i>isot</i>   | character*8 alias name of a self-shielded isotope in this group  |
| ALL           | keyword to specify that a unique self-shielded isotope will be made for the complete domain  |
| <i>imix</i>   | list of mixture indices that will share the same self-shielded isotope   |
| <i>nmix</i>   | number of mixtures that will share the same self-shielded isotope  |

ENDC                   end of CALC data keyword

Here is an example of the data structure corresponding to a production case where only  $^{238}\text{U}$  is assumed to show distributed self-shielding effects:

```

LIBRARY2 := AUTO: LIBRARY TRACK ::
  CALC REGI W1 PU239 ALL
    REGI W1 PU241 ALL
    REGI W1 PU240 ALL
    REGI W1 PU242 ALL
    REGI W1 U235 ALL
    REGI W1 U236 ALL
    REGI W1 PU238 ALL
    REGI W1 U234 ALL
    REGI W1 AM241 ALL
    REGI W1 NP237 ALL
    REGI W1 ZRNAT ALL
    REGI W1 U238 <<COMB0101>> <<COMB0201>> <<COMB0301>>
      <<COMB0401>> <<COMB0501>>
    REGI W2 U238 <<COMB0102>> <<COMB0202>> <<COMB0302>>
      <<COMB0402>> <<COMB0502>>
    REGI W3 U238 <<COMB0103>> <<COMB0203>> <<COMB0303>>
      <<COMB0403>> <<COMB0503>>
    REGI W4 U238 <<COMB0104>> <<COMB0204>> <<COMB0304>>
      <<COMB0404>> <<COMB0504>>
    REGI W5 U238 <<COMB0105>> <<COMB0205>> <<COMB0305>>
      <<COMB0405>> <<COMB0505>>
    REGI W6 U238 <<COMB0106>> <<COMB0206>> <<COMB0306>>
      <<COMB0406>> <<COMB0506>>
  ENDC ;

```

In this case,  $^{238}\text{U}$  is self-shielded within six distributed regions (labeled W1 to W6) and each of these regions are merging volumes belonging to five different fuel rods. The mixture indices of the 30 resonant volumes belonging to the fuel are CLE-2000 variables labeled <<COMB0101>> to <<COMB0506>>.

#### 4.5 The VDG: module

The VDG: module performs a comparison of an approximate self-shielding method with the Autosecol method. This module is useful to obtain accuracy results for the Van Der Gucht benchmarks.<sup>[108]</sup> The calling specifications are:

Table 115: Structure (VDG:)

```
VDG: MICLIB1 MICLIB2 :: (descvdg)
```

where

|                    |  |
|--------------------|--|
| <i>MICLIB1</i>     | <b>character*12</b> name of the self-shielded MICROLIB produced by the Autosecol method (module AUTO:).  |
| <i>MICLIB2</i>     | <b>character*12</b> name of the self-shielded MICROLIB produced by an approximate self-shielding method. |
| ( <b>descvdg</b> ) | structure describing the VDG: module options.  |

##### 4.5.1 Data input for module VDG:

Table 116: Structure (descvdg)

```
[ EDIT iprint ]
[ GRMI igrp1 ] [ GRMA igrp2 ]
[ PICK { MAXV | AVER | INTG } >> error << ]
;
```

where

|               |   |
|---------------|---|
| EDIT          | keyword used to modify the print level <i>iprint</i> .  |
| <i>iprint</i> | index used to control the printing of this module. The amount of output produced by this module will vary substantially depending on the print level specified. |
| GRMI          | keyword used to set the index of the first group in the microlib. By default, GRMI = 1.   |
| <i>igrp1</i>  | index of the first resonant group.  |
| GRMA          | keyword used to set the index of the last group in the microlib. By default, GRMA = 9999999.  |
| <i>igrp2</i>  | index of the last resonant group.   |
| PICK          | keyword used to recover a relative discrepancy value for the absorption rates in each DRAGON resonant energy group.   |
| MAXV          | keyword to select the maximum relative discrepancy.   |
| AVER          | keyword to select the averaged relative discrepancy.  |

INTG keyword to select the integrated relative discrepancy.

error character\*12 CLE-2000 variable name in which the extracted percent discrepancy value will be placed.

## 5 THE SALOME-RELATED MODULES

A few modules have been introduced in DRAGON Version5 in order to facilitate the processing of geometries originating from the Geometry module of SALOME.<sup>[109]</sup> The methods presented in this section have been initially developed at CEA SERMA and integrated in the TDT code.<sup>[110,111]</sup> In the course of year 2001, a subset of these methods have been integrated into a development version of DRAGON under the terms of its LGPL license as a prototyping exercise of the DESCARTES operation.<sup>[112]</sup>

The track generator **SALT:** is a direct descendent of this prototyping exercise. Later, we have extracted the 5000 lines of Fortran-90 code responsible for the track calculation and have rewritten them in a way consistent with the **NXT:** tracking methodology and with the DRAGON architecture.

The **SALT:** module can process two types of geometries:

- *Native geometries* are those defined using the **GEO:** module and transformed into surfacic geometries using the **G2S:** module. These geometries have many limitations related to their definition.
- *Non-native geometries* are surfacic representations based on extensions of the SALOME platform. A first extension is the SALOMON tool presented in Ref. 113. ALAMOS is a more recent tool available at the Commissariat à l'Énergie Atomique.<sup>[114]</sup> Surfacic geometries produced by ALAMOS must be converted to the SALOMON format using the **G2S:** module before calling the track generator **SALT:**.

### 5.1 The G2S: module

The module **G2S:** is used to create the SALOMON-formatted surfacic elements corresponding to a gigue geometry. It can also be used to plot a SALOMON-formatted file or as a conversion tool to transform an ALAMOS-formatted file into a SALOMON-formatted file. The general format of the input data for the **G2S:** module is the following:

Table 117: Structure (**G2S:**)

```
[ SURFIL ] [ PSFIL ] := G2S: { SURFIL_IN [ ZAFIL_IN ] | GEONAM } :: (G2S_data)
```

where

|                  |   |
|------------------|---|
| <i>SURFIL</i>    | <b>character*12</b> name of the output SALOMON-formatted sequential ASCII file used to store the surfacic elements of the geometry.   |
| <i>PSFIL</i>     | <b>character*12</b> name of the sequential ASCII file used to store a postscript representation of the geometry corresponding to <i>SURFIL</i> or <i>GEONAM</i> .   |
| <i>GEONAM</i>    | <b>character*12</b> name of the <i>read-only</i> GEOMETRY data structure. This structure may be build using the operator <b>GEO:</b> (see Section 3.3).   |
| <i>SURFIL_IN</i> | <b>character*12</b> name of the input SALOMON- or ALAMOS-formatted sequential ASCII file used to store the surfacic elements of the geometry.   |
| <i>ZAFIL_IN</i>  | <b>character*12</b> name of the input sequential ASCII file containing <i>PropertyMap</i> information associated with the ALAMOS geometry. This file generally has a <i>.za</i> extension. This information is used to set node-ordered mixture indices. By default, node-ordered mixture indices are recovered from the <i>Mailles</i> record present in the ALAMOS surfacic file. |
| <i>G2S_data</i>  | input data structure containing specific data (see Section 5.1.1).  |



## 5.1.1 Data input for module G2S:

Table 118: Structure (**G2S\_data**)

```
[ EDIT iprint ]
[ ALAMOS typgeo ]
[ { DRAWNOD | DRAWMIX } ] [ ZOOMX facx1 facx2 ] [ ZOOMY facy1 facy2 ]
;
```

where

**EDIT** keyword used to set *iprint*.

*iprint* index used to control the printing in module **G2S**:. =0 for no print; =1 for minimum printing (default value).

**ALAMOS** keyword to use **G2S**: as a conversion tool to transform an ALAMOS-formatted file into a SALOMON-formatted file.

*typgeo* type of Alamos geometry. A negative value is used for isotropic reflection (white boundary condition) with unfolding in **SALT**: module. Otherwise, a specular boundary condition is used without unfolding.

$$typgeo = \left\{ \begin{array}{ll} 0 & \text{Isotropic reflection (white boundary condition) without perimeter information} \\ \pm 5 & \text{Cartesian rectangular geometry with translation} \\ \pm 6 & \text{Cartesian rectangular geometry with specular reflection on each side} \\ \pm 7 & \text{Cartesian eight-of-square geometry with specular reflection on each side} \\ \pm 8 & \text{Hexagonal SA60 equilateral triangle geometry with specular reflection on each side} \\ \pm 9 & \text{Full hexagonal geometry with translation} \\ \pm 10 & \text{Hexagonal RA60 equilateral triangle geometry with } 60^\circ \text{ rotation and translation} \\ \pm 11 & \text{Hexagonal R120 lozenge geometry with } 120^\circ \text{ rotation and translation.} \end{array} \right.$$

**DRAWNOD** keyword used to print the region indices on the LHS postscript plot *PSFIL*. By default, no indices are printed.

**DRAWMIX** keyword used to print the material mixture indices on the LHS postscript plot *PSFIL*. By default, no indices are printed.

**ZOOMX** keyword used to plot a fraction of the *X*-domain. By default, all the *X*-domain is plotted.

*facx1* left factor set in interval  $0.0 \leq facx1 < 1.0$  with 0.0 corresponding to the left boundary and 1.0 corresponding to the right boundary.

*facx2* right factor set in interval  $facx1 < facx2 \leq 1.0$ .

**ZOOMY** keyword used to plot a fraction of the *Y*-domain. By default, all the *Y*-domain is plotted.

*facy1* lower factor set in interval  $0.0 \leq facy1 < 1.0$  with 0.0 corresponding to the lower boundary and 1.0 corresponding to the upper boundary.

*facy2* upper factor set in interval  $facy1 < facy2 \leq 1.0$ .

## 5.2 The G2MC: module

The module `G2MC:` is used to compute the SERPENT-, TRIPOLI4-, or MCNP-formatted surfacic elements corresponding to a SALOMON-formatted file or corresponding to a gigogne geometry. The general format of the input data for the `G2MC:` module is the following:

Table 119: Structure (`G2MC:`)

```
MCFIL [ PSFIL ] := G2MC: { SURFIL | GEONAM } :: (G2MC_data)
```

where

|                  |  |
|------------------|--|
| <i>MCFIL</i>     | <code>character*12</code> name of the SERPENT-, TRIPOLI4- or MCNP-formatted sequential ASCII file used to store the surfacic elements of the geometry. A SERPENT file is produced if the file name has extension ".sp". A TRIPOLI4 file is produced if the file name has extension ".tp". Otherwise, a MCNP file is produced. This file is to be included in the complete dataset of a Monte Carlo code. |
| <i>PSFIL</i>     | <code>character*12</code> name of the sequential ASCII file used to store a postscript representation of the geometry corresponding to <i>GEONAM</i> .   |
| <i>SURFIL</i>    | <code>character*12</code> name of the <i>read-only</i> SALOMON-formatted sequential ASCII file used to store the surfacic elements of the geometry.  |
| <i>GEONAM</i>    | <code>character*12</code> name of the <i>read-only</i> GEOMETRY data structure. This structure may be build using the operator <code>GEO:</code> (see Section 3.3).  |
| <i>G2MC_data</i> | input data structure containing specific data (see Section 5.2.1).   |

### 5.2.1 Data input for module `G2MC:`

Table 120: Structure (`G2MC_data`)

```
[ EDIT iprint ]
[ { DRAWNOD | DRAWMIX } ] [ ZOOMX facx1 facx2 ] [ ZOOMY facy1 facy2 ]
;
```

where

|                      |  |
|----------------------|--|
| <code>EDIT</code>    | keyword used to set <i>iprint</i> .  |
| <i>iprint</i>        | index used to control the printing in module <code>G2MC:</code> . =0 for no print; =1 for minimum printing (default value).      |
| <code>DRAWNOD</code> | keyword used to print the region indices on the LHS postscript plot <i>PSFIL</i> . By default, no indices are printed.           |
| <code>DRAWMIX</code> | keyword used to print the material mixture indices on the LHS postscript plot <i>PSFIL</i> . By default, no indices are printed. |
| <code>ZOOMX</code>   | keyword used to plot a fraction of the <i>X</i> -domain. By default, all the <i>X</i> -domain is plotted.                        |

|              |  |
|--------------|--|
| <i>facx1</i> | left factor set in interval $0.0 \leq \text{facx1} < 1.0$ with 0.0 corresponding to the left boundary and 1.0 corresponding to the right boundary.   |
| <i>facx2</i> | right factor set in interval $\text{facx1} < \text{facx2} \leq 1.0$ .  |
| ZOOMY        | keyword used to plot a fraction of the <i>Y</i> -domain. By default, all the <i>Y</i> -domain is plotted.  |
| <i>facy1</i> | lower factor set in interval $0.0 \leq \text{facy1} < 1.0$ with 0.0 corresponding to the lower boundary and 1.0 corresponding to the upper boundary. |
| <i>facy2</i> | upper factor set in interval $\text{facy1} < \text{facy2} \leq 1.0$ .  |

### 5.3 The SALT: tracking module

The SALT: module can process general 2-D geometries defined from *surfacic elements*. It is used to compute the tracking information requested in the method of collision probabilities or in the method of characteristics.

#### 5.3.1 Cyclic tracking

The SALT: module with keyword TSPC has the capability to perform *cyclic tracking* over a closed square, rectangular or equilateral triangular domain. Each track cover a certain surface before going back to the starting point after a distance  $L$ , as depicted in Figs. 25 and 26. Only specific angles, function of integer values  $n$  and  $m$ , make possible the cycling of trajectories.

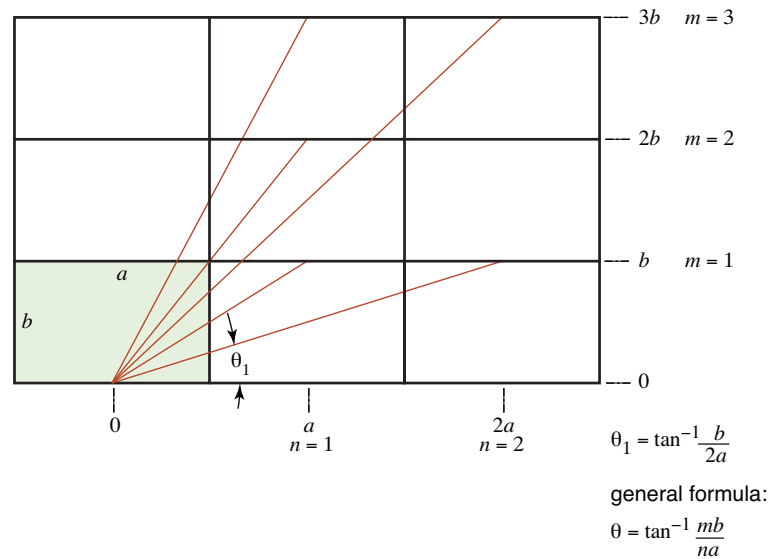

Figure 25: Cycling tracking over a Cartesian domain.

#### 5.3.2 Calling specifications

The calling specification for this module is:

Table 121: Structure (SALT:)

```
TRKNAM TRKFIL := SALT: SURFIL [ GEONAM ] :: (desctrack) (descsalt)
```

where

**TRKNAM** character\*12 name of the SALT TRACKING data structure that will contain region volume and surface area vectors in addition to region identification pointers and other tracking information.

**TRKFIL** character\*12 name of the sequential binary tracking file used to store the tracks lengths.

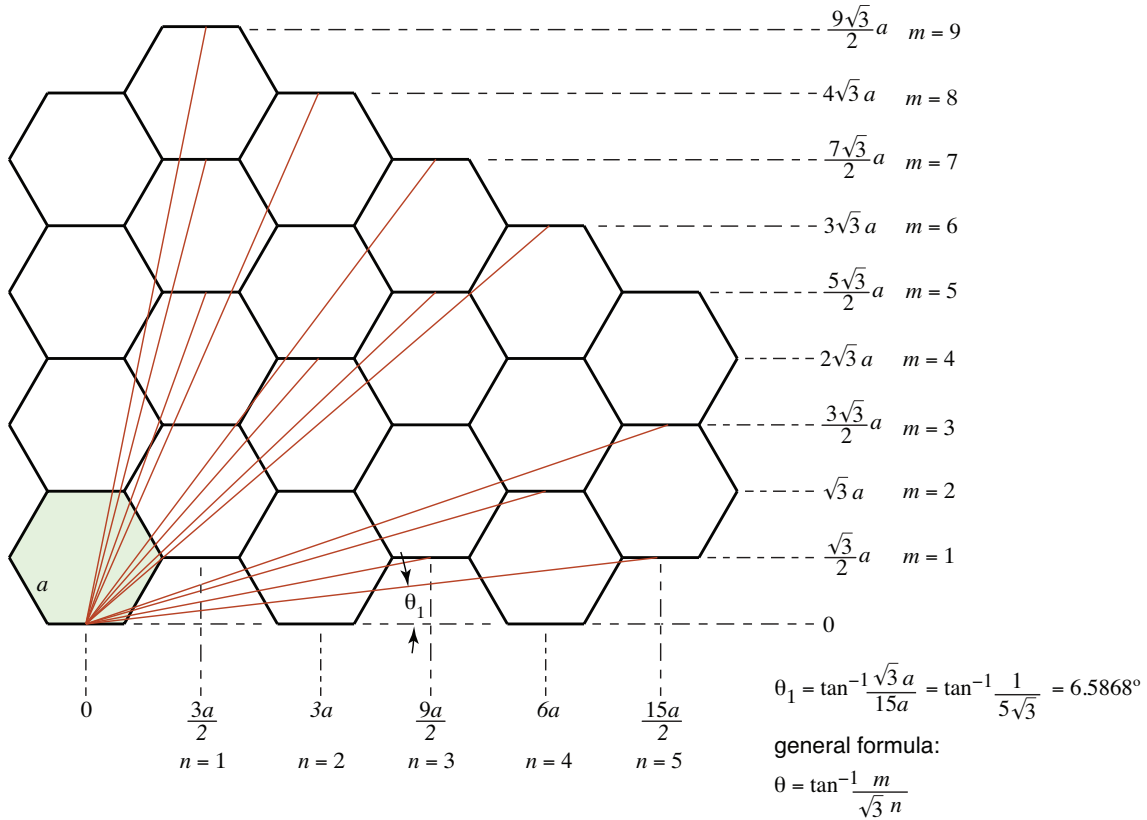

Figure 26: Cycling tracking over an hexagonal domain.

- SURFIL** **character\*12** name of the SALOMON–formatted sequential ASCII file used to store the surfacic elements of the geometry. This file may be build using the operator **G2S**: (see Section 5.1) or recovered from SALOME.
- GEONAM** **character\*12** name of the GEOMETRY data structure containing the double heterogeneity (Bihet) data.
- (desctrack)** structure describing the general tracking data (see Section 3.4)
- (descsalt)** structure describing the transport tracking data specific to SALT:.

All information for the modelization used can be found in 112. The SALT: specific tracking data in **(descsalt)** is defined as :

Table 122: Structure **(descsalt)**

```
[ ANIS nanis ]
[ { ONEG | ALLG } ]
[ [ QUAB iquab ] [ { SAPO | HEBE | SLSI [ frtm ] } ] ]
[ { PISO | PSPC [ CUT pcut ] } ]
[ { GAUS | CACA | CACB | LCMD | OPP1 | OGAU } [ nmU ] ]
{ TISO [ { EQW | GAUS | PNTN | SMS | LSN | QRN } ] nangl dens
  | TSPC [ { MEDI | EQW2 } ] nangl dens }
```

continued on next page

Structure (**descsalt**)

continued from last page

```
[ CORN pcorn ]
[ NOTR ]
[ NBSLIN nbslin ]
[ MERGMIX ]
[ LONG ]
;
```

where

|              |   |
|--------------|---|
| ANIS         | keyword to specify the order of scattering anisotropy.  |
| <i>nanis</i> | order of anisotropy in transport calculation. A default value of 1 represents isotropic (or transport-corrected) scattering while a value of 2 correspond to linearly anisotropic scattering.   |
| ONEG         | keyword to specify that the tracking is read before computing each group-dependent collision probability or algebraic collapsing matrix (default value if <i>TRKFIL</i> is set). The tracking file is read in each energy group if the method of characteristics (MOC) is used.   |
| ALLG         | keyword to specify that the tracking is read once and the collision probability or algebraic collapsing matrices are computed in many energy groups. The tracking file is read once if the method of characteristics (MOC) is used.   |
| QUAB         | keyword to specify the number of basis point for the numerical integration of each micro-structure in cases involving double heterogeneity (Bihet).   |
| <i>iquab</i> | the number of basis point for the numerical integration of the collision probabilities in the micro-volumes using the Gauss-Jacobi formula. The values permitted are: 1 to 20, 24, 28, 32 or 64. The default value is <i>iquab</i> = 5. If <i>iquab</i> is negative, its absolute value will be used in the She-Liu-Shi approach to determine the split level in the tracking used to compute the probability collisions. |
| SAPO         | use the Sanchez-Pomraning double-heterogeneity model. <sup>[51]</sup>   |
| HEBE         | use the Hebert double-heterogeneity model (default option). <sup>[52]</sup>   |
| SLSI         | use the She-Liu-Shi double-heterogeneity model without shadow effect. <sup>[53]</sup>   |
| <i>frtm</i>  | the minimum microstructure volume fraction used to compute the size of the equivalent cylinder in She-Liu-Shi approach. The default value is <i>frtm</i> = 0.05.  |
| PISO         | keyword to specify that a collision probability calculation with isotropic reflection boundary conditions is required. It is the default option if a TISO type integration is chosen. To obtain accurate transmission probabilities for the isotropic case it is recommended that the normalization options in the ASM: module be used.   |
| PSPC         | keyword to specify that a collision probability calculation with mirror like reflection or periodic boundary conditions is required; this is the default option if a TSPC type integration is chosen. This calculation is only possible if the file was initially constructed using the TSPC option.  |
| CUT          | keyword to specify the input of cutting parameters for the specular collision probability of characteristic integration.  |

|                   |  |
|-------------------|--|
| <i>pcut</i>       | real value representing the maximum error allowed on the exponential function used for specular collision probability calculations. Tracks will be cut at a length such that the error in the probabilities resulting from this reduced track will be of the order of <i>pcut</i> . By default, the tracks are extended to infinity and <i>pcut</i> = 0.0. If this option is used in an entirely reflected case, it is recommended to use the <code>NORM</code> command in the <code>ASM:</code> module. |
| <code>GAUS</code> | keyword to specify that Gauss-Legendre polar integration angles are to be selected for the polar quadrature when a prismatic tracking is considered. The conservation is ensured up to $P_{nm\mu-1}$ scattering.   |
| <code>CACA</code> | keyword to specify that CACTUS type equal weight polar integration angles are to be selected for the polar quadrature when a prismatic tracking is considered. <sup>[50]</sup> The conservation is ensured only for isotropic scattering.  |
| <code>CACB</code> | keyword to specify that CACTUS type uniformly distributed integration polar angles are to be selected for the polar quadrature when a prismatic tracking is considered. <sup>[50]</sup> The conservation is ensured only for isotropic scattering.   |
| <code>LCMD</code> | keyword to specify that optimized (McDaniel-type) polar integration angles are to be selected for the polar quadrature when a prismatic tracking is considered. <sup>[48]</sup> This is the default option. The conservation is ensured only for isotropic scattering.   |
| <code>OPP1</code> | keyword to specify that $P_1$ constrained optimized (McDaniel-type) polar integration angles are to be selected for the polar quadrature when a prismatic tracking is considered. <sup>[49]</sup> The conservation is ensured only for isotropic and linearly anisotropic scattering.  |
| <code>OGAU</code> | keyword to specify that Optimized Gauss polar integration angles are to be selected for the method of characteristics. <sup>[48, 49]</sup> The conservation is ensured up to $P_{nm\mu-1}$ scattering.   |
| <i>nmu</i>        | user-defined number of polar angles. By default, a value consistent with <i>nanagl</i> is computed by the code. For <code>LCMD</code> , <code>OPP1</code> , <code>OGAU</code> quadratures, <i>nmu</i> is limited to 2, 3 or 4.   |
| <code>TISO</code> | keyword to specify that isotropic tracking parameters will be supplied. This is the default tracking option for cluster geometries.  |
| <code>TSPC</code> | keyword to specify that specular tracking parameters will be supplied.   |
| <code>EQW</code>  | keyword to specify the use of equal weight quadrature. <sup>[43]</sup> The conservation is ensured up to $P_{nanagl/2}$ scattering.  |
| <code>GAUS</code> | (after <code>TISO</code> keyword) keyword to specify the use of the Gauss-Legendre quadrature. This option is valid only if an hexagonal geometry is considered.   |
| <code>PNTN</code> | keyword to specify that Legendre-Techbychev quadrature will be selected. <sup>[44]</sup> The conservation is ensured only for isotropic and linearly anisotropic scattering.   |
| <code>SMS</code>  | keyword to specify that Legendre-trapezoidal quadrature will be selected. <sup>[45]</sup> The conservation is ensured up to $P_{nanagl-1}$ scattering.   |
| <code>LSN</code>  | keyword to specify the use of the $\mu_1$ -optimized level-symmetric quadrature. The conservation is ensured up to $P_{nanagl/2}$ scattering.  |
| <code>QRN</code>  | keyword to specify the use of the quadrupole range (QR) quadrature. <sup>[34]</sup>  |
| <code>MEDI</code> | keyword to specify the use of a median angle quadrature in <code>TSPC</code> cases. For a rectangular Cartesian domain of size $X \times Y$ , the azimuthal angles in $(0, \pi/2)$ interval are obtained from formula  |

$$\phi_k = \tan^{-1} \frac{kY}{(2p+2-k)X}, \quad k = 1, 3, 5, \dots, 2p+1.$$



**EQW2** keyword to specify the use of a standard cyclic quadrature without angles  $\phi = 0$  and  $\phi = \pi/2$  in TSPC cases. For a rectangular Cartesian domain of size  $X \times Y$ , the azimuthal angles in  $(0, \pi/2)$  interval are obtained from formula

$$\phi_k = \tan^{-1} \frac{kY}{(p+2-k)X}, \quad k = 1, 2, 3, \dots, p+1.$$

This is the default option.

**nangl** angular quadrature parameter. For a 3-D EQW option, the choices are *nangl* = 2, 4, 8, 10, 12, 14 or 16. For a 3-D PNTN or SMS option, *nangl* is an even number smaller than 46.<sup>[42]</sup> For 2-D isotropic applications, any value of *nangl* may be used, equidistant angles will be selected.

For 2-D specular applications the input value must be of the form  $p+1$  where  $p$  is a prime number, as proposed in Ref. 28. In this case, the choice of *nangl* = 2, 6, 8, 12, 14, 18, 20, 24, or 30 are allowed. For hexagonal lattices, including equilateral triangular and lozenge geometry, the choice of *nangl* = 3, 6, 12 or 18 are allowed.

**dens** real value representing the density of the integration lines (in  $\text{cm}^{-1}$  for 2-D Cartesian cases. This choice of density along the plan perpendicular to each angle depends on the geometry of the cell to be analyzed. If there are zones of very small volume, a high line density is essential. This value will be readjusted by **SALT**:.

**CORN** keyword to specify the meaningful distance (cm) between a tracking line and a surfacic element.

**pcorn** meaningful distance (cm) between a tracking line and a surfacic element. By default, *pcorn* =  $1.0 \times 10^{-5}$  cm.

**NOTR** keyword to specify that the geometry will not be tracked. This is useful for 2-D geometries to generate a tracking data structure that can be used by the **PSP**: module (see Section 3.31). One can then verify visually if the geometry is adequate before the tracking process as such is undertaken.

**NBSLIN** keyword to set the maximum number of segments in a single tracking line.

**nbsl** integer value representing the maximum number of segments in a single tracking line. The default value is *nbsl* = 100000.

**MERGMIX** keyword to specify that all regions belonging to the same mixture will be merged together. This option should only be used as an attempt to reduce CPU costs in resonance self-shielding calculations.

**LONG** keyword to specify that a “long” tracking file will be generated. This option is required if the tracking file is to be used by the **TLM**: module (see Section 3.14).

## 6 THE UTILITY MODULES

DRAGON contains a number of utility modules used to perform tasks not related to reactor physics. These modules are also available to any code built around the Ganlib kernel and can be called from CLE-2000.<sup>[6,7]</sup>

### 6.1 The equality module

This module is used to duplicate a LCM object. The calling specifications are:

Table 123: Structure (**equality**)

```
NAME1 := [ NAME1 ] NAME2
[ :: [ EDIT iprint ] [ { OLD | SAP } ] [[ STEP { UP NOMDIR | AT index } ] ] ;
```

|               |   |
|---------------|---|
| <i>NAME1</i>  | <b>character*12</b> name of the output data structure. It can be a LCM object (either memory-resident or XSM-based), a sequential binary file, a sequential ASCII file or a HDF5 file. If <i>NAME1</i> is a LCM object and if it appears on both sides, it is erased and refilled with the contents of <i>NAME2</i> . |
| <i>NAME2</i>  | <b>character*12</b> name of the input data structure. It can be a LCM object (either memory-resident or XSM-based), a sequential binary file, a sequential ASCII file or a HDF5 file.   |
| EDIT          | keyword used to modify the print level <i>iprint</i> .  |
| <i>iprint</i> | index used to control the printing of this module. The amount of output produced by this tracking module will vary substantially depending on the print level specified.  |
| OLD           | keyword used to import/export a LHS sequential ASCII file in 1995 LCM specification. By default, the up-to-date specification is used.  |
| SAP           | keyword used to import/export a LHS sequential ASCII file in Saphyr LCM specification.  |
| STEP          | keyword used to move in the LCM object hierarchy of <i>NAME2</i> before making the copy.  |
| UP            | keyword used to move up towards a sub-directory of <i>NAME2</i> of the active directory.  |
| <i>NOMDIR</i> | copy the information located in the sub-directory named <i>NOMDIR</i> . If <i>NAME1</i> and <i>NAME2</i> are HDF5 files, <i>NOMDIR</i> is the name of a daughter group in <i>NAME2</i> .  |
| AT            | keyword used to move up towards a component in an heterogeneous list of <i>NAME2</i> .  |
| <i>index</i>  | copy the information located in the <i>index</i> -th component of the heterogeneous list.   |

If both the RHS and LHS are LCM objects (either memory-resident or XSM-based), a single copy is performed. A memory-resident LCM object can be created from an XSM file or an XSM file can be created from a memory-resident LCM object. If the LHS is a sequential file and the RHS is a LCM object, an export is performed. The export format is either binary or ASCII. If the LHS is a LCM object and the RHS is a sequential file, an import is performed. The case where both the LHS and the RHS are sequential files is not supported.

## 6.2 The UTL: module

The UTL: module is used to perform utility actions on a LCM object. The calling specifications are:

Table 124: Structure (UTL:)

```
[ NAME1 := ] UTL: [ NAME1 ] ::
[ EDIT iprint ]
[ DIR ] [ VAL ] [ NAN ] [ ERAS ]
[[ STEP { UP NOMDIR | AT index | DOWN | ROOT } [ NEW { DICT | LIST nsize } ] ] ]
[[ IMPR { BLOCK | index } { ileni | * } ] ]
[[ CREA { BLOCK | index } [ ilenc1 ] ilenc2 = { (valc(i),i=ilenc1,ilenc2) | (ivalc(i),i=ilenc1,ilenc2)
| (hvalc(i),i=ilenc1,ilenc2) | (dvalc(i),i=ilenc1,ilenc2) } ] ]
[[ DEL BLOCK ] ]
[[ { MULT | SADD } { BLOCK | index } flott ] ]
[[ { COPY | ADD } NOMREF NOMALT ] ]
[[ STAT { REL | ABS } NOMREF NOMALT [ >>errmax<< [ >>erravg<< ] ] ]
[ DUMP ] ;
```

|               |   |
|---------------|---|
| <i>NAME1</i>  | character*12 name of the LCM object that will be treated by the utility module.   |
| EDIT          | keyword used to modify the print level <i>iprint</i> . The default value is <i>iprint</i> = 1.  |
| <i>iprint</i> | index used to control the printing of this module. Set to 0 to reduce printing by the module.   |
| DIR           | keyword used to print the active directory content.   |
| VAL           | keyword used to validate the consistency of the connections in a LCM object.  |
| NAN           | keyword used to scan the LCM object for NaN values.   |
| ERAS          | keyword used to erase the contents of the LCM object.   |
| STEP          | keyword used to move in the LCM object hierarchy.   |
| UP            | keyword used to move up towards a sub-directory (associative table) of the active directory.  |
| <i>NOMDIR</i> | name of the sub-directory to which we wish to head.   |
| AT            | keyword used to move towards a component in an heterogeneous list of <i>NAME1</i> .   |
| <i>index</i>  | access the information located in the <i>index</i> -th component of the heterogeneous list.   |
| DOWN          | keyword to return to the sub-directory containing the active directory.   |
| ROOT          | keyword to return to the root directory of the LCM object.  |
| NEW           | keyword to specify that <i>NOMDIR</i> or <i>index</i> -th component is a new entry.   |
| DICT          | keyword to specify that <i>NOMDIR</i> or <i>index</i> -th component is an associative table.  |
| LIST          | keyword to specify that <i>NOMDIR</i> or <i>index</i> -th component is an heterogeneous list.   |
| <i>nsize</i>  | size of the heterogeneous list.   |
| IMPR          | keyword to print the complete contents or part of the record <i>BLOCK</i> or component <i>index</i> located on the current directory. |

|               |  |
|---------------|--|
| MULT          | keyword to multiply each element of a block or sub-directory in the active directory by a real constant. If <i>BLOCK</i> is a sub-directory, only floating point information contained in it is multiplied.                                    |
| SADD          | keyword to add a real constant to each element of a block or sub-directory in the active directory. If <i>BLOCK</i> is a sub-directory, only floating point information contained in it is added.  |
| CREA          | keyword used to create a block of information on the current directory.  |
| DEL           | keyword used to delete a block of information on the current directory.  |
| <i>BLOCK</i>  | name of the block or sub-directory selected.   |
| <i>ileni</i>  | maximum number of elements that the user wishes to print. A value of <i>ileni</i> =0 is permitted.   |
| *             | keyword, indicates that all the elements of a block will be printed. In a realistic case, the number of elements contained in a block may be rather large; this option must therefore be used with caution.                                    |
| <i>ilenc1</i> | index of the first element included in the block. Can only be set if block <i>BLOCK</i> already exists. By default, <i>ilenc1</i> = 1.   |
| <i>ilenc2</i> | index of the last element included in the block.   |
| =             | keyword, indicates that the input values will follow.  |
| <i>valc</i>   | real vector containing the information to be written in the record <i>BLOCK</i> .  |
| <i>ivalc</i>  | integer vector containing the information to be written in the record <i>BLOCK</i> .   |
| <i>hvalc</i>  | <b>character*4</b> array containing the information to be written in the record <i>BLOCK</i> .   |
| <i>dvalc</i>  | double precision array containing the information to be written in the record <i>BLOCK</i> .   |
| <i>floft</i>  | constant by which a block or sub-directory will be multiplied.   |
| COPY          | keyword used to copy an existing record or sub-directory onto a new record or sub-directory.   |
| ADD           | keyword used to add the contents of two records or two sub-directories. If <i>NOMREF</i> and <i>NOMALT</i> are two sub-directories, only the floating point information contained in them is added. The result is written into <i>NOMALT</i> . |
| <i>NOMREF</i> | name of the reference block.   |
| <i>NOMALT</i> | name of the block which is modified during the ADD operation, modified or created for the COPY operation and compared with the reference block for the STAT operation.   |
| STAT          | keyword used to compare the contents of two records.   |
| REL           | the relative differences are printed.  |
| ABS           | the absolute differences are printed.  |
| <i>errmax</i> | output variable for relative or absolute maximum error for the STAT operation.   |
| <i>erravg</i> | output variable for relative or absolute average error for the STAT operation.   |
| DUMP          | Dump the active directory of and its sub-directories to the printer.   |

### 6.3 The HUTL: module

A HDF5 file is a hierarchical structure made of groups (sub-structures) and datasets (arrays). The HUTL: module is used to perform utility actions on a HDF5 file.<sup>[122]</sup> The calling specifications are:

Table 125: Structure (HUTL:)

```
[ NAME1 := ] HUTL: [ NAME1 ] [ NAME2 ] ::
[[ DIR [ BLOCK ] ]]
[[ TEST BLOCK ]]
[[ INFO BLOCK ]]
[[ IMPR BLOCK ]]
[[ CREA BLOCK ]]
[[ CREA BLOCK [ [ ilenc1 ] ilenc2 ] = { (valc(i),i=ilenc1,ilenc2) | (ivalc(i),i=ilenc1,ilenc2)
| (hvalc(i),i=ilenc1,ilenc2) | (dvalc(i),i=ilenc1,ilenc2) } ]]
[[ DELE BLOCK ]]
[[ COPY BLOCK = BLOCK2 ]]
[[ GREP BLOCK [ ilenc1 ] >>value<< ] ;
```

|               |  |
|---------------|--|
| <i>NAME1</i>  | character*12 name of the HDF5 file that will be treated by the utility module.   |
| <i>NAME2</i>  | character*12 name of the source HDF5 file used with the action COPY.   |
| DIR           | keyword used to print a group table of content. If <i>BLOCK</i> is not set, the table of content of the root group is printed.   |
| TEST          | keyword used to test existence of a group.   |
| INFO          | keyword used to print information about a dataset.   |
| IMPR          | keyword to print the complete contents of a dataset.   |
| CREA          | keyword used to create a dataset. If both <i>ilenc1</i> and <i>ilenc2</i> are missing, a single value is readed. If only <i>CREA BLOCK</i> is defined, a group named <i>BLOCK</i> is created. Otherwise, a dataset is created. |
| <i>BLOCK</i>  | name of the group or dataset selected. The name of a group can include one or many path separators (character /) to list different hierarchical levels.  |
| <i>ilenc1</i> | index of the first element included in the block. Can only be set if block <i>BLOCK</i> already exists. By default, <i>ilenc1</i> = 1.   |
| <i>ilenc2</i> | index of the last element included in the block.   |
| =             | equality keyword, indicates that the input values will follow.   |
| <i>valc</i>   | real vector containing the information to be written in the record <i>BLOCK</i> .  |
| <i>ivalc</i>  | integer vector containing the information to be written in the record <i>BLOCK</i> .   |
| <i>hvalc</i>  | character*4 array containing the information to be written in the record <i>BLOCK</i> .  |
| <i>dvalc</i>  | double precision array containing the information to be written in the record <i>BLOCK</i> .   |
| DELE          | keyword used to delete group or dataset <i>BLOCK</i> .   |
| COPY          | keyword used to copy a group or a dataset in destination <i>BLOCK</i> of the HDF5 file named <i>NAME1</i> .  |

|               |  |
|---------------|--|
| =             | equality keyword, indicates that the input value will follow.  |
| <i>BLOCK2</i> | name of the source group or dataset selected in the HDF5 file named <i>NAME2</i> .   |
| GREP          | keyword used to recover a single component in a dataset of rank 1. If <i>ilenc1</i> is missing, the first value is recovered.  |
| <i>value</i>  | <b>character*12</b> CLE-2000 variable name in which the recovered value will be placed. This variable should be declared integer, real, character or double precision. |

#### 6.4 The DELETE: module

This module is used to delete one or many LCM objects. The calling specifications are:

Table 126: Structure (**DELETE:**)

```
[[ NAME1 ]] := DELETE: [[ NAME1 ]] [ :: EDIT iprint ] ;
```

*NAME1*            **character\*12** name of a LCM object.

**EDIT**            keyword used to modify the print level *iprint*.

*iprint*            index used to control the printing of this module. Set to 1 to print the name of the deleted objects.

The names of the LCM object should be present on both the LHS and the RHS. A LCM object named PARENT can be deleted using the following command:

```
PARENT := DELETE: PARENT ;
```

## 6.5 The BACKUP: module

This module is used to copy one or many LCM objects (memory-resident or XSM-based), along with all of its parent to a backup LCM object. The backup data structure can be stored on a single LCM object (either memory-resident or XSM-based), a sequential binary file or a sequential ASCII file. The calling specifications are:

Table 127: Structure (**BACKUP:**)

```

NAME1 := BACKUP: [ NAME1 ] [[ NAME2 ]] [ : :
[ EDIT iprint ]
[[ STEP { UP NOMDIR | AT index } ]] ;

```

|               |  |
|---------------|--|
| <i>NAME1</i>  | <b>character*12</b> name of LCM object used as a backup media.   |
| <i>NAME2</i>  | <b>character*12</b> name of LCM object to be transfer to the backup LCM object. This LCM object must be in a memory-resident or XSM-based format.                        |
| EDIT          | keyword used to modify the print level <i>iprint</i> .   |
| <i>iprint</i> | index used to control the printing of this module. The amount of output produced by this tracking module will vary substantially depending on the print level specified. |
| STEP          | keyword used to move in the LCM object hierarchy of <i>NAME2</i> before making the backup.   |
| UP            | keyword used to move up towards a sub-directory of <i>NAME2</i> of the active directory.   |
| <i>NOMDIR</i> | backup the information into the sub-directory named <i>NOMDIR</i> .  |
| AT            | keyword used to move up towards a component in an heterogeneous list of <i>NAME2</i> .   |
| <i>index</i>  | backup the information into the <i>index</i> -th component of the heterogeneous list.  |

If *NAME1* appears only on the LHS, it is created. If *NAME1* appears on both the LHS and the RHS, it is updated.



## 6.6 The RECOVER: module

This module is used to recover from a backup LCM object (see Section 6.5) one or many LCM objects (memory-resident or XSM-based). The calling specifications are:

Table 128: Structure (**RECOVER:**)

```
[[ NAME1 ]] := RECOVER: NAME2 [[ NAME1 ]] [ ::
[ EDIT iprint ]
[[ STEP { UP NOMDIR | AT index } ]] ] ;
```

|               |  |
|---------------|--|
| <i>NAME1</i>  | <b>character*12</b> name of the LCM objects that are to be recovered.  |
| <i>NAME2</i>  | <b>character*12</b> name of a backup LCM object.   |
| <b>EDIT</b>   | keyword used to modify the print level <i>iprint</i> .   |
| <i>iprint</i> | index used to control the printing of this module. The amount of output produced by this tracking module will vary substantially depending on the print level specified. |
| <b>STEP</b>   | keyword used to move in the LCM object hierarchy of <i>NAME2</i> before making the recover.  |
| <b>UP</b>     | keyword used to move up towards a sub-directory of <i>NAME2</i> of the active directory.   |
| <i>NOMDIR</i> | recover the information located in the sub-directory named <i>NOMDIR</i> .   |
| <b>AT</b>     | keyword used to move up towards a component in an heterogeneous list of <i>NAME2</i> .   |
| <i>index</i>  | recover the information located in the <i>index</i> -th component of the heterogeneous list.   |

If *NAME1* appears only on the LHS, it is created. If *NAME1* appears on both the LHS and the RHS, it is replaced by the information located on the backup media.

### 6.7 The ADD: module

This module is used to add the floating point information contained of the two LCM object located on the RHS. The result is stored in a third output LCM object. The calling specifications are:

Table 129: Structure (ADD:)

```
NAME1 := ADD: NAME2 NAME3 ;
```

*NAME1*            **character\*12** name of a LCM object which contains the final information.

*NAME2*            **character\*12** name of a LCM object which contains the first part of the initial information. One can use *NAME2=NAME1*.

*NAME3*            **character\*12** name of a LCM object which contains the second part of the initial information.

## 6.8 The MPX: module

This module is used to multiply the floating point information contained in a LCM object located on the RHS by a user-defined real number. The result is stored in a second output LCM object. The calling specifications are:

Table 130: Structure (MPX:)

```
NAME1 := MPX: NAME2 :: real ;
```

|              |   |
|--------------|---|
| <i>NAME1</i> | <b>character*12</b> name of a LCM object which contains the final information.  |
| <i>NAME2</i> | <b>character*12</b> name of a LCM object which contains the the initial information. One can use <i>NAME2=NAME1</i> . |
| <i>real</i>  | real number used as a multiplication factor.  |

## 6.9 The STAT: module

This module is used to compare the floating point information contained in two different LCM object. The calling specifications are:

Table 131: Structure (STAT:)

```
STAT: NAME1 NAME2 ;
```

*NAME1*            character\*12 name of the reference LCM object.

*NAME2*            character\*12 name of a compared LCM object.

## 6.10 The GREP: module

The GREP: module is used to extract a single value from a LCM object. The calling specifications are:

Table 132: Structure (**GREP:**)

```

GREP: NAME3 ::
[ EDIT iprint ]
[[ STEP { UP NOMDIR | AT index } ]]
[[ TYPE { BLOCK | index } >>itype<< ]]
[[ LENGTH { BLOCK | index } >>ilong<< ]]
[[ { GETVAL | MAXVAL | MINVAL | INDMAX | INDMIN | MEAN }
   { BLOCK | index } index1 [ { { index2 | * } [ index3 ] | NVAL { neval | * } } ]
   [[ >>value<< ]]
]] ;

```

|               |   |
|---------------|---|
| <i>NAME3</i>  | character*12 name of the LCM object from which extractions will be performed.   |
| EDIT          | keyword used to modify the print level <i>iprint</i> .  |
| <i>iprint</i> | index set to 1 to enable printing in this module. By default, <i>iprint</i> = 0.  |
| STEP          | keyword used to move in the LCM object hierarchy.   |
| UP            | keyword used to move up towards a sub-directory of the active directory.  |
| NOMDIR        | name of the sub-directory or heterogeneous list to which we wish to head.   |
| AT            | keyword used to move up towards a component in the heterogeneous list.  |
| <i>index</i>  | access the information located in the <i>index</i> -th component of the heterogeneous list.   |
| BLOCK         | name of the record which will be analyzed by the GREP: utility.   |
| <i>index</i>  | index of the record which will be analyzed by the GREP: utility.  |
| TYPE          | keyword used to get the LCM type of record <i>BLOCK</i> .   |
| <i>itype</i>  | type of block <i>BLOCK</i> or list component <i>index</i> (= 1: integer; = 2: real; = 3: character; = 4: double precision; = 5: logical; = 10: list; = 99: undefined).  |
| LENGTH        | keyword used to get the length of LCM record <i>BLOCK</i> .   |
| <i>ilong</i>  | length of record. If the record is made of characters ( <i>itype</i> = 3), then <i>ilong</i> is a character count.  |
| GETVAL        | keyword used to get values from an existing record. The receiving CLE-2000 variables are assumed to be of the same type as the picked values (all CLE-2000 types are supported).                                  |
| MAXVAL        | keyword used to get the maximum value of an existing record. The receiving CLE-2000 single variable is assumed to be of the same type as the picked maximum (valid for integer, real and double precision types). |
| MINVAL        | keyword used to get the minimum value of an existing record. The receiving CLE-2000 single variable is assumed to be of the same type as the picked minimum (valid for integer, real and double precision types). |

|               |   |
|---------------|---|
| INDMAX        | keyword used to get the index (position inside the block) of the maximum value of an existing record. The receiving CLE-2000 single variable is assumed of an integer type (valid for integer, real and double precision blocks). |
| INDMIN        | keyword used to get the index (position inside the block) of the minimum value of an existing record. The receiving CLE-2000 single variable is assumed of an integer type (valid for integer, real and double precision blocks). |
| MEAN          | keyword used to get the mean value of an existing record. The receiving CLE-2000 single variable is assumed to be of the same type as the computed mean (valid only for real and double precision types).                         |
| <i>index1</i> | the first element number in record <i>BLOCK</i> to be considered.   |
| <i>index2</i> | the last element in record <i>BLOCK</i> to be considered. If <i>index2</i> is absent only element <i>index1</i> will be considered.   |
| *             | the search will extend to the last element in the record <i>BLOCK</i> .   |
| <i>index3</i> | specifies the stride between values to be extracted between <i>index1</i> and <i>index2</i> . By default, a stride of 1 is assumed.   |
| NVAL          | keyword used to specify the number of elements to be extracted from the specified record.   |
| <i>neval</i>  | the number of elements to be extracted from the the specified record. If the record contains <b>character</b> information, elements <i>index1</i> to <i>index1+neval-1</i> are extracted.   |

The output parameters, denoted as  $\gg value \ll$ , are recovered as CLE-2000 variables in the module data located after the `::` keyword.

### 6.11 The MSTR module

This module is used to create user-defined structures. In particular, it can be used to store and retrieve user variables in a structure or copy specific records from different structures to a single one so that the user can have an easy access to the information he wants from a CLE-2000 procedure. The calling specifications are:

Table 133: Structure (MSTR:)

```
[ STRUCT := ] MSTR: [ STRUCT ] [[ EXTSTR ]] ::
[ EDIT iprint ]
[ TYPE type ]
[[ CD [ilcm:]path ]]
[[ GET nbelem [ indexfirst [ increment ] ] [ilcm:][path]recname [[ >> VAR_IN << ] ] ]
[[ PUT nbelem [ indexfirst [ increment ] ] [ilcm:][path]recname [[ value ] ] ]
[[ CP nbelem [ indexfirst [ increment ] ] [ilcm1:][path1]recname1 [ilcm2:] [path2]recname2 ] ]
;
```

|                   |   |
|-------------------|---|
| <i>STRUCT</i>     | <b>character*12</b> name of the user-defined LCM object in creation, modification or read-only mode depending on the requested actions.   |
| <i>EXTSTR</i>     | <b>character*12</b> name of existing LCM object from which information will be retrieved.   |
| EDIT              | keyword used to modify the print level <i>iprint</i> .  |
| <i>iprint</i>     | index used to control the printing of this module.  |
| TYPE              | keyword used to modify the structure signature.   |
| <i>type</i>       | string containing the user-defined signature, limited to 12 characters.   |
| CD                | keyword for introducing a UNIX-like command to change the active directory of the structures.   |
| <i>ilcm</i>       | integer defining the structure index according to its position in the LHS or RHS list of parameters. By default, equal to 1 (i.e. <i>STRUCT</i> is affected by the CD command).   |
| <i>path</i>       | string containing the UNIX-like path (relative or absolute) of the directory to access. Note that if the directory does not exist and that the structure is in creation/modification mode, it is created.   |
| <i>recname</i>    | string containing the record name. Note that if this record does not exist and that the structure is in creation/modification mode, it is created.<br><br>For example, <i>2:/dir/rec</i> refers to the record <i>rec</i> in the directory <i>dir</i> of the second structure in the calling specifications of the module. |
| GET               | keyword for introducing the action of retrieving variables from the structure.  |
| PUT               | keyword for introducing the action of storing variables in the structure.   |
| CP                | keyword for introducing the UNIX-like action of copying some elements from one record (defined by [ <i>ilcm1</i> :] <i>[path1][recname1]</i> ) to another ([ <i>ilcm2</i> :] [ <i>path2</i> ] <i>[recname2]</i> ).  |
| <i>nbelem</i>     | integer defining the number of elements to store/retrieve/copy.   |
| <i>indexfirst</i> | integer defining the index of the first element to store/retrieve/copy. By default, equal to 1.   |

|                  |   |
|------------------|---|
| <i>increment</i> | integer defining the stride in the record between the values to be stored/retrieved/copied. By default, equal to 1.   |
| <i>VAR_IN</i>    | <b>character*12</b> CLE-2000 variable name in which the extracted value will be placed. It is expected that the number of values extracted and the number (and types) of variables agree. |
| <i>value</i>     | value to be stored. The first one defines the record type and all the values should be of the same type.  |



## 6.12 The FIND0: module

The FIND0: module is used to find the root of a function using the Brent's method. This procedure assumes that the zero is bracketed in an interval given in the input using the two first points, and that the function used is continuous in this interval. The calling specifications are:

Table 134: Structure (FIND0:)

```
L0 := FIND0: [ L0 ] ::
{ [ DEBUG ] [ ITMAX itmax ] [ TOL tol ] POINT X x1 Y y1 POINT X x2 Y y2 | Y y3 }
>>lFlag<< >>rRoot<< ;
```

|              |  |
|--------------|--|
| <i>L0</i>    | character*12 names of the FIND0 LCM object (type L_0) that will contain all information necessary for the zero-finding procedure. If <i>L0</i> appears on both sides, it is updated; otherwise, it is created. |
| DEBUG        | keyword used to edit the content of most variables in FIND0; used only for debugging purposes.   |
| ITMAX        | keyword used to specify the maximum number of iterations that will be allowed for the zero-finding procedure. The procedure will abort if the number of iterations goes beyond this maximum value.             |
| <i>itmax</i> | the maximum number of iterations. Default value: 100.  |
| TOL          | keyword used to specify the tolerance on the zero to be found.   |
| <i>tol</i>   | tolerance. Default value: 1.E-5.   |
| POINT        | keyword used to specify that the next point will be given.   |
| X            | keyword used to specify that an abscissa will be given.  |
| Y            | keyword used to specify that an ordinate will be given.  |
| <i>x1</i>    | the first abscissa value.  |
| <i>y1</i>    | the first ordinate value.  |
| <i>x2</i>    | the second abscissa value.   |
| <i>y2</i>    | the second ordinate value.   |
| <i>y3</i>    | in the case we are in an update mode, only a new ordinate value is given.  |
| <i>lFlag</i> | CLE-2000 logical variable in writable mode. The value returned is <i>true</i> if the new guessed root is within <i>tol</i> , <i>false</i> otherwise.   |
| <i>rRoot</i> | CLE-2000 real variable in writable mode. The value returned is the last guess for the root.  |

Note that the zero-finding procedure has an initial mode where *NAME1*, *NAME2* and *NAME3* are created. In the initialization process, the two points specifying the interval must be given, and it is expected that  $y1 \times y2 < 0$ . In the updated mode, there is no need to put back the abscissa of the next point because it is expected to be the last real value that was generated by the procedure. This explains why you will only input *Y y3*.

The FIND0 specification is used to store intermediate values needed by the zero-finding procedure. There are no directories in this object, and it is created and updated only by the FIND0: module. To understand the content of the object, it is possible, using the labels given for every block, to refer to Brent's algorithm.<sup>[82]</sup>

### 6.13 The **ABORT:** module

This module is used to abort the overall calculation, calling the `XABORT()` subroutine from the `Ganlib`.

Table 135: Structure (**ABORT:**)

|                       |
|-----------------------|
| <code>ABORT: ;</code> |
|-----------------------|

#### 6.14 The END: module

This module is used to delete all the memory-resident LCM objects, to close all the remaining local files and to return from a procedure or to stop the run. The calling specifications are:

Table 136: Structure (END:)

|        |
|--------|
| END: ; |
|--------|

## 7 THE MPI MODULES

DRAGON contains two modules that enables MPI capabilities. These modules are also available to any code built around the Ganlib kernel and can be called from CLE-2000.<sup>[6,7]</sup> MPI capabilities must be activated using the `mpi=1` option of the makefiles.

### 7.1 The DRVMPI: module

This module is a utility module related to MPI. It is mostly used to know the rank of the node running the current script. The calling specifications are:

Table 137: Structure (**DRVMPI:**)

```
[ NAME := ] DRVMPI: :: [ EDIT iprint ] [ WORLD-SIZE >>ncpu<< ] [ MY-ID >>rank<< ]
[[ SETLOOP { B0 | B1 } len >>beg<< >>end<< ]]
[ ALLREDUCE { SUM | PROD | MAX | MIN } operand >>result<< ]
[ TIME >>dTime<< ] [ BARRIER ] ;
```

|               |  |
|---------------|--|
| <i>NAME</i>   | character*12 name of a dummy data structure to be possibly used as <i>NAME2</i> in the SNDMPI: module. It can be a linked list or an XSM file.                           |
| EDIT          | keyword used to modify the print level <i>iprint</i> .   |
| <i>iprint</i> | index used to control the printing of this module. The amount of output produced by this tracking module will vary substantially depending on the print level specified. |
| WORLD-SIZE    | keyword used to recover <i>ncpu</i> .  |
| <i>ncpu</i>   | total number of nodes in the MPI environment.  |
| MY-ID         | keyword used to recover <i>rank</i> .  |
| <i>rank</i>   | rank of the node that is running the script.   |
| SETLOOP       | keyword used to partition the set $\{0 \cdots len-1\}$ or $\{1 \cdots len\}$ equitably over the nodes. The result $\{beg \cdots end\}$ is different for each node.       |
| B0            | keyword used to set the initial position to 0.   |
| B1            | keyword used to set the initial position to 1.   |
| <i>len</i>    | set length.  |
| <i>beg</i>    | beginning of the set for the current script. Must be an integer variable.  |
| <i>end</i>    | end of the set for the current script. Must be an integer variable.  |
| ALLREDUCE     | keyword used to make a computation over all the <i>operand</i> and to store the result in <i>result</i> . Problems can be encountered in the 64-bits version.            |
| SUM           | keyword used to make ALLREDUCE perform a summation.  |
| PROD          | keyword used to make ALLREDUCE perform a multiplication.   |
| MAX           | keyword used to make ALLREDUCE find the maximum over all <i>operand</i> .  |
| MIN           | keyword used to make ALLREDUCE find the maximum over all <i>operand</i> .  |

|                |  |
|----------------|--|
| <i>operand</i> | operand in the ALLREDUCE calculation. Cannot be a string or a logical value.                 |
| <i>result</i>  | result of the ALLREDUCE calculation. Must be a variable of the same type as <i>operand</i> . |
| TIME           | keyword used to recover <i>dTime</i> .   |
| <i>dTime</i>   | time in seconds since an arbitrary time in the past. Must be a double precision variable.    |
| BARRIER        | keyword used to stop the calculation until every node has reach this barrier.                |

*NAME* is always empty. What matters is that *NAME* is no more only declared, it now exists after the call of DRVMPI: module.

The output parameters, denoted as >>*value*<<, are recovered as CLE-2000 variables in the module data located after the :: keyword.

## 7.2 The SNDMPI: module

This module is used to send or receive a linked list or an XSM file from one node to another one thanks to MPI. It is possible to send a linked list into an XSM file and vice versa. The module is blocked until the message is sent or received. The calling specifications are:

Table 138: Structure (SNDMPI:)

```
[ NAME1 := ] SNDMPI: [ NAME2 ] :: [ EDIT iprint ] FROM iFrom TO { iTo | ALL }
[ ITEM from >>to<< ] ;
```

|               |  |
|---------------|--|
| <i>NAME1</i>  | <b>character*12</b> name of the data structure that will be received. It can be a linked list or an XSM file.  |
| <i>NAME2</i>  | <b>character*12</b> name of the data structure that will be sent. It can be a linked list or an XSM file. Since on the RHS, it has to exist even for receiving scripts. In this case it is recommended to create an empty data structure <i>NAME2</i> by calling the DRVMPI: module. |
| EDIT          | keyword used to modify the print level <i>iprint</i> .   |
| <i>iprint</i> | index used to control the printing of this module. The amount of output produced by this tracking module will vary substantially depending on the print level specified.   |
| FROM          | keyword used to set <i>iFrom</i> .   |
| <i>iFrom</i>  | rank of the node from which <i>NAME2</i> has to be read.   |
| TO            | keyword used to set <i>iTo</i> .   |
| <i>iTo</i>    | rank of the node where <i>NAME1</i> has to be written.   |
| ALL           | keyword to make every node receive <i>NAME2</i> except the node <i>iFrom</i> .   |
| ITEM          | keyword used to send the value <i>from</i> to <i>to</i> either on <i>iTo</i> or ALL nodes. <i>NAME1</i> and <i>NAME2</i> are optional since they will be ignored.  |
| <i>from</i>   | value to send. Can be an integer, a real, a double or a logical.   |
| <i>to</i>     | variable used to receive <i>from</i> value. Must match <i>from</i> type.   |

## 8 EXAMPLES

We will now present a few examples of DRAGON input structures in such as to clarify and illustrate some of the options presented in Sections 3 and 6. These examples are *non-regression testcases* used to ensure that existing capabilities of Dragon are not lost with subsequent updates of the code. They make use of two assert procedures defined in CLE-2000 language, `assertS` and `assertV`, defined in Section 8.7. These procedures are generally not used in computational schemes.

### 8.1 Scattering cross sections

In DRAGON, the angular dependence of the scattering cross section is expressed in a Legendre series expansion of the form:

$$\Sigma_s(\Omega \cdot \Omega') = \Sigma_s(\mu) = \sum_{l=0}^L \left( \frac{(2l+1)}{4\pi} \right) \Sigma_{s,l} P_l(\mu).$$

Since the Legendre polynomials satisfy the following orthogonality conditions:

$$\int_{-1}^1 d\mu P_l(\mu) P_m(\mu) = \left( \frac{2\delta_{l,m}}{(2l+1)} \right),$$

we will have

$$\Sigma_{s,l} = \int_{-1}^1 d\mu \int_0^{2\pi} d\varphi \Sigma_s(\mu) P_l(\mu) = 2\pi \int_{-1}^1 d\mu \Sigma_s(\mu) P_l(\mu).$$

Let us now consider the following three-group ( $n\text{group}=3$ ) isotropic and linearly anisotropic scattering cross sections ( $L=n\text{aniso}=2$ ) given by:

| $l$ | $g$ | $\Sigma_{s,l}^{g \rightarrow 1}$ (cm <sup>-1</sup> ) | $\Sigma_{s,l}^{g \rightarrow 2}$ (cm <sup>-1</sup> ) | $\Sigma_{s,l}^{g \rightarrow 3}$ (cm <sup>-1</sup> ) |
|-----|-----|--|--|--|
|     | 1   | 0.90   | 0.80   | 0.00   |
| 0   | 2   | 0.00   | 0.70   | 0.60   |
|     | 3   | 0.00   | 0.30   | 0.40   |
|     | 1   | 0.09   | 0.05   | 0.08   |
| 1   | 2   | 0.00   | 0.07   | 0.06   |
|     | 3   | 0.03   | 0.00   | 0.04   |

In DRAGON this scattering cross section must be entered as

```
SCAT (* L=0 *) 1 1 (* 3->1 *)      (* 2->1 *)      (* 1->1 *) 0.90
          3 3 (* 3->2 *) 0.30 (* 2->2 *) 0.70 (* 1->2 *) 0.80
          2 3 (* 3->3 *) 0.40 (* 2->3 *) 0.60 (* 1->3 *)
SCAT (* L=1 *) 3 3 (* 3->1 *) 0.03 (* 2->1 *) 0.00 (* 1->1 *) 0.09
          2 2 (* 3->2 *)      (* 2->2 *) 0.07 (* 1->2 *) 0.05
          3 3 (* 3->3 *) 0.04 (* 2->3 *) 0.06 (* 1->3 *) 0.08
```

### 8.2 Geometries

In order to illustrate the use of the various geometries presented in Section 3.3, let us consider a few examples that can be treated by DRAGON.

- 1-D Slab geometry (see Figure 27):

This geometry can be analyzed using a SYBILT: tracking modules:

```
PLATE := GEO: :: CAR1D 6
X- VOID X+ ALBE 1.2
MESHX 0.0 0.1 0.3 0.5 0.6 0.8 1.0
SPLITX 2 2 2 1 2 1
MIX 1 2 3 4 5 6 ;
```



Figure 27: Slab geometry with mesh-splitting

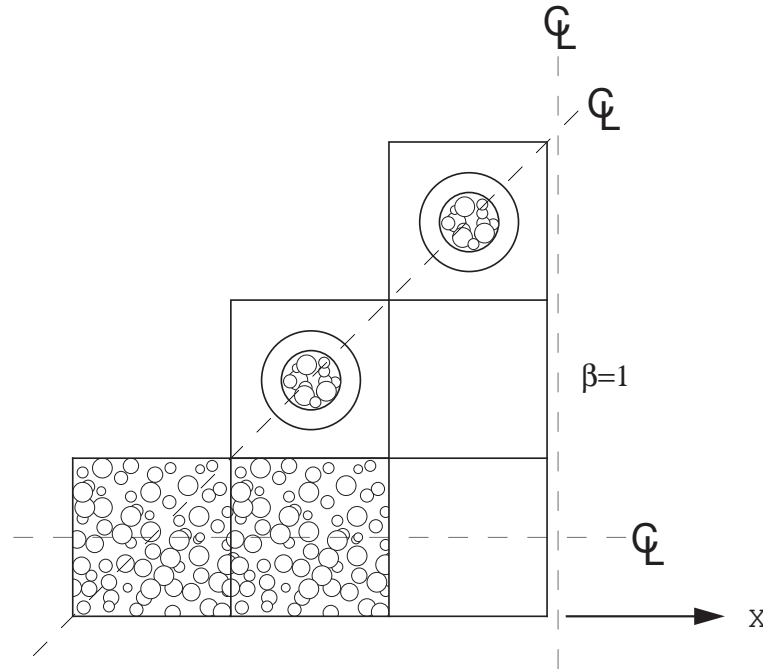

Figure 28: Two-dimensional Cartesian assembly containing micro-structures

- 2-D Cartesian geometry containing micro-structures (see figure Figure 28):

This geometry can be analyzed only using SYBILT: tracking modules:

```

CARNSG := GEO: :: CAR2D 3 3
X- DIAG X+ REFL Y- SYME Y+ DIAG
MIX  C1  C1  C2
      C3  C2
      C3

BIHET SPHE (*NG=*) 2 (* NMILG= *) 2 (* SPHERICAL MICRO-STRUCTURE *)
(* NS= *) 3 3
(* M-S-1 *) 0.0 0.1 0.2 0.3 (* M-S 2 *) 0.0 0.2 0.4 0.5
(* COMPOSITE MIXTURES *) 4 5
(* MIXTURES SURROUNDING M-S *) 1 1
(* COMPOSITE MIXTURE 4 FRACT *) 0.4 0.0
(* REAL MIXTURE CONTENT M-S-1 *) 3 1 3
(* COMPOSITE MIXTURE 5 FRACT *) 0.2 0.1
(* REAL MIXTURE CONTENT M-S-1 *) 1 2 1
(* REAL MIXTURE CONTENT M-S-2 *) 2 3 1
::: C1 := GEO: CAR2D 1 1 (* HOMOGENEOUS CELL WITH M-S *)
    MESHX 0.0 1.45 MESHY 0.0 1.45 MIX 4 ;
::: C2 := GEO: C1 (* HOMOGENEOUS CELL WITHOUT M-S *)
    MIX 1 ;
::: C3 := GEO: CARCEL 2 (* CELL WITH M-S TUBE *)

```

```

MESHX 0.0 1.45 MESHY 0.0 1.45
RADIUS 0.0 0.6 0.7
MIX 5 2 1 ;
;

```

- Cylindrical and Cartesian cluster geometry (see Figure 29):

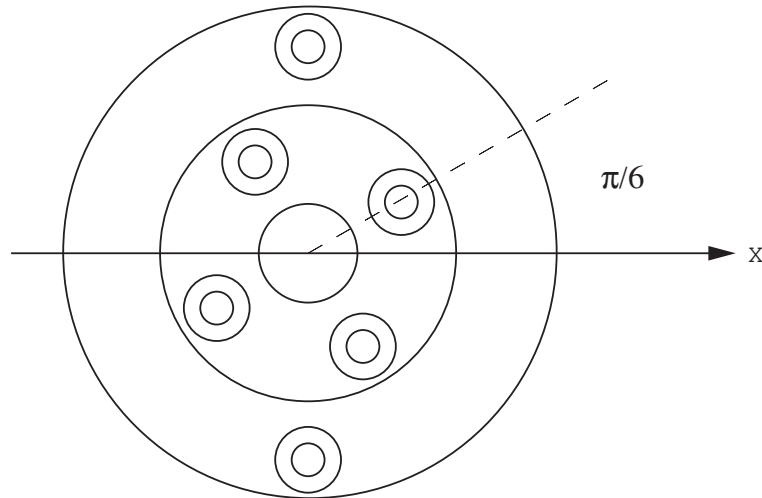

Figure 29: Cylindrical cluster geometry

The first two geometries, namely **ANNPIN** and **CARPIN** can be analyzed using a **EXCELT**: tracking modules since the pins in the clusters are all located between annular regions. For the last two geometries, **ANNSPIN** and **CARSPIN**, which are based on **ANNPIN** and **CARPIN** respectively, they only be treated by the **EXCELT**: tracking modules since the pins in the clusters intersect the annular regions defined by the **SPLITR** option. This later option which was selected to ensure a uniform thickness of 0.25 cm for each the annular region in the final geometries.

```

ANNPIN := GEO: :: TUBE 3
R+ REFL RADIUS 0.0 0.75 2.75 4.75
MIX 2 1 3
CLUSTER C1 C2
::: C1 := GEO: TUBE 2
MIX 2 4 RADIUS 0.0 0.3 0.6
NPIN 4 RPIN 1.75 APIN 0.523599 ;
::: C2 := GEO: C1
NPIN 2 RPIN 3.75 APIN 1.570796 ;
;
CARPIN := GEO: :: CARCEL 3
X- REFL X+ REFL Y- REFL Y+ REFL
MESHX 0.0 10.0 MESHY -5.0 5.0
RADIUS 0.0 0.75 2.75 4.75
MIX 2 1 3 3
CLUSTER C1 C2
::: C1 := GEO: TUBE 2
MIX 2 4 RADIUS 0.0 0.3 0.6
NPIN 4 RPIN 1.75 APIN 0.523599 ;
::: C2 := GEO: C1
NPIN 2 RPIN 3.75 APIN 1.570796 ;
;
ANNSPIN := GEO: ANNPIN ::

```



```

SPLITR  3 8 8 ;
CARSPIN := GEO: CARPIN ::
SPLITR  3 8 8 ;

```

Note that even if MESHX and MESHY differ in CARPIN, the annular regions and pins will still be localized with respect to the center of the cell located at  $(x, y) = (5.0, 0.0)$  cm.

- 2-D hexagonal geometry (see Figure 30):

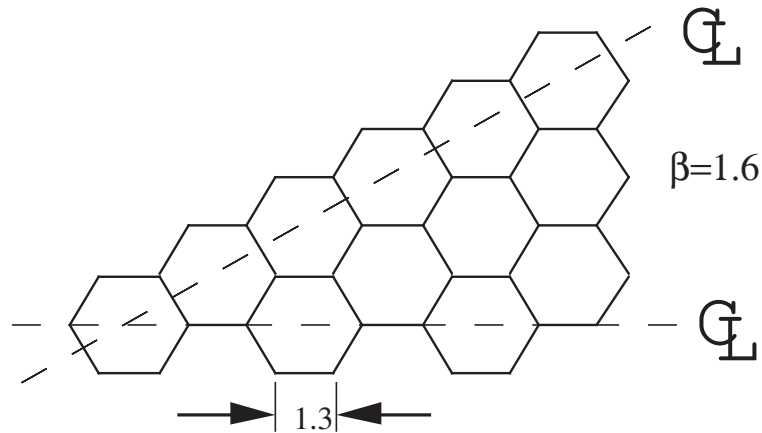

Figure 30: Two-dimensional hexagonal geometry

This geometry can be analyzed using the SYBILT: and EXCELT: tracking modules:

```

HEXAGON := GEO: :: HEX 12
HBC S30 ALBE 1.6
SIDE 1.3
MIX 1 1 1 2 2 2 3 3 3 4 5 6
;

```

- 3-D Cartesian supercell (see Figure 31):

This geometry can only be analyzed using the EXCELT: tracking modules:

```

SUPERCCELL := GEO: :: CAR3D 4 4 3
X- REFL  X+ REFL
Y- REFL  Y+ REFL
Z- REFL  Z+ REFL
MIX  A1 C1 D1 A3  A2 C2 D2 D2  A2 C2 C2 C2  A2 C2 C2 C2
      C3 C3 D3 A4  C4 C4 D4 D4  C4 C4 C4 C4  C4 C4 C4 C4
      C3 C3 D3 A4  C4 C4 D4 D4  C4 C4 C4 C4  C4 C4 C4 C4
::: C1 := GEO: CAR3D 1 1 1
MESHX 0.0 1.0 MESHY 0.0 1.5 MESHZ 0.0 2.0
MIX  1 ;
::: C2 := GEO: C1 MESHY 0.0 1.0 ;
::: C3 := GEO: C1 MESHZ 0.0 1.0 ;
::: C4 := GEO: C2 MESHZ 0.0 1.0 ;
::: D1 := GEO: C1 MIX 2 ;
::: D2 := GEO: C2 MIX 2 ;
::: D3 := GEO: C3 MIX 2 ;
::: D4 := GEO: C4 MIX 2 ;

```

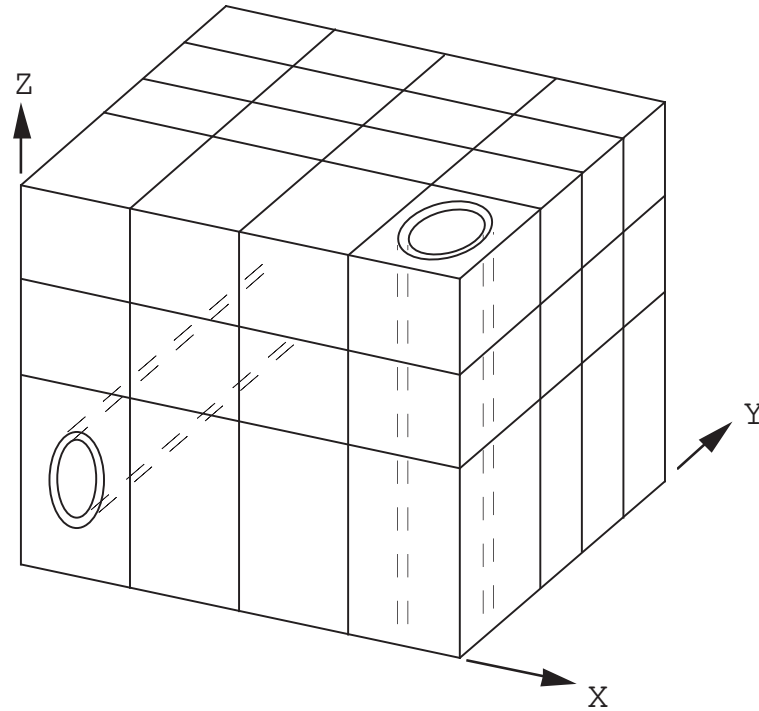

Figure 31: Three-dimensional Cartesian super-cell

```

::: A1 := GEO: CARCELY 2 1
  MESHX 0.0 1.0 MESHY 0.0 1.5 MESHZ 0.0 2.0
  RADIUS 0.0 0.4 0.45
  MIX      3 4 1 ;
::: A2 := GEO: A1 MESHY 0.0 1.0 ;
::: A3 := GEO: CARCELZ 2 1
  MESHX 0.0 1.0 MESHY 0.0 1.5 MESHZ 0.0 2.0
  RADIUS 0.0 0.3 0.35
  MIX      5 6 1 ;
::: A4 := GEO: A3 MESHZ 0.0 1.0 ;
;

```

- Multicell geometry in a 2-D hexagonal lattice (see Figure 32).

Here we are considering an infinite lattice having two types of cells such that

$$\begin{pmatrix} \text{pource}(1) \\ \text{pource}(2) \end{pmatrix} = \begin{pmatrix} 1/3 \\ 2/3 \end{pmatrix} \quad \text{and} \quad \begin{pmatrix} \text{procel}(1,1) & \text{procel}(1,2) \\ \text{procel}(2,1) & \text{procel}(2,2) \end{pmatrix} = \begin{pmatrix} 0 & 1 \\ 1/2 & 1/2 \end{pmatrix}$$

This lattice, can be represented either in a *do-it-yourself* type geometry (HEXDIY) or directly (HEXDIR):

```

HEXDIY := GEO: :: GROUP 2
  POURCE 0.3333333 0.6666667
  PROCEL 0.0      1.0
          0.5      0.5
  MIX     C1 C2
::: C1 := GEO: TUBE 1
  RADIUS 0.0 1.1822093 MIX 1 ;

```

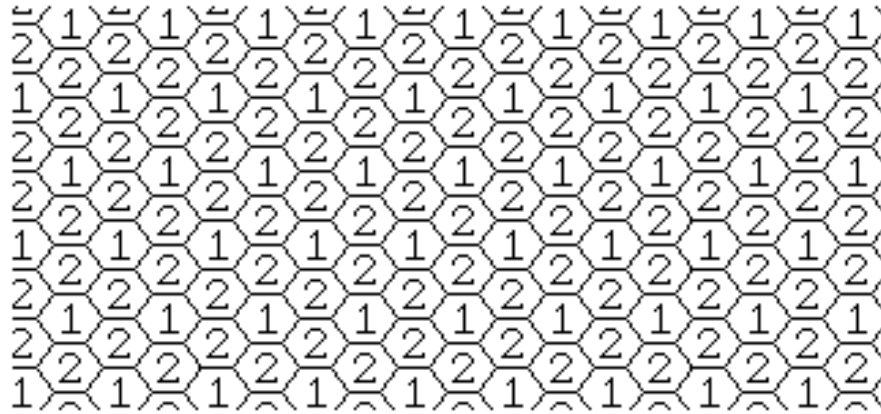

Figure 32: Hexagonal multicell lattice geometry

```

::: C2 := GEO: C1 MIX 2 ;
;
HEXDIR := GEO: :: HEX 2
HBC S30 SYME SIDE 1.3 MIX 1 2 ;

```

The first lattice can only be analyzed using the SYBILT: tracking module, while the second lattice can be analyzed using all the tracking modules of DRAGON.

### 8.3 MATXS7A microscopic cross-section examples

The test cases we will consider here use the LIB: module to specify that the cross sections will be taken from a MATXS7A 69 groups microscopic cross-sections library. We will assume that this library is located in file MATXS7A.

#### 8.3.1 (TCXA01) – The Mosteller benchmark.

The typical input data required to analyze this benchmark<sup>[97]</sup> with DRAGON is of the form:

Input data for test case: **TCXA01.x2m**

```
*-----
* TEST CASE TCXA01
* MOSTELLER BENCHMARK: 1-D ANNULAR CELL AND 2-D CARTESIAN CELL
* MATXS7A 69 GROUPS LIBRARY FILE MATXS7A (BASED ON ENDF-B/V)
*
* REF: R. Mosteller et al. Nucl. Sci. Eng. 107, 265 (1991)
*
*-----
* Define STRUCTURES and MODULES used
*-----
LINKED_LIST
  MOSTELA MOSTELC DISCR LIBRARY CP CALC OUT ;
SEQ_BINARY
  TRKSPC ;
MODULE
  LIB: GEO: SYBILT: EXCELT: SHI: ASM: FLU: EDI: DELETE: END: ;
PROCEDURE asserts ;
*-----
* Microscopic cross sections from file MATXS7A format MATXS
*-----
LIBRARY := LIB: ::
  NMIX 3 CTRA OLDW
  MIXS LIB: MATXS FIL: MATXS7A
  MIX 1 600.0
    O16      = O16      4.61309E-2   THER 42 FREE
    U235     = U235     1.66078E-4 1   THER 42 FREE
    U238     = U238     2.28994E-2 1   THER 42 FREE
  MIX 2 600.0
    Zr91     = ZRNAT    3.83243E-2   THER 42 FREE
  MIX 3 600.0
    H1H2O    = H1       4.42326E-2   THER 42 H2O
    O16H2O   = O16      2.21163E-2   THER 42 FREE
    BNat     = B10      2.03245E-6   THER 42 FREE
  ;
*-----
* Geometry MOSTELA : annular 3 region geometry
*                   MOSTELC : Cartesian 3 region geometry
*-----
MOSTELA := GEO: :: TUBE 3
  R+ REFL RADIUS 0.0 0.39306 0.45802 0.71206 SPLITR 2 1 1
  MIX 1 2 3 ;
MOSTELC := GEO: :: CARCEL 2
  X- REFL X+ REFL MESHX 0.0 1.26209
```

```

Y- REFL Y+ REFL MESHY 0.0 1.26209
RADIUS 0.0 0.39306 0.45802 SPLITR 2 1
MIX 1 2 3 ;
*-----
* Case 1 -- annular
* Self-Shielding calculation SYBIL
* Transport calculation      SYBIL
* Flux calculation for K no leakage
*-----
DISCR := SYBILT: MOSTELA ::
  TITLE 'TCWM01: MOSTELLER BENCHMARK (SYBIL / SYBIL)'
  MAXR 4 QUA1 5 ;
LIBRARY := SHI: LIBRARY DISCR :: EDIT 1 NOGC NOLJ
  GRMIN 5 GRMAX 27 ;
CP := ASM: LIBRARY DISCR ::
  PIJ ;
CALC := FLU: CP LIBRARY DISCR ::
  TYPE K ;
assertS CALC :: 'K-EFFECTIVE' 1 0.8214942 ;
OUT := EDI: LIBRARY DISCR CALC ::
  EDIT 4 MERG MIX 1 2 3 COND 27 69 SAVE ;
DISCR CP := DELETE: DISCR CP ;
*-----
* Case 2 -- Cartesian
* Self-Shielding calculation SYBIL
* Transport calculation      SYBIL
* Flux calculation for K no leakage
*-----
DISCR := SYBILT: MOSTELC ::
  TITLE 'TCWM01: MOSTELLER BENCHMARK (SYBIL / SYBIL)'
  MAXR 4 QUA1 5 QUA2 6 5 ;
LIBRARY := SHI: LIBRARY DISCR :: EDIT 1 NOGC NOLJ
  GRMIN 5 GRMAX 27 ;
CP := ASM: LIBRARY DISCR ::
  PIJ ;
CALC := FLU: CALC CP LIBRARY DISCR ::
  TYPE K ;
assertS CALC :: 'K-EFFECTIVE' 1 0.8212590 ;
OUT := EDI: OUT LIBRARY DISCR CALC ::
  EDIT 1 MERG MIX 1 2 3 COND 27 69 STAT ALL REFE 1 ;
DISCR CP := DELETE: DISCR CP ;
*-----
* Case 3 -- annular
* Self-Shielding calculation EXCEL-ISO
* Transport calculation      EXCEL-ISO
* Flux calculation for K no leakage
*-----
DISCR TRKSPC := EXCELT: MOSTELC ::
  TITLE 'TCWM01: MOSTELLER BENCHMARK (EXCELL)'
  MAXR 4 TRAK TISO 12 20.0 ;
LIBRARY := SHI: LIBRARY DISCR TRKSPC :: EDIT 1 NOGC NOLJ
  GRMIN 5 GRMAX 27 ;
CP := ASM: LIBRARY DISCR TRKSPC ::
  PIJ ;
CALC := FLU: CALC CP LIBRARY DISCR ::

```

```

TYPE K ;
assertS CALC :: 'K-EFFECTIVE' 1 0.8220187 ;
OUT := EDI: OUT LIBRARY DISCR CALC ::
  EDIT 1 MERG MIX 1 2 3 COND 27 69 STAT ALL REFE 1 ;
DISCR TRKSPC CP := DELETE: DISCR TRKSPC CP ;
*-----
* Case 4 -- Cartesian
* Self-Shielding calculation EXCEL-SPC
* Transport calculation      EXCEL-SPC
* Flux calculation for K no leakage
*-----
DISCR TRKSPC := EXCEL: MOSTELC ::
  TITLE 'TCWM01: MOSTELLER BENCHMARK (EXCELL)'
  MAXR 4 TRAK TSPC 12 20.0 ;
LIBRARY := SHI: LIBRARY DISCR TRKSPC :: EDIT 1 NOGC NOLJ
  GRMIN 5 GRMAX 27 ;
CP := ASM: LIBRARY DISCR TRKSPC ::
  PIJ ;
CALC := FLU: CALC CP LIBRARY DISCR ::
  TYPE K ;
assertS CALC :: 'K-EFFECTIVE' 1 0.8238403 ;
OUT := EDI: OUT LIBRARY DISCR CALC ::
  EDIT 1 MERG MIX 1 2 3 COND 27 69 STAT ALL REFE 1 ;
DISCR TRKSPC CP := DELETE: DISCR TRKSPC CP ;
ECHO "test TCXA01 completed" ;
END: ;

```

The input deck begins with declarations for the linked lists and the interface files and the various modules used for this DRAGON execution. Any word not declared is considered as a keyword.

The LIB: module is used to interpolate the microscopic cross sections in absolute temperature and dilution and to produce group-ordered macroscopic cross sections. We use the MATXS format 69 groups microscopic cross section library named 'MATXS7A'.<sup>[73]</sup> Each mixture at a given absolute temperature (in Kelvin) is defined in terms of MATXS isotope names (U235, U238, O16, etc.). In this case, the number density (in  $10^{24}$  particules per cubic centimeter) for each isotope is provided. Resonant region indices and the type of thermal scattering approximation used with the 42 thermal groups (free gas or H<sub>2</sub>O molecular model) is also specified. Only MATXS type libraries require the thermalization model to be set.

The GEO: module is used to define the geometry. Here two types of geometry are considered, MOSTELA a 1-D annular geometry and MOSTELC a 2-D Cartesian geometry. These geometries are defined before knowing the type of discretization or numerical treatment that will follow. For MOSTELA the first line indicates that the geometry has circular boundaries and that it contains three concentric annular subregions. The boundary conditions (reflection), the annular radii and the mixture index corresponding to each region of the cell are given successively. For MOSTELC the first line indicates that this geometry has 2-D Cartesian boundaries containing three subregions, two of which are annular. The boundary conditions (reflection on each side), the annular radii, the external side widths and the mixture index corresponding to each region of the cell are given successively.

Four cases are then considered. First we will analyse the annular geometry using the SYBILT: module for flux calculation. The DISCR and ddtracking structures are thereby generated. The SHI: module uses microscopic cross section data contained in the LIBRARY and tracking information contained in 'DISCR' and 'TRACKS' in order to compute the actual dilution of each resonant isotope (U235 and U238) and to perform a new interpolation in the MATXS file. Dilutions are only computed for the energy groups with resonance data present on the library; the other groups are assumed to stay at infinite dilution.

For the second case we will analyse the Cartesian geometry using the again the SYBILT: tracking module for self shielding calculations and the SYBILT: module for flux calculation. The DISCR and TRACKING structures are thereby generated.

Four cases are then considered. First we will analyse the annular geometry using the SYBILT: tracking module allows the geometry named 'MOSTEL' to be discretized by the full CP tracking algorithm. A new tracking file (sequential binary) is created and named 'TRACKS', together with a TRACKING1 structure named 'DISCR'. A periodic tracking (with 12 angles and 20.0 tracks per cm) is considered here.

The ASM: module uses macroscopic cross section data contained in the embedded MACROLIB of 'LIBRARY' and tracking information contained in 'DISCR' and 'TRACKS' in order to compute the reduced and scattering modified collision probability matrices for each of the 69 energy groups. We have not used the important capability of DRAGON to use a different tracking to perform self-shielding and flux calculations.

The FLU: module uses macroscopic cross section data contained in 'LIBRARY' (recovered from the dependency tree) and CPs contained in 'CP' in order to compute the neutron flux for each of the 69 energy groups. The transport equation is solved for the effective multiplication factor without buckling or leakage model.

Next, the EDI: module performs spatial homogenization (the cross sections are smeared over the complete cell) and coarse energy group condensation. The first coarse energy group contains the micro-groups 1 to 27; the second coarse energy group contains the remaining micro-groups.

## 8.4 Macroscopic cross sections examples

The sample test cases we will consider here use the `MAC:` module to enter macroscopic cross sections directly into DRAGON. They are numbered successively from (TCM01) to (TCM08).

### 8.4.1 (TCM01) – Annular region

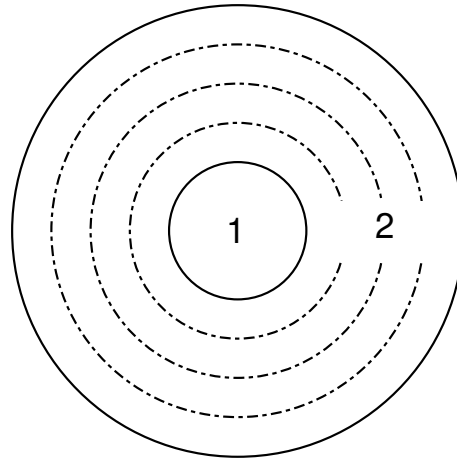

Figure 33: Geometry for test case (TCM01) for an annular cell with macroscopic cross sections.

This sample input is used to analyze the annular cell presented in Figure 33. It uses two-groups macroscopic cross sections provided directly by the user. One type of solution is provided here, one with a complete collision probability calculation (`SYBILT:`). Note that for the second flux calculation the initial flux distribution is taken from the existing `FLUXUNK` structure which already contains the flux distribution from the `SYBILT:` calculation.

Input data for test case: **TCM01.x2m**

```
*-----
* TEST CASE TCM01
* MACROSCOPIC CROSS SECTIONS
* FISSION SOURCE PROBLEM
* 1-D ANNULAR CELL
*
* REF: none
*
*-----
* Define STRUCTURES and MODULES used
*-----
LINKED_LIST
  MACRO ANGEO TRACK SYS FLUX EDITION ;
SEQ_ASCII
  res ;
MODULE
  GEO: SYBILT: MAC: ASM: FLU: EDI: DELETE: END: ;
PROCEDURE assertS ;
*-----
* Macroscopic XS
*-----
```



```

MACRO := MAC: ::
  NGRO 2 NMIX 2 NIFI 1
  READ INPUT
  MIX 1  TOTAL 0.222222 0.833333
    SCAT  1 1  0.19222      2 2 0.75333 0.02
    NUSIGF 0.0 0.135 CHI 1.0 0.0
  MIX 2  TOTAL 0.166667 1.111111
    SCAT  2 2  0.00015 0.126667 2 2 1.10111 0.04
  ;
*-----
*  Geometry :  ANGIO - Annular 2 regions
*-----
ANGIO := GEO: :: TUBE 2
  R+ REFL
  RADIUS 0.0 0.19653 1.0
  MIX      1      2
  SPLITR   1      4  ;
*-----
*  Tracking : SYBILT
*  Solution : PIJ
*  1- KEFF WITHOUT BUCKLING
*  2- BUCKLING WITH KEFF=1
*  3- LEAKAGE WITH KEFF=1
*-----
TRACK := SYBILT: ANGIO ::
  TITLE 'TCM01: ANNULAR GEOMETRY WITH MACROSCOPIC XS (SYBIL)'
  EDIT 1 MAXR 5 QUA1 5 ;
SYS := ASM: MACRO TRACK ;
FLUX := FLU:      SYS MACRO TRACK ::
  TYPE K ;
assertS FLUX :: 'K-INFINITY' 1 4.048651E-01 ;
EDITION := EDI: MACRO TRACK FLUX ::
  EDIT 3 SAVE ;
FLUX := FLU: FLUX SYS MACRO TRACK ::
  TYPE B BO PNL ;
assertS FLUX :: 'K-INFINITY' 1 4.060840E-01 ;
EDITION := EDI: EDITION MACRO TRACK FLUX ::
  EDIT 3 SAVE ;
FLUX := FLU: FLUX SYS MACRO TRACK ::
  TYPE L BO PNL ;
assertS FLUX :: 'K-INFINITY' 1 4.060870E-01 ;
EDITION := EDI: EDITION MACRO TRACK FLUX ::
  EDIT 3 SAVE ;
FLUX SYS TRACK := DELETE: FLUX SYS TRACK ;
ECHO "test TCM01 completed" ;
END: ;
QUIT "LIST" .

```

#### 8.4.2 (TCM02) – The Stankovski test case.

This test case represents a one group calculation of a  $7 \times 7$  PWR assembly. The reaction rates obtained from DRAGON can be compared with those obtained using the MARSYAS code.<sup>[27,28,98]</sup> The corresponding geometry is shown in Figure 34 where the cell numbers generated by DRAGON are shown.

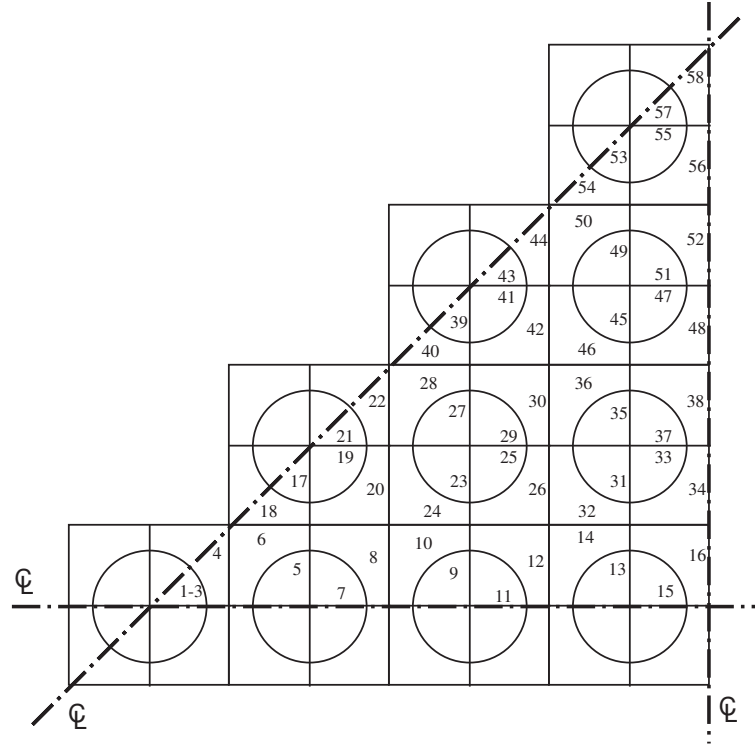

Figure 34: Geometry for test case (TCM02).

Input data for test case: **TCM02.x2m**

```

*-----
* TEST CASE TCM02
* MACROSCOPIC CROSS SECTIONS
* FIXED SOURCE PROBLEM
* FOR 1/8 7X7 PWR ASSEMBLY
*
* REF: Z. Stankovski, Nucl. Sci. Eng. 92, 255 (1986)
*       R. Roy et al. Advances in Mathematics, Computation
*       and Reactor Physics, April 28 - May 2 1991, Pittsburgh
*
*-----
* Define STRUCTURES and MODULES used
*-----
LINKED_LIST
  PWR TRACK MACRO SYS FLUX EDITION ;
SEQ_BINARY
  PWRTRK ;
MODULE
  GEO: EXCELT: MAC: ASM: FLU: EDI: END: DELETE: ;
PROCEDURE assertV ;
*-----
* Macroscopic XS
*-----
MACRO := MAC: ::
  NGRO 1 NMIX 3
  READ INPUT

```

```

MIX 1 TOTAL 1.250 SCAT 1 1 1.242 FIXE 1.000
MIX 2 TOTAL 0.625 SCAT 1 1 0.355 FIXE 0.000
MIX 3 TOTAL 14.000 SCAT 1 1 0.000 FIXE 0.000
;
*-----
* Geometry : PWR - Cartesian 4X4
* Tracking : EXCELT
*-----
PWR := GEO: :: CAR2D 4 4
  X- DIAG X+ REFL Y- SYME Y+ DIAG
  CELL  P F F F
        F F F
        F F
        F
  ::: F := GEO: CARCEL 1
    RADIUS 0.000 0.450 MIX 2 1
    MESHX -0.625 0.625 SPLITX 2
    MESHY -0.625 0.625 SPLITY 2
  ;
  ::: P := GEO: F
    MIX 3 1 SPLITR 3
  ;
;
TRACK PWRTRK := EXCELT: PWR ::
  TITLE 'TCM02: STANKOVSKI PWR ASSEMBLY'
  MAXR 58 CUT 1.E-4 TRAK TSPC 12 8.0
;
*-----
* Solution : FIXED SOURCE PROBLEM
* Editing : Absorption rates taken from STANKOVSKI
* cell 1 = 0.83799 0.00689 cell 2 = 0.73979 0.03571
* cell 3 = 0.82218 0.03991 cell 4 = 0.85166 0.04104
* cell 5 = 0.78722 0.03824 cell 6 = 1.67049 0.08092
* cell 7 = 1.71199 0.08252 cell 8 = 0.85350 0.04120
* cell 9 = 1.72122 0.08328 cell 10= 0.86023 0.04174
* NOTE: There is a factor 4.0 with the EDI: results of DRAGON
*-----
SYS := ASM: MACRO TRACK PWRTRK ;
FLUX := FLU:      SYS MACRO TRACK ::
  TYPE S ;
assertV FLUX :: 'FLUX' (*GROUP*) 1 (*REGION*) 10 5.300486 ;
EDITION := EDI: MACRO TRACK FLUX ::
  EDIT 2 SAVE
  MERGE REGION 1 1 1 2 3 4 3 4 5 6 5 6 7 8 7 8
  9 10 9 10 9 10 11 12 11 12 11 12 11 12 13 14 13 14 13 14 13 14
  15 16 15 16 15 16 17 18 17 18 17 18 17 18
  19 20 19 20 19 20
;
PWRTRK := DELETE: PWRTRK ;
ECHO "test TCM02 completed" ;
END: ;
QUIT "LIST" .

```

## 8.4.3 (TCM03) – Watanabe and Maynard problem with a void region.

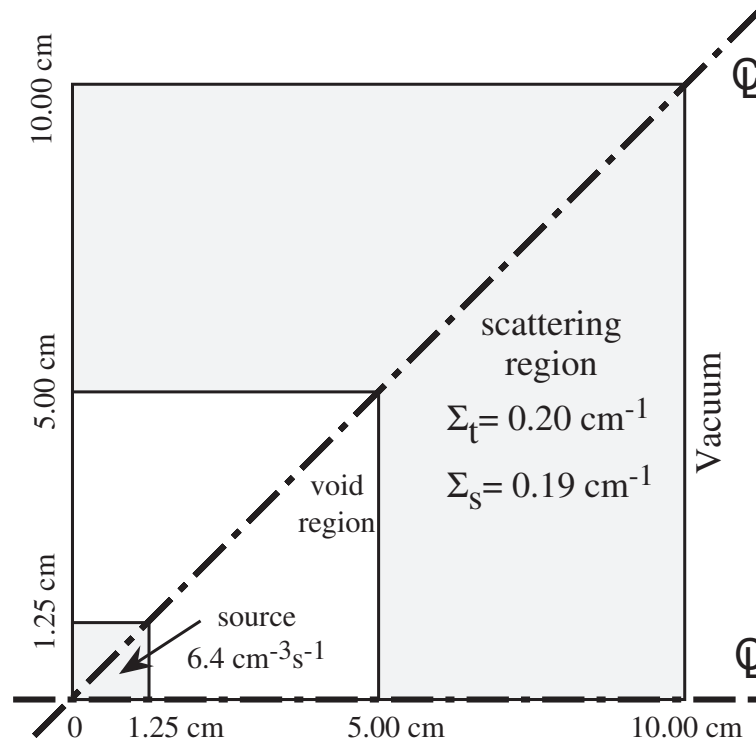

Figure 35: Geometry for test case (TCM03).

This test case is a one group problem with a central void region. This benchmark was first proposed by Watanabe and Maynard. Akroyd and Riyait used it to analyze the performance of various codes.<sup>[27,28,99]</sup>

Input data for test case: **TCM03.x2m**

```

*-----
* TEST CASE TCM03
* MACROSCOPIC CROSS SECTIONS
* FIXED SOURCE PROBLEM
* CARTESIAN 3 X 3 ASSEMBLY
*
* REF: Akroyd and Riyait, Ann. Nucl. Energy 16, 1 (1989)
*       R. Roy et al. Advances in Mathematics, Computation
*       and Reactor Physics, April 28 - May 2 1991, Pittsburgh
*       R. Roy, Ann. Nucl. Energy 18, 511 (1991)
*
*-----
* Define STRUCTURES and MODULES used
*-----
LINKED_LIST
  WATA WAT08 WAT16 WAT24 TRACK MACRO SYS FLUX EDITION ;
SEQ_BINARY
  WATATRK ;
MODULE
  GEO: EXCELT: MAC: ASM: FLU: EDI: DELETE: END: ;

```

```

PROCEDURE assertV ;
*-----
* Macroscopic XS
*-----
MACRO := MAC: ::
  NGRO 1 NMIX 3
  READ INPUT
  MIX 1 TOTAL 0.2 SCAT 1 1 0.19 FIXE 6.4
  MIX 2 TOTAL 0.2 SCAT 1 1 0.19
  MIX 3 TOTAL 0.0 SCAT 1 1 0.00
  ;
*-----
* Geometry : WATA - 3 X 3 REGIONS
*             WAT08 - 8 X 8 REGIONS
*             WAT16 - 16 X 16 REGIONS
*             WAT24 - 24 X 24 REGIONS
* Tracking : EXCELT
*-----
WATA := GEO: :: CAR2D 3 3
  X- DIAG X+ VOID Y- REFL Y+ DIAG
  MESHX 0.00 1.25 5.00 10.00 MESHY 0.00 1.25 5.00 10.00
  MIX 1 3 2
      3 2
      2
  ;
WAT08 := GEO: WATA ::
  SPLITX 1 3 4 SPLITY 1 3 4
  ;
WAT16 := GEO: WATA ::
  SPLITX 2 6 8 SPLITY 2 6 8
  ;
WAT24 := GEO: WATA ::
  SPLITX 3 9 12 SPLITY 3 9 12
  ;
*-----
* Tracking : EXCELT - WAT08
* Solution : FIXED SOURCE PROBLEM
* Editing : 1- UPPER QUADRANT FLUX
*           2- FLUX AT X=5.625CM
*-----
TRACK WATATRK := EXCELT: WAT08 ::
  TITLE 'TCM03: WATANABE-MAYNARD 8X8 '
  MAXR 300 CUT 1.E-4 TRAK TSPC 12 4.0
  ;
SYS := ASM: MACRO TRACK WATATRK ::
  SKIP
  ;
FLUX := FLU: SYS MACRO TRACK ::
  TYPE S THER 1.E-6 100 EXTE 1.E-6 100
  ;
assertV FLUX :: 'FLUX' (*GROUP*) 1 (*REGION*) 10 4.037368 ;
EDITION := EDI: MACRO TRACK FLUX ::
  EDIT 2 SAVE
  MERGE REGION
  0 0 0 0 0 0 0 0

```

```

    0 0 0 0 0 0 0
      0 0 0 0 0 0
        0 0 0 0 0
          1 2 3 4
            5 6 7
              8 9
                10
;
EDITION := EDI: EDITION MACRO TRACK FLUX ::
  EDIT 2 SAVE
  MERGE REGION
    0 0 0 0 1 0 0 0
      0 0 0 2 0 0 0
        0 0 3 0 0 0
          0 4 0 0 0
            5 6 7 8
              0 0 0
                0 0
                  0
;
TRACK WATATRK SYS FLUX := DELETE: TRACK WATATRK SYS FLUX ;
*-----
* Tracking : EXCELT - WAT16
* Solution : FIXED SOURCE PROBLEM
* Editing : 1- UPPER QUADRANT FLUX
*           2- FLUX AT X=5.625CM
*-----
TRACK WATATRK := EXCELT: WAT16 ::
  TITLE 'TCM03: WATANABE-MAYNARD 16X16 '
  MAXR 300 CUT 1.E-4 TRAK TSPC 12 8.0
;
SYS := ASM: MACRO TRACK WATATRK ::
  SKIP
;
FLUX := FLU: SYS MACRO TRACK ::
  TYPE S THER 1.E-6 100 EXTE 1.E-6 100
;
assertV FLUX :: 'FLUX' (*GROUP*) 1 (*REGION*) 10 2.986663 ;
EDITION := EDI: EDITION MACRO TRACK FLUX ::
  EDIT 2 SAVE
  MERGE REGION
    0 0 0 0 0 0 0 0 0 0 0 0 0 0 0 0
      0 0 0 0 0 0 0 0 0 0 0 0 0 0 0 0
        0 0 0 0 0 0 0 0 0 0 0 0 0 0 0 0
          0 0 0 0 0 0 0 0 0 0 0 0 0 0 0 0
            0 0 0 0 0 0 0 0 0 0 0 0 0 0 0 0
              0 0 0 0 0 0 0 0 0 0 0 0 0 0 0 0
                0 0 0 0 0 0 0 0 0 0 0 0 0 0 0 0
                  0 0 0 0 0 0 0 0 0 0 0 0 0 0 0 0
                    1 1 2 2 3 3 4 4
                      1 2 2 3 3 4 4
                        5 5 6 6 7 7
                          5 6 6 7 7
                            8 8 9 9
                              8 9 9

```

```

                                10 10
                                10
;
EDITION := EDI: EDITION MACRO TRACK FLUX ::
  EDIT 2 SAVE
  MERGE REGION
  0 0 0 0 0 0 0 0 1 1 0 0 0 0 0 0
    0 0 0 0 0 0 0 2 2 0 0 0 0 0 0
      0 0 0 0 0 0 3 3 0 0 0 0 0 0
        0 0 0 0 0 4 4 0 0 0 0 0 0
          0 0 0 0 5 5 0 0 0 0 0 0
            0 0 0 6 6 0 0 0 0 0 0
              0 0 7 7 0 0 0 0 0 0
                0 8 8 0 0 0 0 0 0

                                9 10 12 13 14 15 16 17
                                11 12 13 14 15 16 17
                                    0 0 0 0 0 0
                                        0 0 0 0 0
                                            0 0 0 0
                                                0 0 0
                                                    0 0
                                                        0
;
TRACK WATATRK SYS FLUX := DELETE: TRACK WATATRK SYS FLUX ;
*-----
* Tracking : EXCELT - WAT24
* Solution : FIXED SOURCE PROBLEM
* Editing  : 1- UPPER QUADRANT FLUX
*           2- FLUX AT X=5.625CM
*-----
TRACK WATATRK := EXCELT: WAT24 ::
  TITLE 'TCM03: WATANABE-MAYNARD 24X24 '
  MAXR 300 CUT 1.E-4 TRAK TSPC 12 12.0
;
SYS := ASM: MACRO TRACK WATATRK ::
  SKIP
;
FLUX := FLU: SYS MACRO TRACK ::
  TYPE S THER 1.E-6 100 EXTE 1.E-6 100
;
assertV FLUX :: 'FLUX' (*GROUP*) 1 (*REGION*) 10 3.947211 ;
EDITION := EDI: EDITION MACRO TRACK FLUX ::
  EDIT 2 SAVE
  MERGE REGION
  0 0 0 0 0 0 0 0 0 0 0 0 0 0 0 0 0 0 0 0 0 0
    0 0 0 0 0 0 0 0 0 0 0 0 0 0 0 0 0 0 0 0 0 0
      0 0 0 0 0 0 0 0 0 0 0 0 0 0 0 0 0 0 0 0 0 0
        0 0 0 0 0 0 0 0 0 0 0 0 0 0 0 0 0 0 0 0 0 0
          0 0 0 0 0 0 0 0 0 0 0 0 0 0 0 0 0 0 0 0 0 0
            0 0 0 0 0 0 0 0 0 0 0 0 0 0 0 0 0 0 0 0 0 0
              0 0 0 0 0 0 0 0 0 0 0 0 0 0 0 0 0 0 0 0 0 0
                0 0 0 0 0 0 0 0 0 0 0 0 0 0 0 0 0 0 0 0 0 0
                  0 0 0 0 0 0 0 0 0 0 0 0 0 0 0 0 0 0 0 0 0 0
                    0 0 0 0 0 0 0 0 0 0 0 0 0 0 0 0 0 0 0 0 0 0

```

```

0 0 0 0 0 0 0 0 0 0 0 0 0 0 0
  0 0 0 0 0 0 0 0 0 0 0 0 0 0
    0 0 0 0 0 0 0 0 0 0 0 0 0
      1 0 0 2 0 0 3 0 0 4 0
        0 0 0 0 0 0 0 0 0 0
          0 0 0 0 0 0 0 0
            5 0 0 6 0 0 7 0
              0 0 0 0 0 0
                0 0 0 0 0
                  8 0 0 9 0
                    0 0 0 0
                      0 0 0
                        10 0
                          0
;
EDITION := EDI: EDITION MACRO TRACK FLUX ::
EDIT 2 SAVE
MERGE REGION
0 0 0 0 0 0 0 0 0 0 0 0 0 1 0 0 0 0 0 0 0 0 0 0 0 0
  0 0 0 0 0 0 0 0 0 0 0 0 0 2 0 0 0 0 0 0 0 0 0 0 0 0
    0 0 0 0 0 0 0 0 0 0 0 0 0 3 0 0 0 0 0 0 0 0 0 0 0 0
      0 0 0 0 0 0 0 0 0 0 0 0 0 4 0 0 0 0 0 0 0 0 0 0 0 0
        0 0 0 0 0 0 0 0 0 0 0 0 0 5 0 0 0 0 0 0 0 0 0 0 0 0
          0 0 0 0 0 0 0 0 0 0 0 0 0 6 0 0 0 0 0 0 0 0 0 0 0 0
            0 0 0 0 0 0 0 0 0 0 0 0 0 7 0 0 0 0 0 0 0 0 0 0 0 0
              0 0 0 0 0 0 0 0 0 0 0 0 0 8 0 0 0 0 0 0 0 0 0 0 0 0
                0 0 0 0 0 0 0 0 0 0 0 0 0 9 0 0 0 0 0 0 0 0 0 0 0 0
                  0 0 0 0 0 10 0 0 0 0 0 0 0 0 0 0 0 0 0 0 0 0 0 0 0
                    0 0 0 0 0 11 0 0 0 0 0 0 0 0 0 0 0 0 0 0 0 0 0 0
                      0 0 0 0 0 12 0 0 0 0 0 0 0 0 0 0 0 0 0 0 0 0 0
                        0 0 0 0 0 13 0 0 0 0 0 0 0 0 0 0 0 0 0 0 0 0 0
                          14 15 16 17 18 19 20 21 22 23 24
                            0 0 0 0 0 0 0 0 0 0 0 0
                              0 0 0 0 0 0 0 0 0 0
                                0 0 0 0 0 0 0 0
                                  0 0 0 0 0 0 0 0
                                    0 0 0 0 0 0 0
                                      0 0 0 0 0
                                        0 0 0
                                          0 0
                                            0
;
WATATRK := DELETE: WATATRK ;
ECHO "test TCM03 completed" ;
END: ;
QUIT "LIST" .

```

8.4.4 (TCM04) – Adjuster rod in a CANDU type supercell.

This test case represents a two group calculation of incremental cross sections resulting from the insertion of stainless steel adjuster rods in a CANDU-6 supercell.



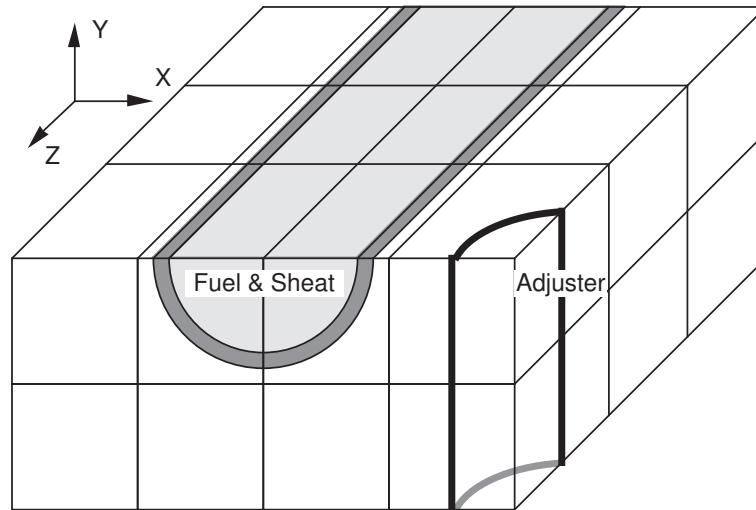

Figure 36: Geometry of the CANDU-6 supercell with stainless steel rods.

Input data for test case: **TCM04.x2m**

```

*-----
* TEST CASE TCM04
* MACROSCOPIC CROSS SECTIONS
* FISSION SOURCE PROBLEM
* CANDU 3-D ADJUSTER ROD 1/8-ASSEMBLY
*
* REF: none
*-----
* Define STRUCTURES and MODULES used
*-----
LINKED_LIST
  BC TRACK MACRO SYS FLUX EDITION
  TRACK2      SYS2 FLUX2 EDITION2  ;
SEQ_BINARY
  BCTRK ;
MODULE
  GEO: EXCELT: MAC: ASM: FLU: EDI: DELETE: END: ;
PROCEDURE asserts ;
*-----
* Macroscopic XS
*-----
MACRO := MAC: ::
  NGRO 2 NMIX 4 NIFI 1
  READ INPUT
  MIX 1 TOTAL      3.22798014E-1 3.81341100E-1
        NUSIGF     5.46564534E-3 7.17375278E-2
        CHI        1.0           0.0
        SCAT 2 2   3.13575147E-4 3.11233580E-1
                2 2   3.24143648E-1 2.19577667E-3
  MIX 2 TOTAL      1.49818063E-1 1.59792125E-1
        SCAT 2 2   7.40572286E-5 1.47693634E-1
                2 2   1.57371104E-1 1.30506000E-3
  MIX 3 TOTAL      2.60458171E-1 3.77224326E-1

```

```

          SCAT 2 2  5.98954648E-5 2.49342978E-1
              2 2  3.77127469E-1 1.11155845E-2
MIX 4  TOTAL      2.60458171E-1 3.77224326E-1
          SCAT 2 2  5.98954648E-5 2.49342978E-1
              2 2  3.77127469E-1 1.11155845E-2

```

```

;
*-----
* Geometry : BC - 3D Cartesian assembly with annular regions
* Tracking : 1) EXCELT ALLG
*           2) EXCELT XCLL
*-----
BC := GEO: :: CAR3D 3 2 2
X- REFL X+ SYME Y- REFL Y+ SYME Z- REFL Z+ SYME
CELL M  MX MX MX FXY MXY  M  MX BX MX FXY BXY
TURN A  A  A  F  A  A    A  A  A  F  A  A
::: M := GEO: CAR3D 1 1 1
  MESHX 0.0 7.14375 MESHY 0.0 7.14375 MESHZ -8.25500 +8.25500
  SPLITZ 2 MIX 3
;
::: MX := GEO: M
  MESHX -7.14375 +7.14375 SPLITX 2
;
::: MXY := GEO: MX
  MESHY -7.14375 +7.14375 SPLITY 2
;
::: BX := GEO: CARCELY 2 1
  MESHX -7.14375 +7.14375 SPLITX 2
  MESHY 0.0 +7.14375
  MESHZ -8.25500 +8.25500 SPLITZ 2
  RADIUS 0.0 3.5100 3.8100
  MIX 3 4 3
;
::: BXY := GEO: BX
  MESHY -7.14375 +7.14375 SPLITY 2
;
::: FXY := GEO: CARCELZ 2 1
  MESHX -7.14375 +7.14375 SPLITX 2
  MESHY -7.14375 +7.14375 SPLITY 2
  MESHZ -8.25500 +8.25500 SPLITZ 2
  RADIUS 0.0 5.16890 6.58750
  MIX 1 2 3
;
;
TRACK BCTRK := EXCELT: BC ::
  TITLE 'TCM04: TWO GROUPS CANDU 3-D ADJUSTER ROD ASSEMBLY '
  MAXR 40 ALLG TRAK TISO 4 2.5
;
SYS := ASM: MACRO TRACK BCTRK ;

TRACK2 := EXCELT: BC ::
  TITLE 'TCM04: TWO GROUPS CANDU 3-D ADJUSTER ROD ASSEMBLY '
  MAXR 40 XCLL TRAK TISO 4 2.5
;
SYS2 := ASM: MACRO TRACK2 ;
*-----

```

```

* Solution : K-EFFECTIVE
* Editing : Compute reference reaction rates
*-----
FLUX := FLU: SYS MACRO TRACK ::
  TYPE K
  ;
assertS FLUX :: 'K-EFFECTIVE' 1 1.103927 ;
EDITION := EDI: MACRO TRACK FLUX ::
  EDIT 3 UPS  MERG COMP SAVE ON 'NOROD'
  ;
FLUX := FLU: FLUX SYS2 MACRO TRACK2 ::
  TYPE K
  ;
assertS FLUX :: 'K-EFFECTIVE' 1 1.103921 ;
EDITION := EDI: EDITION MACRO TRACK2 FLUX ::
  EDIT 3 UPS  MERG COMP STAT ALL REFE 'NOROD'
  ;
EDITION2 := EDI: MACRO TRACK2 FLUX ::
  EDIT 3 UPS  MERG COMP SAVE ON 'NOROD'
  ;
SYS SYS2 := DELETE: SYS SYS2 ;
*-----
* Modify Macrolib for adjuster rod material
* Solution : K-EFFECTIVE
* Editing : Compute Delta-Sigma
*-----
MACRO := MAC: MACRO ::
  READ INPUT
  MIX 4  TOTAL      6.96358740E-1 1.12379551E+0
          SCAT 2 2   2.55611958E-4 6.77430272E-1
          2 2       9.55488145E-1 3.16311372E-3
  ;
SYS := ASM: MACRO TRACK BCTRK ;
SYS2 := ASM: MACRO TRACK2 ;
FLUX := FLU: FLUX SYS MACRO TRACK ::
  TYPE K
  ;
assertS FLUX :: 'K-EFFECTIVE' 1 1.016438 ;
EDITION := EDI: EDITION MACRO TRACK FLUX ::
  EDIT 3 UPS  MERG COMP STAT DELS REFE 'NOROD'
  ;
FLUX := FLU: FLUX SYS2 MACRO TRACK2 ::
  TYPE K
  ;
assertS FLUX :: 'K-EFFECTIVE' 1 1.016686 ;
EDITION2 := EDI: EDITION2 MACRO TRACK2 FLUX ::
  EDIT 3 UPS  MERG COMP STAT DELS REFE 'NOROD'
  ;
BCTRK := DELETE: BCTRK ;
ECHO "test TCM04 completed" ;
END: ;
QUIT "LIST" .

```

## 8.4.5 (TCM05) – Comparison of leakage models

This test presents various homogeneous and heterogeneous leakage models on a simple cell.

Input data for test case: **TCM05.x2m**

```

*-----
* TEST CASE TCM05
* MACROSCOPIC CROSS SECTIONS
* FISSION SOURCE PROBLEM
* 2-D CARTESIAN/ANNULAR CELL
* Validating leakage options
* TYPE K B L FOR MOSTELC (NO VOID)
* TYPE K B L FOR MOSTELCV (MOSTELC WITH VOID)
*
*-----
* Define STRUCTURES and MODULES used
*-----
LINKED_LIST
  MOSTELC MOSTELCV TRACK MACRO SYS FLUX EDITION ;
SEQ_BINARY
  TRKSPC ;
MODULE
  GEO: EXCELT: MAC: ASM: FLU: EDI: DELETE: END: ;
PROCEDURE assertS ;
*-----
* Macroscopic XS
*-----
MACRO := MAC: ::
  NGRO 2 ANIS 2 NMIX 2 NIFI 1
  READ INPUT
  MIX 1  TOTAL          0.222222  0.833333
  SCAT   1 1  0.19222 2 2  0.75333  0.02
         1 1  0.1    2 2  0.5      0.01
  NUSIGF      0.0      0.135  CHI          1.0      0.0
  MIX 2  TOTAL          0.166667  1.111111
  SCAT   2 2  0.00015  0.126667 2 2  1.10111  0.04
         2 2  0.0001   0.1    2 2  0.5      0.01
  ;
*-----
* Geometry : MOSTELC - Cartesian 2D cell without void region
*           MOSTELCV - Cartesian 2D cell with void region
*-----
MOSTELC := GEO: :: CARCEL 2
  X- REFL X+ REFL  Y- REFL Y+ REFL
  MESHX 0.0 1.26209  MESHY 0.0 1.26209
  RADIUS 0.0 0.39306 0.45802 SPLITR 2 1
  MIX 1 2 2 ;
MOSTELCV := GEO: MOSTELC ::
  MIX 1 0 2 ;
*-----
* Tracking : EXCELT - MOSTELC
*           ANIS 2 for adequate dimensions in PIJK
* Solution : TYPE K, B or L
* Leakage  : B1 PNL, B1 HETE

```

```

*-----
TRACK TRKSPC := EXCELT: MOSTELC ::
  TITLE 'TCM05: ANNULAR GEOMETRY WITH MACROSCOPIC XS'
  MAXR 5 ANIS 2 TRAK TISO 12 20.0 ;
SYS := ASM: MACRO TRACK TRKSPC ::
  PIJK ;
FLUX := FLU:          SYS MACRO TRACK ::
  TYPE K ;
assertS FLUX :: 'K-INFINITY' 1 1.199508 ;
EDITION := EDI: MACRO TRACK FLUX ::
  EDIT 2 SAVE ;
FLUX := FLU: FLUX SYS MACRO TRACK ::
  TYPE K B1 PNL BUCK 1.51429E-03 ;
assertS FLUX :: 'K-INFINITY' 1 1.195777 ;
EDITION := EDI: EDITION MACRO TRACK FLUX ::
  EDIT 2 SAVE ;
FLUX := FLU: FLUX SYS MACRO TRACK ::
  TYPE B B1 PNL KEFF 1.199538 ;
assertS FLUX :: 'K-INFINITY' 1 1.199508 ;
EDITION := EDI: EDITION MACRO TRACK FLUX ::
  EDIT 2 SAVE ;
FLUX := FLU: FLUX SYS MACRO TRACK ::
  TYPE B B1 PNL ;
assertS FLUX :: 'K-INFINITY' 1 1.195775 ;
EDITION := EDI: EDITION MACRO TRACK FLUX ::
  EDIT 2 SAVE ;
FLUX := FLU: FLUX SYS MACRO TRACK ::
  TYPE L B1 PNL ;
assertS FLUX :: 'K-INFINITY' 1 1.195778 ;
EDITION := EDI: EDITION MACRO TRACK FLUX ::
  EDIT 2 SAVE ;
FLUX := DELETE: FLUX ;
FLUX := FLU:          SYS MACRO TRACK ::
  TYPE K B1 HETE BUCK 1.50298E-03 ;
assertS FLUX :: 'K-INFINITY' 1 1.195597 ;
EDITION := EDI: EDITION MACRO TRACK FLUX ::
  EDIT 2 SAVE ;
FLUX := FLU: FLUX SYS MACRO TRACK ::
  TYPE B B1 HETE KEFF 1.199538 ;
assertS FLUX :: 'K-INFINITY' 1 1.199507 ;
EDITION := EDI: EDITION MACRO TRACK FLUX ::
  EDIT 2 SAVE ;
FLUX := FLU: FLUX SYS MACRO TRACK ::
  TYPE B B1 HETE R BUCK Z 5.00993E-04 ;
assertS FLUX :: 'K-INFINITY' 1 1.195596 ;
EDITION := EDI: EDITION MACRO TRACK FLUX ::
  EDIT 2 SAVE ;
FLUX := FLU: FLUX SYS MACRO TRACK ::
  TYPE B B1 HETE Z BUCK R 1.001986E-03 ;
assertS FLUX :: 'K-INFINITY' 1 1.195598 ;
EDITION := EDI: EDITION MACRO TRACK FLUX ::
  EDIT 2 SAVE ;
FLUX := FLU: FLUX SYS MACRO TRACK ::
  TYPE B B1 HETE ;
assertS FLUX :: 'K-INFINITY' 1 1.195598 ;

```

```

EDITION := EDI: EDITION MACRO TRACK FLUX ::
  EDIT 2 SAVE ;
FLUX := FLU: FLUX SYS MACRO TRACK ::
  TYPE L B1 HETE R BUCK Z 5.00993E-04 ;
assertS FLUX :: 'K-INFINITY' 1 1.195598 ;
EDITION := EDI: EDITION MACRO TRACK FLUX ::
  EDIT 2 SAVE ;
FLUX := FLU: FLUX SYS MACRO TRACK ::
  TYPE L B1 HETE Z BUCK R 1.001986E-03 ;
assertS FLUX :: 'K-INFINITY' 1 1.195598 ;
EDITION := EDI: EDITION MACRO TRACK FLUX ::
  EDIT 2 SAVE ;
FLUX := FLU: FLUX SYS MACRO TRACK ::
  TYPE L B1 HETE ;
assertS FLUX :: 'K-INFINITY' 1 1.195598 ;
EDITION := EDI: EDITION MACRO TRACK FLUX ::
  EDIT 2 SAVE ;
FLUX SYS := DELETE: FLUX SYS ;
*-----
* Tracking : EXCELT - MOSTELCV only update TRACK TRKSPC files
*           since only change is in one material
* Solution : TYPE K, B or L
* Leakage  : B1 PNL, B1 HETE
*-----
TRACK TRKSPC := EXCELT: TRACK TRKSPC MOSTELCV ::
  TITLE 'TCM05: ANNULAR GEOMETRY WITH MACROSCOPIC XS (VOID)' ;
SYS := ASM: MACRO TRACK TRKSPC ::
  PIJK ;
FLUX := FLU:          SYS MACRO TRACK ::
  TYPE K ;
assertS FLUX :: 'K-INFINITY' 1 1.227979 ;
EDITION := EDI: EDITION MACRO TRACK FLUX ::
  EDIT 2 SAVE ;
FLUX := FLU: FLUX SYS MACRO TRACK ::
  TYPE K B1 PNL BUCK 1.40181E-03 ;
assertS FLUX :: 'K-INFINITY' 1 1.223228 ;
EDITION := EDI: EDITION MACRO TRACK FLUX ::
  EDIT 2 SAVE ;
FLUX := FLU: FLUX SYS MACRO TRACK ::
  TYPE B B1 PNL KEFF 1.228007 ;
assertS FLUX :: 'K-INFINITY' 1 1.227979 ;
EDITION := EDI: EDITION MACRO TRACK FLUX ::
  EDIT 2 SAVE ;
FLUX := FLU: FLUX SYS MACRO TRACK ::
  TYPE B B1 PNL ;
assertS FLUX :: 'K-INFINITY' 1 1.223224 ;
EDITION := EDI: EDITION MACRO TRACK FLUX ::
  EDIT 2 SAVE ;
FLUX := FLU: FLUX SYS MACRO TRACK ::
  TYPE L B1 PNL ;
assertS FLUX :: 'K-INFINITY' 1 1.223230 ;
EDITION := EDI: EDITION MACRO TRACK FLUX ::
  EDIT 2 SAVE ;
FLUX := DELETE: FLUX ;
FLUX := FLU:          SYS MACRO TRACK ::

```

```

TYPE K B1 HETE BUCK 1.40181E-03 ;
assertS FLUX :: 'K-INFINITY' 1 1.222947 ;
EDITION := EDI: EDITION MACRO TRACK FLUX ::
  EDIT 2 SAVE ;
FLUX := FLU: FLUX SYS MACRO TRACK ::
  TYPE B B1 HETE KEFF 1.228007 ;
assertS FLUX :: 'K-INFINITY' 1 1.227979 ;
EDITION := EDI: EDITION MACRO TRACK FLUX ::
  EDIT 2 SAVE ;
FLUX := FLU: FLUX SYS MACRO TRACK ::
  TYPE B B1 HETE R BUCK Z 5.00993E-04 ;
assertS FLUX :: 'K-INFINITY' 1 1.222990 ;
EDITION := EDI: EDITION MACRO TRACK FLUX ::
  EDIT 2 SAVE ;
FLUX := FLU: FLUX SYS MACRO TRACK ::
  TYPE B B1 HETE Z BUCK R 1.001986E-03 ;
assertS FLUX :: 'K-INFINITY' 1 1.223001 ;
EDITION := EDI: EDITION MACRO TRACK FLUX ::
  EDIT 2 SAVE ;
FLUX := FLU: FLUX SYS MACRO TRACK ::
  TYPE B B1 HETE ;
assertS FLUX :: 'K-INFINITY' 1 1.223001 ;
EDITION := EDI: EDITION MACRO TRACK FLUX ::
  EDIT 2 SAVE ;
FLUX := FLU: FLUX SYS MACRO TRACK ::
  TYPE L B1 HETE R BUCK Z 5.00993E-04 ;
assertS FLUX :: 'K-INFINITY' 1 1.222994 ;
EDITION := EDI: EDITION MACRO TRACK FLUX ::
  EDIT 2 SAVE ;
FLUX := FLU: FLUX SYS MACRO TRACK ::
  TYPE L B1 HETE Z BUCK R 1.001986E-03 ;
assertS FLUX :: 'K-INFINITY' 1 1.223001 ;
EDITION := EDI: EDITION MACRO TRACK FLUX ::
  EDIT 2 SAVE ;
FLUX := FLU: FLUX SYS MACRO TRACK ::
  TYPE L B1 HETE ;
assertS FLUX :: 'K-INFINITY' 1 1.222996 ;
EDITION := EDI: EDITION MACRO TRACK FLUX ::
  EDIT 2 SAVE ;
TRKSPC := DELETE: TRKSPC ;
ECHO "test TCM05 completed" ;
END ;
QUIT "LIST" .

```

#### 8.4.6 (TCM06) – Buckling search without fission source

This test is for an homogeneous water cell. A buckling eigenvalue problem is solved in the absence of fission source for the neutron flux distribution inside this cell.

Input data for test case: **TCM06.x2m**

```

*----
* TEST CASE TCM06
* MACROSCOPIC CROSS SECTIONS

```

```

*   BUCKLING SEARCH PROBLEM WITHOUT FISSION SOURCE
*   HOMOGENEOUS GEOMETRY
*
*   REF: none
*-----
*   Define STRUCTURES and MODULES used
*-----
LINKED_LIST
  WATER TRACK MACRO SYS FLUX EDITION ;
MODULE
  GEO: SYBILT: MAC: ASM: FLU: EDI: END: ;
PROCEDURE asserts ;
*-----
*   Macroscopic XS
*-----
MACRO := MAC: ::
  EDIT 2 NGRO 1 ANIS 2 NMIX 1 NIFI 0
  READ INPUT
  MIX 1 TOTAL 3.59 SCAT 1 1 3.57 1 1 2.38
  ;
*-----
*   Geometry : WATER - Homogeneous geometry
*   Tracking : SYBILT
*-----
WATER := GEO: :: HOMOGE
  MIX 1
  ;
TRACK := SYBILT: WATER ::
  TITLE 'TCM06: ENE6101 EXAM'
  MAXR 1
  ;
*-----
*   Solution : TYPE L
*   Leakage : B0 PNL, P0 PNL, B1 PNL, P1 PNL
*-----
SYS := ASM: MACRO TRACK ;
FLUX := FLU: SYS MACRO TRACK ::
  TYPE L B0 SIGS EXTE 5 1.0E-5 BUCK -0.07 ;
asserts FLUX :: 'B2 B1HOM' 1 -2.14440E-01 ;
EDITION := EDI: MACRO TRACK FLUX ::
  EDIT 3 SAVE ;
FLUX := FLU: FLUX SYS MACRO TRACK ::
  TYPE L P0 SIGS EXTE 5 1.0E-5 BUCK -0.07 ;
asserts FLUX :: 'B2 B1HOM' 1 -2.15400E-01 ;
EDITION := EDI: EDITION MACRO TRACK FLUX ::
  EDIT 3 SAVE ;
FLUX := FLU: FLUX SYS MACRO TRACK ::
  TYPE L B1 SIGS EXTE 5 1.0E-5 BUCK -0.07 ;
asserts FLUX :: 'B2 B1HOM' 1 -7.22773E-02 ;
EDITION := EDI: EDITION MACRO TRACK FLUX ::
  EDIT 3 SAVE ;
FLUX := FLU: FLUX SYS MACRO TRACK ::
  TYPE L P1 SIGS EXTE 5 1.0E-5 BUCK -0.07 ;
asserts FLUX :: 'B2 B1HOM' 1 -7.25999E-02 ;
EDITION := EDI: EDITION MACRO TRACK FLUX ::

```



```

EDIT 3 SAVE ;
ECHO "test TCM06 completed" ;
END: ;
QUIT "LIST" .

```

#### 8.4.7 (TCM07) – Test of boundary conditions

This test is for a 2-D Cartesian cell with reflective and void boundary conditions.

Input data for test case: **TCM07.x2m**

```

*-----
* TEST CASE TCM07
* MACROSCOPIC CROSS SECTIONS
* FISSION SOURCE PROBLEM
* 2-D CARTESIAN CELL
* REFLECTIVE AND VOID BOUNDARY CONDITIONS
*
* REF: none
*-----
* Define STRUCTURES and MODULES used
*-----
LINKED_LIST
  MACRO LATGEOR LATREGR SYSR FLUXR EDITR
    LATGEOV LATREGV SYSV FLUXV EDITV ;
SEQ_BINARY
  TRKR TRKV ;
MODULE
  MAC: GEO: EXCELT: ASM: FLU: EDI: DELETE: END: ;
PROCEDURE asserts ;
*-----
* Macroscopic XS
*-----
MACRO := MAC: ::
  NGRO 1 NMIX 2 NIFI 1
  READ INPUT
  MIX 1 TOTAL 0.75 SCAT 1 1 0.50 NUSIGF 1.00 CHI 1.0
  MIX 2 TOTAL 0.75 SCAT 1 1 0.50
  ;
*-----
* Geometry : LATGEOR - Cartesian 2D with reflection BC
*           LATGEOV - Cartesian 2D with void BC
* Tracking : EXCELT
*-----
LATGEOR := GEO: :: CAR2D 2 2
  X- REFL X+ REFL MESHX 0.00 1.0 2.00 SPLITX 4 4
  Y- REFL Y+ REFL MESHY 0.00 1.0 2.00 SPLITY 4 4
  MIX 1 2 2 2 ;
LATGEOV := GEO: LATGEOR ::
  X- VOID X+ VOID Y- VOID Y+ VOID ;
LATREGR TRKR := EXCELT: LATGEOR ::
  TITLE 'LATHROP *** P1 ANISOTROPE '
  MAXR 64 TRAK TISO 49 20.0 ;
LATREGV TRKV := EXCELT: LATGEOV ::

```

```

      TITLE 'LATHROP *** P1 ANISOTROPE '
      MAXR 64 TRAK TISO 49 20.0 ;
*-----
*   Solution : TYPE K
*-----
SYSR := ASM: MACRO LATREGR TRKR ;
FLUXR := FLU: SYSR MACRO LATREGR ::
      TYPE K ACCE 3 0 ;
assertS FLUXR :: 'K-EFFECTIVE' 1 1.687038 ;
EDITR := EDI: MACRO LATREGR FLUXR ::
      EDIT 1 ;
SYSV := ASM: MACRO LATREGV TRKV ;
FLUXV := FLU: SYSV MACRO LATREGV ::
      TYPE K ACCE 3 0 ;
assertS FLUXV :: 'K-EFFECTIVE' 1 0.6779595 ;
EDITV := EDI: MACRO LATREGV FLUXV ::
      EDIT 1 ;
LATGEOR LATREGR SYSR FLUXR EDITR TRKR
      LATGEOR LATREGV SYSV FLUXV EDITV TRKV := DELETE:
LATGEOR LATREGR SYSR FLUXR EDITR TRKR
      LATGEOR LATREGV SYSV FLUXV EDITV TRKV ;
MACRO := DELETE: MACRO ;
ECHO "test TCM07 completed" ;
END: ;
QUIT "LIST" .

```

#### 8.4.8 (TCM08) – Fixed source problem with fission

This test is for a 2-D Cartesian cell which contains both a fission and a fixed source.

Input data for test case: **TCM08.x2m**

```

*-----
*   TEST CASE TCM08
*   MACROSCOPIC CROSS SECTIONS
*   FIXED SOURCE PROBLEM WITH FISSILE MATERIAL
*   FOR 1/8 7X7 PWR ASSEMBLY
*
*   REF: TCM02
*-----
*   Define STRUCTURES and MODULES used
*-----
LINKED_LIST
      PWRF TRACF SYSF FLUXF EDITF PWRS TRACS SYSS FLUXS EDITS MACRO ;
SEQ_BINARY
      PWRTRKF PWRTRKS ;
MODULE
      GEO: EXCELT: MAC: ASM: FLU: EDI: DELETE: END: ;
PROCEDURE assertS assertV ;
*-----
*   Macroscopic XS
*-----
MACRO   :=      MAC:      ::
      NGRO 1 NMIX 4 NIFI 1

```

```

READ INPUT
MIX 1 TOTAL 1.250 SCAT 1 1 1.242
      NUSIGF 0.15 CHI 1.0
MIX 2 TOTAL 0.625 SCAT 1 1 0.355
      FIXE 0.000
MIX 3 TOTAL 14.000 SCAT 1 1 0.000
      FIXE 1.000
MIX 4 TOTAL 1.250 SCAT 1 1 1.242
      FIXE 0.000
;
*-----
* Geometry : PWRF - Cartesian 2D assembly with fission
*           PWRs - Cartesian 2D assembly without fission
* Tracking : EXCELT
*-----
PWRF := GEO: :: CAR2D 4 4
X- DIAG X+ REFL Y- SYME Y+ DIAG
CELL P F F F
      F F F
      F F
      F
::: F := GEO: CARCEL 1
RADIUS 0.000 0.450
MIX 2 1
MESHX -0.625 0.625 SPLITX 2
MESHY -0.625 0.625 SPLITY 2 ;
::: P := GEO: F
MIX 3 1
SPLITR 3 ;
;
PWRs := GEO: :: CAR2D 4 4
X- DIAG X+ REFL Y- SYME Y+ DIAG
CELL P F F F
      F F F
      F F
      F
::: F := GEO: CARCEL 1
RADIUS 0.000 0.450
MIX 2 4
MESHX -0.625 0.625 SPLITX 2
MESHY -0.625 0.625 SPLITY 2 ;
::: P := GEO: F
MIX 3 4
SPLITR 3 ;
;
TRACF PWRTRKF := EXCELT: PWRF ::
TITLE 'TCM08: STANKOVSKI PWR ASSEMBLY'
MAXR 58 TRAK TISO 12 8.0 ;
SYSF := ASM: MACRO TRACF PWRTRKF ;
TRACS PWRTRKS := EXCELT: PWRs ::
TITLE 'TCM08: STANKOVSKI PWR ASSEMBLY'
MAXR 58 TRAK TISO 12 8.0 ;
SYSS := ASM: MACRO TRACS PWRTRKS ;
*-----
* Solution : TYPE K to test if k < 1.0

```

```

*           TYPE S to include fixed source
*-----
FLUXF := FLU: SYSF MACRO TRACF ::
  TYPE K ;
assertS FLUXF :: 'K-EFFECTIVE' 1 0.8165358 ;
EDITF := EDI: MACRO TRACF FLUXF ::
  EDIT 2 SAVE
  MERGE REGION
  1 1 1 2 3 4 3 4 5 6 5 6 7 8 7 8
  9 10 9 10 9 10 11 12 11 12 11 12 11 12 13 14 13 14 13 14
  15 16 15 16 15 16 17 18 17 18 17 18 17 18
  19 20 19 20 19 20 ;
EDITF := DELETE: EDITF ;
*-----
* SINCE KEFF < 1 DO FIXED SOURCE PROBLEM
* (FIXED AND FISSION SOURCES TAKEN INTO ACCOUNT)
*-----
FLUXF := FLU: FLUXF SYSF MACRO TRACF ::
  TYPE S ;
EDITF := EDI: MACRO TRACF FLUXF ::
  EDIT 2 SAVE
  MERGE REGION
  1 1 1 2 3 4 3 4 5 6 5 6 7 8 7 8
  9 10 9 10 9 10 11 12 11 12 11 12 11 12 13 14 13 14 13 14
  15 16 15 16 15 16 17 18 17 18 17 18 17 18
  19 20 19 20 19 20 ;
*-----
* Solution : TYPE S only since no fission
*-----
*
* IF KEFF < 1 DO FIXED SOURCE PROBLEM PROBLEM
* (FIXED AND FISSION SOURCES TAKEN INTO ACCOUNT)
*
FLUXS := FLU: SYSS MACRO TRACS ::
  TYPE S ;
assertV FLUXS :: 'FLUX' (*GROUP*) 1 (*REGION*) 10 6.728200E-03 ;
EDITS := EDI: MACRO TRACS FLUXS ::
  EDIT 2 SAVE
  MERGE REGION
  1 1 1 2 3 4 3 4 5 6 5 6 7 8 7 8
  9 10 9 10 9 10 11 12 11 12 11 12 11 12 13 14 13 14 13 14
  15 16 15 16 15 16 17 18 17 18 17 18 17 18
  19 20 19 20 19 20 ;
PWRTRKS PWRTRKF := DELETE: PWRTRKS PWRTRKF ;
ECHO "test TCM08 completed" ;
END ;
QUIT "LIST" .

```

#### 8.4.9 (TCM09) – Solution of a 2-D fission source problem using MCGGT:

This test case is for a  $3 \times 3$  Cartesian assembly in 2-D similar to TCM03. It is solved using the method of cyclic characteristics.

Input data for test case: **TCM09.x2m**

```

*-----
* TEST CASE TCM09
* MACROSCOPIC CROSS SECTIONS
* FIXED SOURCE PROBLEM
* CARTESIAN 3 X 3 ASSEMBLY
* WATANABE-MAYNARD PROBLEM SIMILAR TO TCM09
*
* REF: R. Roy, "The Cyclic Characteristics Method,"
*       Int. Conf. Physics of Nuclear Science and Technology,
*       Long Island, NY, October 1998, pp. 407-414.
*-----
*
LINKED_LIST WATA WAT24 TRACK MACRO SYS FLUX EDITION ;
SEQ_BINARY WATATRK ;
STRING PolarAng := "CACB" ;
MODULE GEO: EXCELT: MCCGT: MAC: ASM: FLU: EDI: DELETE: END: ;
PROCEDURE assertV ;
*
* MACROSCOPIC CROSS SECTIONS
MACRO := MAC: ::
  NGRO 1 NMIX 3
  READ INPUT
    MIX 1 TOTAL 0.2 SCAT 1 1 0.19 FIXE 6.4
    MIX 2 TOTAL 0.2 SCAT 1 1 0.19
    MIX 3 TOTAL 0.0 SCAT 1 1 0.00 ;
* GEOMETRIES ENTERED WITH SYMMETRIES
* WAT24 - 24 X 24 REGIONS
WATA := GEO: :: CAR2D 3 3
  X- DIAG X+ VOID
  MESHX 0.00 1.25 5.00 10.00
  Y- REFL Y+ DIAG
  MESHY 0.00 1.25 5.00 10.00
  MIX      1      3      2
           3      2
           2      ;

WAT24 := GEO: WATA ::
  SPLITX 3 9 12
  SPLITY 3 9 12 ;
* SOLUTION FOR WAT24
TRACK WATATRK := EXCELT: WAT24 ::
  TITLE 'TCM09: WATANABE-MAYNARD 24X24 '
  MAXR 300
  TRAK TSPC 12 12.0 ;
TRACK := MCCGT: TRACK WATATRK ::
  EDIT 1 <<PolarAng>> 4
  AAC 80 TMT EPSI 1E-5 MCU 2500
  MAXI 1 KRYL 0 SCR 0 HDD 0.0 ;
SYS := ASM: MACRO TRACK WATATRK ::
  EDIT 2 ARM ;
FLUX := FLU: MACRO TRACK SYS WATATRK ::
  TYPE S THER 1.E-6 100 EXTE 1.E-6 100 ;
* UPPER QUADRANT FLUX FOR 24X24
* RESULTS GIVEN IN TABLE 1. (ref. p. 411 )
EDITION := EDI: FLUX MACRO TRACK ::

```



```

                                0 0
                                0
;
WATATRK := DELETE: WATATRK ;
assertV FLUX :: 'FLUX' (*GROUP*) 1 (*REGION*) 30 4.896158 ;
ECHO "test TCM09 completed" ;
END: ;
QUIT "LIST" .

```

#### 8.4.10 (TCM10) – Solution of a 2-D fixed source problem using MCGGT:

This test case is for a 2-D Cartesian assembly that contains a fixed source. It is solved using the method of cyclic characteristics.

Input data for test case: **TCM10.x2m**

```

*
* TEST CASE TCM10
* MACROSCOPIC CROSS SECTIONS
* FIXED SOURCE PROBLEM
* CARTESIAN 2 X 2 ASSEMBLY
* TSAI-LOYALKA SEMI-INFINITE PROBLEM
*
* REF: R. Roy, "The Cyclic Characteristics Method,"
*       Int. Conf. Physics of Nuclear Science and Technology,
*       Long Island, NY, October 1998, pp. 407-414.
*
LINKED_LIST LOYA LOY25 TRACK FLUX EDITION
          MACRO SYS MACRO100 MACRO050 MACRO010 MACRO005 MACRO000 ;
SEQ_BINARY LOYATRK ;
STRING PolarAng := "CACB" ;
MODULE GEO: EXCELT: MCGGT: MAC: ASM: FLU: EDI: DELETE: END: ;
PROCEDURE assertV ;
INTEGER i n := 1 1 ;
*
* MACROSCOPIC CROSS SECTIONS
MACRO100 := MAC: ::
  NGRO 1 NMIX 2
  READ INPUT
    MIX 1 TOTAL 1.0 SCAT 1 1 1.00 FIXE 1.0
    MIX 2 TOTAL 1.0 SCAT 1 1 1.00 ;
MACRO050 := MAC: ::
  NGRO 1 NMIX 2
  READ INPUT
    MIX 1 TOTAL 1.0 SCAT 1 1 0.50 FIXE 1.0
    MIX 2 TOTAL 1.0 SCAT 1 1 0.50 ;
MACRO010 := MAC: ::
  NGRO 1 NMIX 2
  READ INPUT
    MIX 1 TOTAL 1.0 SCAT 1 1 0.10 FIXE 1.0
    MIX 2 TOTAL 1.0 SCAT 1 1 0.10 ;
MACRO005 := MAC: ::
  NGRO 1 NMIX 2
  READ INPUT

```

```

      MIX 1 TOTAL 1.0 SCAT 1 1 0.05 FIXE 1.0
      MIX 2 TOTAL 1.0 SCAT 1 1 0.05 ;
MACRO000 := MAC: ::
      NGRO 1 NMIX 2
      READ INPUT
      MIX 1 TOTAL 1.0 SCAT 1 1 0.00 FIXE 1.0
      MIX 2 TOTAL 1.0 SCAT 1 1 0.00 ;
* GEOMETRIES ENTERED WITH SYMMETRIES
* LOYA - 2 X 2 REGIONS
* LOY25 - 25 X 25 REGIONS
LOYA := GEO: :: CAR2D 2 2
      X- REFL X+ VOID
      MESHX 0.00 0.52 1.00
      Y- REFL Y+ REFL
      MESHY 0.00 0.52 1.00
      MIX      1      2
              2      2      ;
LOY25 := GEO: LOYA ::
      SPLITX 13 12
      SPLITY 13 12      ;
* SOLUTION FOR LOY25
TRACK LOYATRK := EXCELT: LOY25 ::
      TITLE 'TCM10: LOYANABE-MAYNARD 24X24 '
      MAXR 625
      TRAK TSPC 12 100.0 ;
TRACK := MCCGT: TRACK LOYATRK ::
      EDIT 1 <<PolarAng>> 2
      AAC 1 TMT SCR 0 EPSI 1E-5
      MAXI 100 KRYL 30 HDD 0.0 ;
REPEAT
IF i 1 = THEN
      MACRO := MACRO100 ;
ELSEIF i 2 = THEN
      MACRO := MACRO050 ;
ELSEIF i 3 = THEN
      MACRO := MACRO010 ;
ELSEIF i 4 = THEN
      MACRO := MACRO005 ;
ELSEIF i 5 = THEN
      MACRO := MACRO000 ;
ENDIF ;
SYS := ASM: MACRO TRACK LOYATRK ::
      EDIT 2 ARM ;
FLUX := FLU: MACRO TRACK SYS LOYATRK ::
      TYPE S ;
* SOLUTION FOR LOY25
* FLUX AT X=Y= 0.50, 0.70 AND 0.98
* SEE TABLE 2. (ref. p. 412)
EDITION := EDI: FLUX MACRO TRACK ::
      EDIT 2 SAVE
      MERGE REGION
      0 0 0 0 0 0 0 0 0 0 0 0 0 0 0 0 0 0 0 0 0 0 0 0 0 0
      0 0 0 0 0 0 0 0 0 0 0 0 0 0 0 0 0 0 0 0 0 0 0 0 0 0
      0 0 0 0 0 0 0 0 0 0 0 0 0 0 0 0 0 0 0 0 0 0 0 0 0 0
      0 0 0 0 0 0 0 0 0 0 0 0 0 0 0 0 0 0 0 0 0 0 0 0 0 0

```



```

0 0 0 0 0 0 0 0 0 0 0 0 0 0 0 0
0 0 0 0 0 0 0 0 0 0 0 0 0 0 0 0
0 0 0 0 0 0 0 0 0 0 0 0 0 0 0 0
0 0 0 0 0 0 0 0 0 0 0 0 0 0 0 0
0 0 0 0 0 0 0 0 0 0 0 0 0 0 0 0
0 0 0 0 0 0 0 0 0 0 0 0 0 0 0 0

0 0 0 0 0 0 0 0 0 0 0 0 0 0 0 0
0 0 0 0 0 0 0 0 0 0 0 0 0 0 0 0
0 0 0 0 0 0 0 0 1 0 0 0 0 0 0 0
0 0 0 0 0 0 0 0 0 0 0 0 0 0 0 0
0 0 0 0 0 0 0 0 0 0 0 0 0 0 0 0

0 0 0 0 0 0 0 0 0 0 0 0 0 0 0 0
0 0 0 0 0 0 0 0 0 0 0 0 0 0 0 0
0 0 0 0 0 0 0 0 0 0 0 0 2 0 0 0
0 0 0 0 0 0 0 0 0 0 0 0 0 0 0 0
0 0 0 0 0 0 0 0 0 0 0 0 0 0 0 0

0 0 0 0 0 0 0 0 0 0 0 0 0 0 0 0
0 0 0 0 0 0 0 0 0 0 0 0 0 0 0 0
0 0 0 0 0 0 0 0 0 0 0 0 0 0 0 0
0 0 0 0 0 0 0 0 0 0 0 0 0 0 0 0
0 0 0 0 0 0 0 0 0 0 0 0 0 0 0 3
;
IF i 1 = THEN
  assertV FLUX :: 'FLUX' (*GROUP*) 1 (*REGION*) 30 1.708198 ;
ELSEIF i 2 = THEN
  assertV FLUX :: 'FLUX' (*GROUP*) 1 (*REGION*) 30 0.7793926 ;
ELSEIF i 3 = THEN
  assertV FLUX :: 'FLUX' (*GROUP*) 1 (*REGION*) 30 0.5732016 ;
ELSEIF i 4 = THEN
  assertV FLUX :: 'FLUX' (*GROUP*) 1 (*REGION*) 30 0.5556656 ;
ELSEIF i 5 = THEN
  assertV FLUX :: 'FLUX' (*GROUP*) 1 (*REGION*) 30 0.5392905 ;
ENDIF ;
SYS FLUX MACRO EDITION := DELETE: SYS FLUX MACRO EDITION ;
EVALUATE i := i 1 + ;
UNTIL i 6 = ;
LOYATRK := DELETE: LOYATRK ;
ECHO "test TCM10 completed" ;
END: ;
QUIT "LIST" .

```

#### 8.4.11 (TCM11) – Comparison of CP and MoC solutions

This test case is for a  $4 \times 4$  Cartesian assembly in 2-D. It is solved using the method of cyclic characteristics and the method of collision probabilities using specular (mirror like) boundary conditions.

Input data for test case: **TCM11.x2m**

```

*
* TEST CASE TCM11
* MACROSCOPIC CROSS SECTIONS
* FIXED SOURCE PROBLEM
* CARTESIAN 4 X 4 ASSEMBLY WITH FUEL RODS AND POISON
* KAVENOKY BENCHMARK
*
* REF: R. Roy, "The Cyclic Characteristics Method,"
*       Int. Conf. Physics of Nuclear Science and Technology,
*       Long Island, NY, October 1998, pp. 407-414.
*
STRING Polar_Ang := "CACB" ;
INTEGER  Nazimuth := 8 ;
REAL     DenTrak  := 100. ;
INTEGER  Nsplit   := 5 ;
REAL     Tolerance := 5.E-6 ;
LINKED_LIST PWR TRACK MACRO SYS FLUX EDITION ;
SEQ_BINARY PWRTRK ;
MODULE GEO: EXCELT: MCCGT: MAC: ASM: FLU: EDI: END: DELETE: GREP: ;
PROCEDURE assertV ;
REAL ou := 100. ;
REAL
  f1 f2 f3 f8 f9 f10 f11 f12 f13 f14 f15
  v1 v2 v3 v8 v9 v10 v11 v12 v13 v14 v15 ;
REAL
  r1      r2      r3
           r8      r9      r10
  r11     r12     r13     r14     r15 :=
  5.166   3.699   4.183
           3.178   3.617   0.2847
  2.913   3.441   3.937   3.225   3.673 ;
REAL
  e1      e2      e3
           e8      e9      e10
  e11     e12     e13     e14     e15 :=
  0.11    0.08    0.07
           0.04    0.05    0.002
  0.03    0.03    0.04    0.05    0.05 ;
EVALUATE
  e1      e2      e3
           e8      e9      e10
  e11     e12     e13     e14     e15 :=
  e1 r1 / e2 r2 / e3 r3 /
           e8 r8 / e9 r9 / e10 r10 /
  e11 r11 / e12 r12 / e13 r13 / e14 r14 / e15 r15 / ;
EVALUATE
  e1      e2      e3
           e8      e9      e10
  e11     e12     e13     e14     e15 :=
  e1 ou * e2 ou * e3 ou *
           e8 ou * e9 ou * e10 ou *
  e11 ou * e12 ou * e13 ou * e14 ou * e15 ou * ;
*----
* Macroscopic XS

```

```

*-----
MACRO := MAC: ::
  NGRO 1 NMIX 19
  READ INPUT
  MIX 1 TOTAL 1.250 SCAT 1 1 1.242 FIXE 1.000
  MIX 2 TOTAL 0.625 SCAT 1 1 0.355 FIXE 0.000
  MIX 3 TOTAL 1.250 SCAT 1 1 1.242 FIXE 1.000
  MIX 4 TOTAL 0.625 SCAT 1 1 0.355 FIXE 0.000
  MIX 5 TOTAL 1.250 SCAT 1 1 1.242 FIXE 1.000
  MIX 6 TOTAL 0.625 SCAT 1 1 0.355 FIXE 0.000
  MIX 7 TOTAL 1.250 SCAT 1 1 1.242 FIXE 1.000
  MIX 8 TOTAL 0.625 SCAT 1 1 0.355 FIXE 0.000
  MIX 9 TOTAL 1.250 SCAT 1 1 1.242 FIXE 1.000
  MIX 10 TOTAL 14.000 SCAT 1 1 0.000 FIXE 0.000
  MIX 11 TOTAL 1.250 SCAT 1 1 1.242 FIXE 1.000
  MIX 12 TOTAL 0.625 SCAT 1 1 0.355 FIXE 0.000
  MIX 13 TOTAL 1.250 SCAT 1 1 1.242 FIXE 1.000
  MIX 14 TOTAL 0.625 SCAT 1 1 0.355 FIXE 0.000
  MIX 15 TOTAL 1.250 SCAT 1 1 1.242 FIXE 1.000
  MIX 16 TOTAL 0.625 SCAT 1 1 0.355 FIXE 0.000
  MIX 17 TOTAL 1.250 SCAT 1 1 1.242 FIXE 1.000
  MIX 18 TOTAL 0.625 SCAT 1 1 0.355 FIXE 0.000
  MIX 19 TOTAL 1.250 SCAT 1 1 1.242 FIXE 1.000
  ;
*-----
* Geometry : PWR - Cartesian 7x7
* Tracking : EXCELT
*-----
PWR := GEO: :: CAR2D 4 4
  X- DIAG X+ REFL Y- SYME Y+ DIAG
  CELL WA F2 F4 F6
        F8 P10 F12
        F14 F16
        F18
  ::: WA := GEO: CAR2D 1 1
    MESHX -0.625 0.625 SPLITX <<Nsplitt>>
    MESHY -0.625 0.625 SPLITY <<Nsplitt>>
    MIX 1 ;
  ::: F2 := GEO: CARCEL 1
    MESHX -0.625 0.625 SPLITX <<Nsplitt>>
    MESHY -0.625 0.625 SPLITY <<Nsplitt>>
    RADIUS 0.000 0.450
    MIX 2 3 ;
  ::: F4 := GEO: F2
    MIX 4 5 ;
  ::: F6 := GEO: F2
    MIX 6 7 ;
  ::: F8 := GEO: F2
    MIX 8 9 ;
  ::: P10 := GEO: F2
    MIX 10 11 SPLITR 3 ;
  ::: F12 := GEO: F2
    MIX 12 13 ;
  ::: F14 := GEO: F2
    MIX 14 15 ;

```

```

::: F16 := GEO: F2
  MIX      16    17      ;
::: F18 := GEO: F2
  MIX      18    19      ;
;
TRACK PWRTRK := EXCELT: PWR ::
  MAXR 300 TRAK TSPC <<Nazimuth>> <<DenTrak>> ;
TRACK := MCCGT: TRACK PWRTRK ::
  EDIT 1 <<Polar_Ang>> 4
  AAC 80 TMT EPSI 1E-5
  MAXI 1 KRYL 0 SCR 0 HDD 0.0 ;
SYS := ASM: MACRO TRACK PWRTRK ::
  EDIT 2 ARM ;
FLUX := FLU: MACRO TRACK SYS PWRTRK ::
  TYPE S
  THER <<Tolerance>> 100 EXTE <<Tolerance>> 100 ;
EDITION := EDI: FLUX MACRO TRACK ::
  EDIT 2 SAVE
  MERGE MIX 1 2 3 0 0 0 0 4 5 6 7 8 9 10 11 0 0 0 0 ;
GREP: EDITION ::
  STEP UP 'REF-CASE0001' STEP UP MACROLIB
  GETVAL VOLUME 1 11
  >>v1<< >>v2<< >>v3<< >>v8<< >>v9<< >>v10<<
  >>v11<< >>v12<< >>v13<< >>v14<< >>v15<<
  STEP UP 'GROUP' STEP AT 1
  GETVAL FLUX-INTG 1 11
  >>f1<< >>f2<< >>f3<< >>f8<< >>f9<< >>f10<<
  >>f11<< >>f12<< >>f13<< >>f14<< >>f15<<
;
EVALUATE f1 f2 f3 f8 f9 f10 f11 f12 f13 f14 f15 :=
      f1 v1 / r1 - r1 / ou *
      f2 v2 / r2 - r2 / ou *
      f3 v3 / r3 - r3 / ou *
      f8 v8 / r8 - r8 / ou *
      f9 v9 / r9 - r9 / ou *
      f10 v10 / r10 - r10 / ou *
      f11 v11 / r11 - r11 / ou *
      f12 v12 / r12 - r12 / ou *
      f13 v13 / r13 - r13 / ou *
      f14 v14 / r14 - r14 / ou *
      f15 v15 / r15 - r15 / ou *
;
* SOLUTION FOR KAVENORY BENCHMARK
* FLUX VALUES COMPARED TO MONTE-CARLO RESULTS
* SEE TABLE 3. (ref. p. 412)
ECHO "DF( 1/ 3)%=" f1 f2 f3 ;
ECHO "DF( 8/ 9)%=" f8 f9 ;
ECHO "DF(10/12)%=" f10 f11 f12 ;
ECHO "DF(13/15)%=" f13 f14 f15 ;
ECHO "ACCEPT=" f1 ABS e1 <= f2 ABS e2 <= f3 ABS e3 <= ;
ECHO "ACCEPT=" f8 ABS e8 <= f9 ABS e9 <= ;
ECHO "ACCEPT=" f10 ABS e10 <= f11 ABS e11 <= f12 ABS e12 <= ;
ECHO "ACCEPT=" f13 ABS e13 <= f14 ABS e14 <= f15 ABS e15 <= ;
PWRTRK := DELETE: PWRTRK ;
assertV FLUX :: 'FLUX' (*GROUP*) 1 (*REGION*) 30 3.84262705 ;

```

```
ECHO "test TCM11 completed" ;
END: ;
QUIT .
```

#### 8.4.12 (TCM12) - Solution of a 3-D problem using the MCU: module

This test case is for a simplified 3-D Cartesian assembly analyzed using the EXCELT:. A collisions probability solution is generated as well as two solutions using the method of characteristics.

Input data for test case: **TCM12.x2m**

```
*
* TEST CASE TCM12
* MACROSCOPIC CROSS SECTIONS
* FISSION SOURCE PROBLEM
* 3D HEXAGONAL S30 ASSEMBLY WITH FUEL RODS
*
LINKED_LIST GEOMETRY TRACKING ASSEMBLY MACLIB FLUX ;
MODULE MAC: GEO: EXCELT: ASM: FLU: TRIVAT: END: ;
SEQ_BINARY TRKSPC ;
PROCEDURE asserts ;

MACLIB := MAC: ::
  EDIT 2 NGRO 1 NMIX 4 NIFI 1
    READ INPUT
    MIX 1
      TOTAL 0.41          SCAT 1 1 0.3
      NUSIGF 0.1          CHI 1.0
    MIX 2
      TOTAL 0.53          SCAT 1 1 0.5
    MIX 3
      TOTAL 0.45          SCAT 1 1 0.347
      NUSIGF 0.17         CHI 1.0
    MIX 4
      TOTAL 0.3           SCAT 1 1 0.2
      NUSIGF 0.1          CHI 1.0
  ;

GEOMETRY := GEO: :: HEXZ 2 2
  EDIT 2
  HBC S30 REFL Z+ REFL Z- REFL
  MIX UDEPLETED_1 UDEPLETED_1 UDEPLETED_2 UDEPLETED_2
  ::: UDEPLETED_1 := GEO: HEXCELZ 4 1
    EDIT 2
    SIDE 2.804
    RADIUS 0.0 2.23 2.275 2.4 2.5
    MESHZ 0.0 0.7
    MIX 1 3 4 2 2 ;
  ::: UDEPLETED_2 := GEO: HEXCELZ 4 1
    EDIT 2
    SIDE 2.804
    RADIUS 0.0 2.23 2.275 2.4 2.5
    MESHZ 0.7 1.0
    MIX 4 3 1 2 2 ;
```

```

;
TRACKING TRKSPC := EXCELT: GEOMETRY ::
  EDIT 2
  MAXR 200 TRAK TISO 6 10 10. 5.
;

ASSEMBLY := ASM: MACLIB TRACKING TRKSPC :: EDIT 1 ;
FLUX := FLU: ASSEMBLY MACLIB TRACKING TRKSPC :: TYPE K ;
assertS FLUX :: 'K-EFFECTIVE' 1 0.9292231 ;
ECHO "test TCM12 completed" ;
END: ;
QUIT .

```

#### 8.4.13 (TCM13) - Hexagonal assembly with hexagonal cells containing clusters

This test represents an example of a 2-D hexagonal assembly filled with triangular/hexagonal cells containing clusters (see Figure 37) that can be analyzed with NXT:.

*Colored by Region*

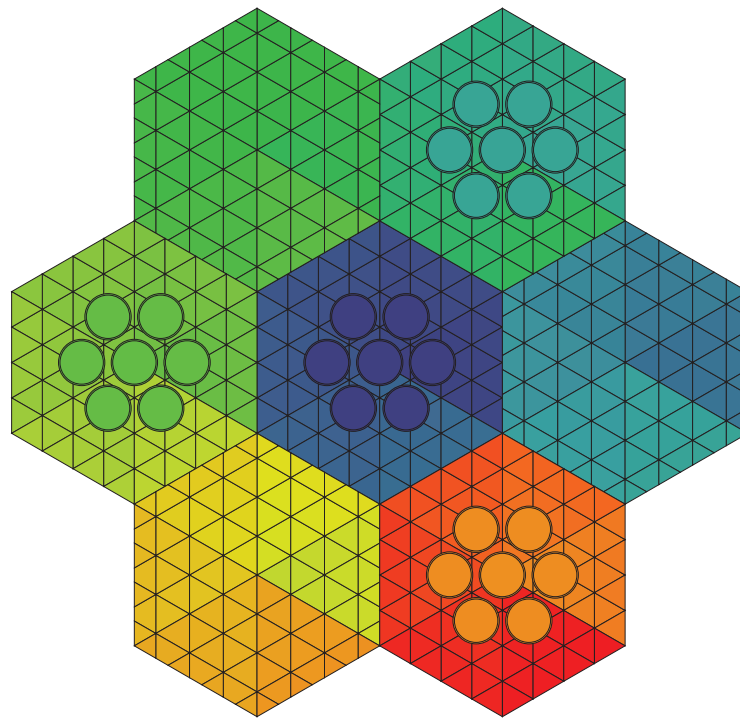

Figure 37: Geometry of a 2-D hexagonal assembly filled with triangular/hexagonal cells.

Input data for test case: **TCM13.x2m**

```

*----
* TEST CASE TCM13
* MACROSCOPIC CROSS SECTIONS
* FISSION SOURCE PROBLEM

```

```

* HEXAGONAL CELL with PINS
*-----
* Define STRUCTURES and MODULES used
*-----
LINKED_LIST  MacLib GlobalGeo Tracking Pij Flux ;
SEQ_ASCII    Fig.ps ;
SEQ_BINARY   Lines ;
MODULE       MAC: GEO: NXT: PSP: ASM: FLU: DELETE: END: ;
PROCEDURE    assertS ;
*-----
* Macroscopic XS
*-----
MacLib := MAC: ::
  NGRO 2 NMIX 18 NIFI 1
  READ INPUT
  MIX 1  TOTAL 0.166667 1.111111
    SCAT  2 2  0.00015 0.126667 2 2 1.10111 0.039
  MIX 2  TOTAL 0.166667 1.111111
    SCAT  2 2  0.00015 0.126667 2 2 1.10111 0.039
  MIX 3  TOTAL 0.166667 1.111111
    SCAT  2 2  0.00015 0.126667 2 2 1.10111 0.039
  MIX 4  TOTAL 0.166667 1.111111
    SCAT  2 2  0.00015 0.126667 2 2 1.10111 0.039
  MIX 5  TOTAL 0.166667 1.111111
    SCAT  2 2  0.00015 0.126667 2 2 1.10111 0.039
  MIX 6  TOTAL 0.166667 1.111111
    SCAT  2 2  0.00015 0.126667 2 2 1.10111 0.039
  MIX 7  TOTAL 0.166667 1.111111
    SCAT  2 2  0.00015 0.126667 2 2 1.10111 0.039
  MIX 8  TOTAL 0.166667 1.111111
    SCAT  2 2  0.00015 0.126667 2 2 1.10111 0.039
  MIX 9  TOTAL 0.166667 1.111111
    SCAT  2 2  0.00015 0.126667 2 2 1.10111 0.039
  MIX 10 TOTAL 0.166667 1.111111
    SCAT  2 2  0.00015 0.126667 2 2 1.10111 0.039
  MIX 11 TOTAL 0.166667 1.111111
    SCAT  2 2  0.00015 0.126667 2 2 1.10111 0.039
  MIX 12 TOTAL 0.166667 1.111111
    SCAT  2 2  0.00015 0.126667 2 2 1.10111 0.039
  MIX 13 TOTAL 0.166667 1.111111
    SCAT  2 2  0.00015 0.126667 2 2 1.10111 0.039
  MIX 14 TOTAL 0.166667 1.111111
    SCAT  2 2  0.00015 0.126667 2 2 1.10111 0.039
  MIX 15 TOTAL 0.166667 1.111111
    SCAT  2 2  0.00015 0.126667 2 2 1.10111 0.039
  MIX 16 TOTAL 0.166667 1.111111
    SCAT  2 2  0.00015 0.126667 2 2 1.10111 0.039
  MIX 17 TOTAL 0.222222 0.833333
    SCAT  1 1  0.19222          2 2 0.75333 0.02
    NUSIGF 0.0 0.170 CHI 1.0 0.0
  MIX 18 TOTAL 0.222222 0.833333
    SCAT  1 1  0.19222          2 2 0.75333 0.02
    NUSIGF 0.0 0.170 CHI 1.0 0.0
;
*-----

```

```

* Geometry : Hexagonal assembly containing
* hexagons with 4 triangular crown and pins
*-----
GlobalGeo := GEO: :: HEX 7
  HBC COMPLETE REFL
  CELL C1 C2 C1 C2 C1 C2 C1
  ::: C1 := GEO: HEXT 4
    SIDE 4.0
    MIX
    1 2 3 4 5 6 7 8 9 10 11 12 13 14 15 16
    1 2 3 4 5 6 7 8 9 10 11 12 13 14 15 16
    1 2 3 4 5 6 7 8 9 10 11 12 13 14 15 16
    1 2 3 4 5 6 7 8 9 10 11 12 13 14 15 16
    1 2 3 4 5 6 7 8 9 10 11 12 13 14 15 16
    1 2 3 4 5 6 7 8 9 10 11 12 13 14 15 16
    CLUSTER ROD1 ROD2
    ::: ROD1 := GEO: TUBE 2 MIX 17 18 NPIN 1 RPIN 0.0000 APIN 0.0000
      RADIUS 0.00000 0.6122 0.6540 ;
    ::: ROD2 := GEO: ROD1 MIX 17 18 NPIN 6 RPIN 1.4885 APIN 0.0000 ;
    ;
  ::: C2 := GEO: HEXT 4
    SIDE 4.0 1.1
    MIX
    1 2 3 4 5 6 7 8 9 10 11 12 13 14 15 16
    1 2 3 4 5 6 7 8 9 10 11 12 13 14 15 16
    1 2 3 4 5 6 7 8 9 10 11 12 13 14 15 16
    1 2 3 4 5 6 7 8 9 10 11 12 13 14 15 16
    1 2 3 4 5 6 7 8 9 10 11 12 13 14 15 16
    1 2 3 4 5 6 7 8 9 10 11 12 13 14 15 16
    ;
  ;
*-----
* Tracking : NXT
* Solution : PIJ
*-----
Lines Tracking := NXT: GlobalGeo ::
  EDIT 2 LONG NORE TISO 3 10.0 ;
Fig.ps := PSP: Tracking ;
Pij := ASM: MacLib Tracking Lines ;
Flux := FLU: Pij MacLib Tracking :: TYPE K ;
assertS Flux :: 'K-EFFECTIVE' 1 0.9896834 ;
Flux Pij := DELETE: Flux Pij ;
GlobalGeo Tracking Lines := DELETE: GlobalGeo Tracking Lines ;
ECHO "test TCM13 completed" ;
END: ;
QUIT "LIST" .

```



## 8.5 WIMSD4 microscopic cross-section examples.

The test cases we will consider here use the `LIB:` module to enter microscopic cross sections taken from a WIMSD4 69 groups library. We will assume that this library is located in file `iaea`. The test cases are numbered successively from (TCWU01) to (TCWU31).

### 8.5.1 (TCWU01) – The Mosteller benchmark.

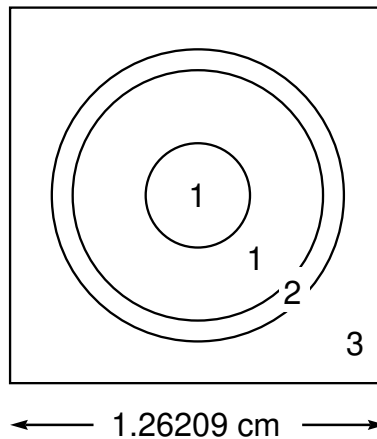

Figure 38: Geometry for the Mosteller benchmark problem.

This benchmark uses both a cartesian 2-D cell with a central annular pin and an equivalent annular cell.<sup>[97]</sup> No depletion information is required in this case since the module `EVO:` will not be executed. A comparison between various calculation options is provided here. We first consider the annular geometry with a `SYBILT:` self-shielding and a `SYBILT:` transport calculation. This is then repeated for the cartesian 2-D cell. Finally, we used an isotropic (`TISO`) and a specular (`TSPC`) `EXCELT:` tracking successively for the self-shielding and transport calculations.

Input data for test case: **TCWU01.x2m**

```
*-----
* TEST CASE TCWU01
* MOSTELLER BENCHMARK: 1-D ANNULAR CELL AND 2-D CARTESIAN CELL
* WIMSD4 69 GROUPS LIBRARY FILE iaea FROM WLUP
*
* REF: R. Mosteller et al. Nucl. Sci. Eng. 107, 265 (1991)
*
*-----
* Define STRUCTURES and MODULES used
*-----
LINKED_LIST
  MOSTELA MOSTELC DISCR LIBRARY CP CALC OUT ;
SEQ_BINARY
  TRKSPC ;
MODULE
  LIB: GEO: SYBILT: EXCELT: SHI: ASM: FLU: EDI: DELETE: END: ;
PROCEDURE asserts ;
*-----
* Microscopic cross sections from file iaea format WIMSD4
*-----
```

```

LIBRARY := LIB: ::
  NMIX 3 CTRA WIMS
  MIXS LIB: WIMSD4 FIL: iaea
  MIX 1 600.0          016      = '6016'      4.61309E-2
    U235      = '2235'    1.66078E-4 1
    U238      = '8238'    2.28994E-2 1
  MIX 2 600.0
    Zr91      = '91'      3.83243E-2
  MIX 3 600.0
    H1H20     = '3001'    4.42326E-2  016H20 = '6016'      2.21163E-2
    BNat      = '1011'    1.02133E-5
  ;
*-----
*   Geometry MOSTELA : annular 3 region geometry
*           MOSTELC : Cartesian 3 region geometry
*-----
MOSTELA := GEO: :: TUBE 3
  R+ REFL RADIUS 0.0 0.39306 0.45802 0.71206 SPLITR 2 1 1
  MIX 1 2 3 ;
MOSTELC := GEO: :: CARCEL 2
  X- REFL X+ REFL MESHX 0.0 1.26209
  Y- REFL Y+ REFL MESHY 0.0 1.26209
  RADIUS 0.0 0.39306 0.45802 SPLITR 2 1
  MIX 1 2 3 ;
*-----
*   Case 1 -- annular
*   Self-Shielding calculation SYBIL
*   Transport calculation      SYBIL
*   Flux calculation for K no leakage
*-----
DISCR := SYBILT: MOSTELA ::
  TITLE 'TCWU01: MOSTELLER BENCHMARK (SYBIL / SYBIL)'
  MAXR 4 QUA1 5 ;
LIBRARY := SHI: LIBRARY DISCR :: EDIT 0 NOLJ ;
CP := ASM: LIBRARY DISCR ;
CALC := FLU: CP LIBRARY DISCR ::
  TYPE K ;
assertS CALC :: 'K-EFFECTIVE' 1 0.8276153 ;
OUT := EDI: LIBRARY DISCR CALC ::
  EDIT 4 MERG MIX 1 2 3 COND 4.0 SAVE ;
DISCR CP := DELETE: DISCR CP ;
*-----
*   Case 2 -- Cartesian
*   Self-Shielding calculation SYBIL
*   Transport calculation      SYBIL
*   Flux calculation for K no leakage
*-----
DISCR := SYBILT: MOSTELC ::
  TITLE 'TCWU01: MOSTELLER BENCHMARK (SYBIL / SYBIL)'
  MAXR 4 QUA1 5 QUA2 6 5 ;
LIBRARY := SHI: LIBRARY DISCR :: EDIT 0 NOLJ ;
CP := ASM: LIBRARY DISCR ;
CALC := FLU: CALC CP LIBRARY DISCR ::
  TYPE K ;
assertS CALC :: 'K-EFFECTIVE' 1 0.8277465 ;

```

```

OUT := EDI: OUT LIBRARY DISCR CALC ::
  EDIT 1 MERG MIX 1 2 3 COND 4.0 STAT ALL REFE 1 ;
DISCR CP := DELETE: DISCR CP ;
*-----
* Case 3 -- annular
* Self-Shielding calculation EXCEL-ISO
* Transport calculation      EXCEL-ISO
* Flux calculation for K no leakage
*-----
DISCR TRKSPC := EXCELT: MOSTELC ::
  TITLE 'TCWU01: MOSTELLER BENCHMARK (EXCELL)'
  MAXR 4 TRAK TISO 12 20.0 ;
LIBRARY := SHI: LIBRARY DISCR TRKSPC :: EDIT 0 NOLJ ;
CP := ASM: LIBRARY DISCR TRKSPC ;
CALC := FLU: CALC CP LIBRARY DISCR ::
  TYPE K ;
assertS CALC :: 'K-EFFECTIVE' 1 0.8287268 ;
OUT := EDI: OUT LIBRARY DISCR CALC ::
  EDIT 1 MERG MIX 1 2 3 COND 4.0 STAT ALL REFE 1 ;
DISCR TRKSPC CP := DELETE: DISCR TRKSPC CP ;
*-----
* Case 4 -- Cartesian
* Self-Shielding calculation EXCEL-SPC
* Transport calculation      EXCEL-SPC
* Flux calculation for K no leakage
*-----
DISCR TRKSPC := EXCELT: MOSTELC ::
  TITLE 'TCWU01: MOSTELLER BENCHMARK (EXCELL)'
  MAXR 4 TRAK TSPC 12 20.0 ;
LIBRARY := SHI: LIBRARY DISCR TRKSPC :: EDIT 0 NOLJ ;
CP := ASM: LIBRARY DISCR TRKSPC ;
CALC := FLU: CALC CP LIBRARY DISCR ::
  TYPE K ;
assertS CALC :: 'K-EFFECTIVE' 1 0.8307597 ;
OUT := EDI: OUT LIBRARY DISCR CALC ::
  EDIT 1 MERG MIX 1 2 3 COND 4.0 STAT ALL REFE 1 ;
DISCR TRKSPC CP := DELETE: DISCR TRKSPC CP ;
ECHO "test TCWU01 completed" ;
END: ;
QUIT "LIST" .

```

### 8.5.2 (TCWU02) – A 17 × 17 PWR type assembly

This test case represents a production calculation of a normal PWR assembly with cell grouping (MERGE and TURN options). Its configuration is shown in Figure 39.

Input data for test case: **TCWU02.x2m**

```

*-----
* TEST CASE TCWU02
* 17 X 17 PWR ASSEMBLY WITHOUT POISON
* WIMSD4 69 GROUPS LIBRARY FILE iaea FROM WLUP
*
* REF: none

```

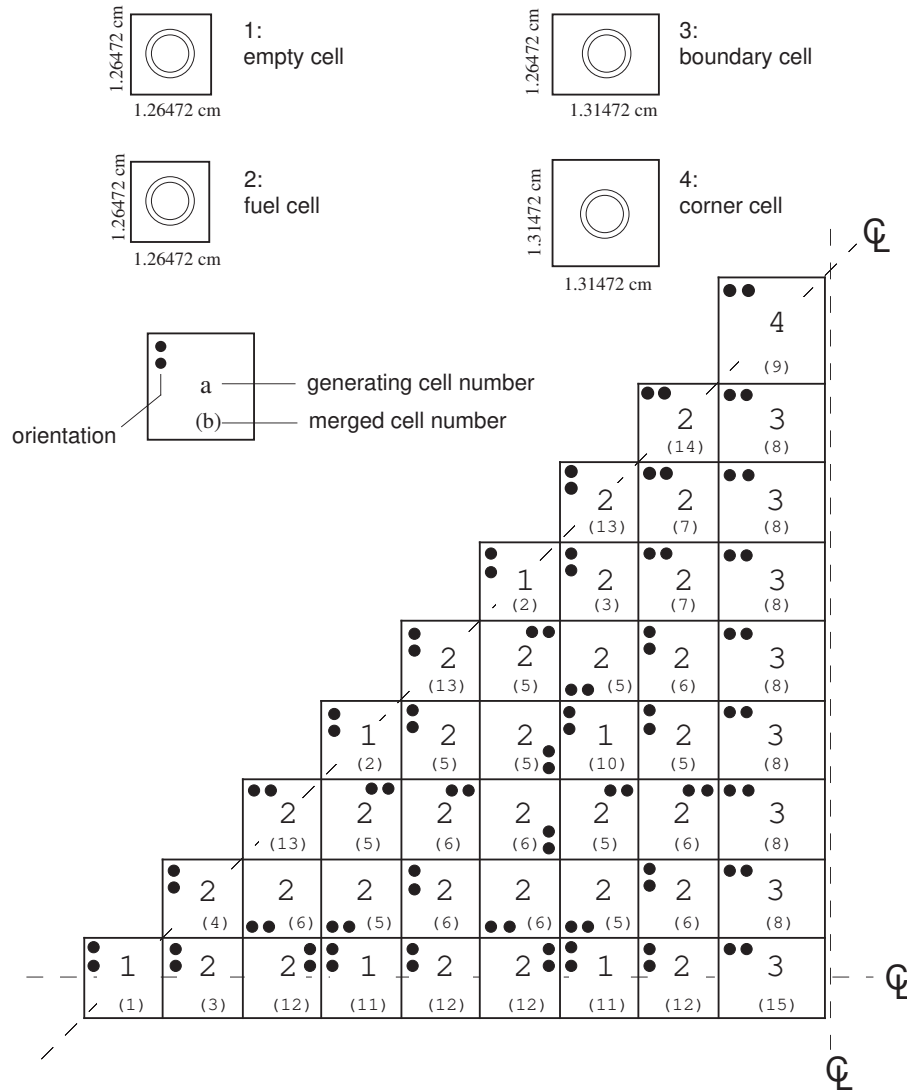

Figure 39: Geometry for test case (TCWU02).

```

*
*-----
* Define STRUCTURES and MODULES used
*-----
LINKED_LIST
  ASSMB DISCR LIBRARY CP CALC OUT DATABASE ISOT SPHGEOM MTRACK ;
SEQ_ASCII
  res ;
MODULE
  LIB: GEO: SYBILT: BIVACT: SHI: ASM: FLU: EDI: COMPO: SPH: DELETE:
  END ;
PROCEDURE asserts ;
*-----
* Microscopic cross sections from file iaea format WIMSD4
*-----
LIBRARY := LIB: ::
  NMIX 8 CTRA WIMS
  
```

```

MIXS LIB: WIMSD4 FIL: iaea
MIX 1 579.9
  H1H20 = '3001' 4.76690E-2 016H20 = '6016' 2.38345E-2
  BNat = '1011' 2.38103E-5
MIX 2 579.9
  Cr52 = '52' 7.54987E-5 016 = '6016' 3.06711E-4
  Zr91 = '91' 4.18621E-2 Fe56 = '2056' 1.47624E-4
MIX 3 579.9
  H1H20 = '3001' 4.65292E-2 016H20 = '6016' 2.32646E-2
  Fe56 = '2056' 4.45845E-5 Cr52 = '52' 4.79927E-5
  Ni58 = '58' 1.13521E-4
  MoNat = '96' 4.03755E-6
  Al27 = '27' 2.35231E-6
  Mn55 = '55' 4.15901E-7
  BNat = '1011' 2.32761E-5
  Zr91 = '91' 8.92427E-4
MIX 4 579.9
  Cr52 = '52' 7.07291E-5 016 = '6016' 2.87335E-4
  Zr91 = '91' 3.92175E-2 Fe56 = '2056' 1.38298E-4
MIX 5 579.9
  H1H20 = '3001' 4.71346E-2 016H20 = '6016' 2.35673E-2
  Fe56 = '2056' 2.09013E-5 Cr52 = '52' 2.24991E-5
  Ni58 = '58' 5.32188E-5
  MoNat = '96' 1.89281E-6
  Al27 = '27' 1.10277E-6
  Mn55 = '55' 1.94976E-7
  BNat = '1011' 2.35598E-5
  Zr91 = '91' 4.18372E-4
MIX 6 579.9
  H1H20 = '3001' 4.71676E-2 016H20 = '6016' 2.35838E-2
  Fe56 = '2056' 1.96130E-5 Cr52 = '52' 2.11122E-5
  Ni58 = '58' 4.99383E-5
  MoNat = '96' 1.77614E-6
  Al27 = '27' 1.03479E-6
  Mn55 = '55' 1.82957E-7
  BNat = '1011' 2.35753E-5
  Zr91 = '91' 3.92583E-4
MIX 7 579.9
  H1H20 = '3001' 4.72020E-2 016H20 = '6016' 2.36010E-2
  Fe56 = '2056' 1.82630E-5 Cr52 = '52' 1.96591E-5
  Ni58 = '58' 4.65011E-5
  MoNat = '96' 1.65389E-6
  Al27 = '27' 9.63569E-7
  Mn55 = '55' 1.70365E-7
  BNat = '1011' 2.35914E-5
  Zr91 = '91' 3.65562E-4
MIX 8 933.6
  U235 = '2235' 7.39237E-4 1 016 = '6016' 4.49355E-2
  U238 = '8238' 2.17285E-2 1

```

```
;
```

```
*----
```

```

* Geometry ASSMB : a 17 X 17 normal PWR assembly
* contains C1 : cell without fuel
*           C2 : normal fuel cell
*           C3 : peripheral cell

```

```

*           C4 : corner cell
*-----
ASSMB := GEO: :: CAR2D 9 9
  X- DIAG X+ REFL Y- SYME Y+ DIAG
  CELL C1 C2 C2 C1 C2 C2 C1 C2 C3
        C2 C2 C2 C2 C2 C2 C2 C3
          C2 C2 C2 C2 C2 C2 C3
            C1 C2 C2 C1 C2 C3
              C2 C2 C2 C2 C3
                C1 C2 C2 C3
                  C2 C2 C3
                    C2 C3
                      C4
MERGE 1  3 12 11 12 12 11 12 15
        4  6  5  6  6  5  6  8
          13 5  6  6  5  6  8
            2  5  5 10  5  8
              13 5  5  6  8
                2  5  7  8
                  13  7  8
                    14  8
                      9
TURN  H  H  B  H  H  B  H  H  A
      H  G  G  H  G  G  H  A
        A  E  E  F  E  E  A
          H  H  F  H  H  A
            H  E  G  H  A
              H  H  A  A
                H  A  A
                  A  A
                    A
::: C1 := GEO: CARCEL 2
  MESHX 0.0 1.26472 MESHY 0.0 1.26472
  RADIUS 0.0 0.572435 0.613142 MIX 1 2 3 ;
::: C2 := GEO: C1 RADIUS 0.0 0.412660 0.474364 MIX 8 4 5 ;
::: C3 := GEO: C2 MESHX 0.0 1.31472 MIX 8 4 6 ;
::: C4 := GEO: C3 MESHY 0.0 1.31472 MIX 8 4 7 ;
;
*-----
* Self-Shielding calculation SYBIL
* Transport calculation SYBIL
* Flux calculation for B1 homogeneous leakage
* Editing using SPH model for transport-diffusion
*-----
DISCR := SYBILT: ASSMB ::
  TITLE 'TCWU02: 17 X 17 MULTICELL PWR BENCHMARK WITHOUT POISON'
  MAXR 400 QUA2 6 3 ;
LIBRARY := SHI: LIBRARY DISCR :: EDIT 0 NOLJ ;
CP := ASM: LIBRARY DISCR ;
CALC := FLU: CP LIBRARY DISCR ::
  TYPE B B1 PNL ;
assertS CALC :: 'K-INFINITY' 1 1.257190 ;

OUT := EDI: LIBRARY DISCR CALC ASSMB ::
  EDIT 3 UPS SAVE MICR RES MERGE CELL COND 4.0

```

```

;
SPHGEO := OUT :: STEP UP 'MACRO-GEOM' ;
MTRACK := BIVACT: SPHGEO :: PRIM 1 2 EDIT 0 ;
OUT := SPH: OUT MTRACK ;
SPHGEO MTRACK := DELETE: SPHGEO MTRACK ;

DATABASE := COMPO: ::
  EDIT 5
  COMM 'Multi-parameter reactor database' ENDC
  INIT
;
DATABASE := COMPO: DATABASE OUT ::
  EDIT 3
;
res := DATABASE ;

ISOT := DATABASE :: STEP UP default
                        STEP UP MIXTURES STEP AT 5
                        STEP UP CALCULATIONS STEP AT 1
                        STEP UP ISOTOPELIST STEP AT 1 ;
assertS ISOT :: 'NWT0' 1 5.186729E-01 ;
assertS ISOT :: 'NWT0' 2 1.305927E-01 ;

ECHO "test TCWU02 completed" ;
END: ;
QUIT "LIST" .

```

### 8.5.3 (TCWU03) – An hexagonal assembly

This test case represents a production calculation of a typical hexagonal control assembly. Its configuration is presented in Figure 40.

Input data for test case: **TCWU03.x2m**

```

*-----
* TEST CASE TCWU03
* MULTICELL HEXAGONAL ASSEMBLY WITH POISON
* iaea WLUP Library
*
* REF: none
*
*-----
* Define STRUCTURES and MODULES used
*-----
LINKED_LIST
  ASSMBH DISCR LIBRARY CP CALC OUT DATABASE ISOT SPHGEO MTRACK ;
SEQ_ASCII
  res ;
MODULE
  GEO: SYBILT: BIVACT: LIB: SHI: ASM: FLU: EDI: COMPO: SPH: DELETE:
  END: ;
PROCEDURE assertS ;
*-----
* Microscopic cross sections from file iaea format WIMSD4

```

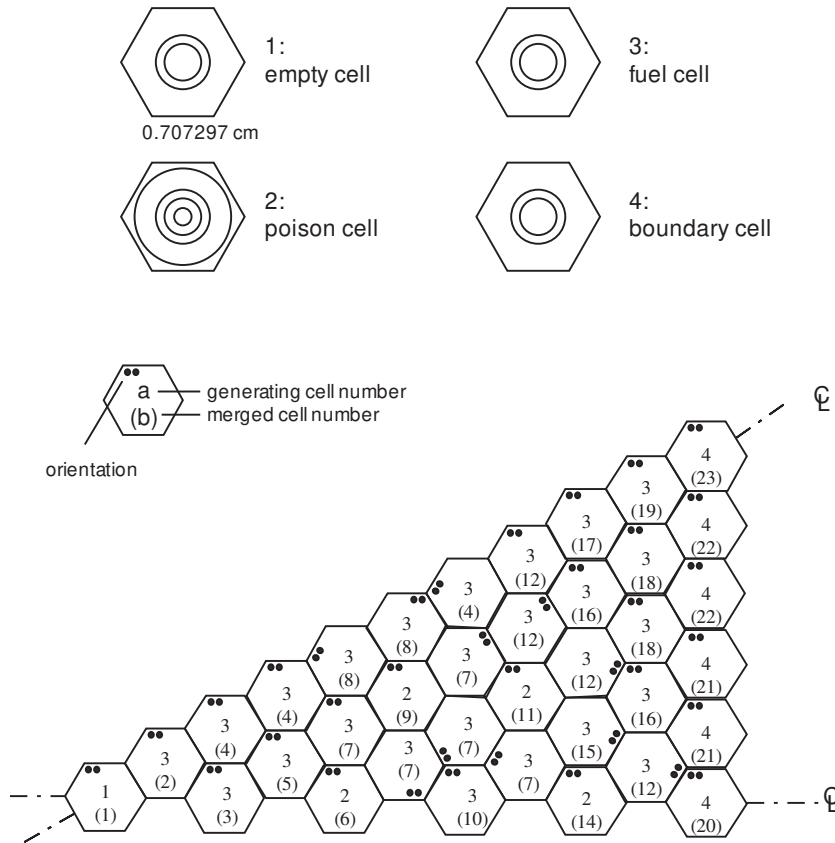

Figure 40: Geometry for test case (TCWU03).

\*-----

```

LIBRARY := LIB: ::
  NMIX 11 CTRA WIMS
  MIXS LIB: WIMSD4 FIL: iaea
  MIX 1 579.9
    H1H20 = '3001' 4.76690E-2 016H20 = '6016' 2.38345E-2
    BNat = '1011' 2.38103E-5
  MIX 2 579.9
    Cr52 = '52' 7.54987E-5 Fe56 = '2056' 1.47624E-4
    Zr91 = '91' 4.18621E-2
  MIX 3 579.9
    H1H20 = '3001' 4.65292E-2 016H20 = '6016' 2.32646E-2
    Cr52 = '52' 4.79927E-5
    Fe56 = '2056' 4.45845E-5 Ni58 = '58' 1.13521E-4
    MoNat = '96' 4.03755E-6
    Al27 = '27' 2.35231E-6
    Mn55 = '55' 4.15901E-7
    BNat = '1011' 2.32761E-5
    Zr91 = '91' 8.92427E-4
  MIX 4 933.6
    U235 = '2235' 7.39237E-4 1 016 = '6016' 4.49355E-2
    U238 = '8238' 2.17285E-2 1
  MIX 5 579.9
    Cd113 = '2113' 2.62493E-3 In115 = '2115' 7.57464E-3
    Ag109 = '3109' 4.49188E-2
  
```



```

MIX 6 579.9
  Fe56 = '2056' 5.57670E-2
  Mn55 = '55' 8.02943E-4
MIX 7 579.9
  H1H20 = '3001' 3.06466E-2
  Fe56 = '2056' 5.27485E-5
  BNat = '1011' 1.53077E-5
  Zr91 = '91' 1.49580E-2
MIX 8 579.9
  H1H20 = '3001' 4.65292E-2
  Fe56 = '2056' 4.45845E-5
  Mn55 = '55' 4.15901E-7
  BNat = '1011' 2.32761E-5
  Zr91 = '91' 8.92427E-4
MIX 9 579.9
  Cr52 = '52' 7.07291E-5
  Zr91 = '91' 3.92175E-2
MIX 10 579.9
  H1H20 = '3001' 4.71346E-2
  Fe56 = '2056' 2.09013E-5
  Mn55 = '55' 1.94976E-7
  Zr91 = '91' 4.18372E-4
MIX 11 579.9
  H1H20 = '3001' 4.71676E-2
  Fe56 = '2056' 1.96130E-5
  Mn55 = '55' 1.82957E-7
  BNat = '1011' 2.35753E-5
  Zr91 = '91' 3.92583E-4
  Cr52 = '52' 1.52702E-2
  Ni58 = '58' 7.51418E-3
  O16H20 = '6016' 1.53233E-2
  Cr52 = '52' 2.69769E-5
  O16H20 = '6016' 2.32646E-2
  Cr52 = '52' 4.79927E-5
  Ni58 = '58' 1.13521E-4
  MoNat = '96' 4.03755E-6
  Al27 = '27' 2.35231E-6
  O16 = '6016' 2.87335E-4
  Fe56 = '2056' 1.38298E-4
  O16H20 = '6016' 2.35673E-2
  Cr52 = '52' 2.24991E-5
  Ni58 = '58' 5.32188E-5
  MoNat = '96' 1.89281E-6
  Al27 = '27' 1.10277E-6
  BNat = '1011' 2.35598E-5
  O16H20 = '6016' 2.35838E-2
  Cr52 = '52' 2.11122E-5
  Ni58 = '58' 4.99383E-5
  MoNat = '96' 1.77614E-6
  Al27 = '27' 1.03479E-6

```

```

;
*-----
* Geometry ASSMBH : hexagonal assembly with poison
* contains C1 : cell without fuel
*           C2 : poison cell
*           C3 : normal fuel cell
*           C4 : peripheral cell
*-----

```

```

ASSMBH := GEO: :: HEX 36
HBC S30 REFL
CELL C1 C3 C3 C3 C3 C3 C2 C3 C3 C3 C2 C3 C3 C3 C3 C3 C2
      C3 C3 C2 C3 C3 C3 C3 C3 C3 C3 C3 C3 C4 C4 C4 C4 C4
TURN  A  A  A  A  A  A  A  A  B  D  A  I  A  C  F  J  B  A
      F  A  A  E  E  A  A  E  A  A  A  A  A  A  A  A  A  A
MERGE 1  2  3  4  5  4  6  7  8  7  9  8  10  7  7  4  7  11
      12 13 14 15 12 16 17 12 16 18 18 19 20 21 21 22 22 23
::: C1 := GEO: HEXCEL 2
SIDE 0.707297 RADIUS 0.0 0.412282 0.475917

```

```

MIX 1 2 3 ;
::: C2 := GEO: HEXCEL 5
SIDE 0.707297 RADIUS 0.0 0.25057 0.354359 0.436 0.486 0.6125
MIX 5 5 5 6 7 8 ;
::: C3 := GEO: C1 MIX 4 9 10 ;
::: C4 := GEO: C3 MIX 4 9 11 ;
;
*-----
* Self-Shielding calculation JPM
* Transport calculation SYBIL
* Flux calculation for B1 homogeneous leakage
* Editing using SPH model for transport-diffusion
*-----
DISCR := SYBILT: ASSMBH ::
TITLE 'TCWU03: MULTICELL HEXAGONAL ASSEMBLY WITH POISON'
MAXR 400 MAXZ 15000 QUA2 6 3 ;
LIBRARY := SHI: LIBRARY DISCR :: EDIT 0 NOLJ ;
CP := ASM: LIBRARY DISCR ;
CALC := FLU: CP LIBRARY DISCR ::
TYPE B B1 PNL ;
assertS CALC :: 'K-INFINITY' 1 0.7116683 ;
OUT := EDI: LIBRARY DISCR CALC ASSMBH ::
EDIT 3 UPS SAVE MICR RES MERGE CELL COND 4.0
;
SPHGEOM := OUT :: STEP UP 'MACRO-GEOM' ;
SPHGEOM := GEO: SPHGEOM :: SPLITH 0 ;
MTRACK := BIVACT: SPHGEOM :: PRIM 1 2 ;
OUT := SPH: OUT MTRACK ;
SPHGEOM MTRACK := DELETE: SPHGEOM MTRACK ;

DATABASE := COMPO: ::
EDIT 5
COMM 'Multi-parameter reactor database' ENDC
INIT
;
DATABASE := COMPO: DATABASE OUT ::
EDIT 3
;
res := DATABASE ;

ISOT := DATABASE :: STEP UP default
STEP UP MIXTURES STEP AT 5
STEP UP CALCULATIONS STEP AT 1
STEP UP ISOTOPESLIST STEP AT 1 ;
assertS ISOT :: 'NWT0' 1 1.442307E+00 ;
assertS ISOT :: 'NWT0' 2 1.477404E-01 ;

ECHO "test TCWU03 completed" ;
END: ;
QUIT "LIST" .

```

#### 8.5.4 (TCWU04) – A Cylindrical cell with burnup.

This test case represents a burnup calculation for the mosteller annular geometry.

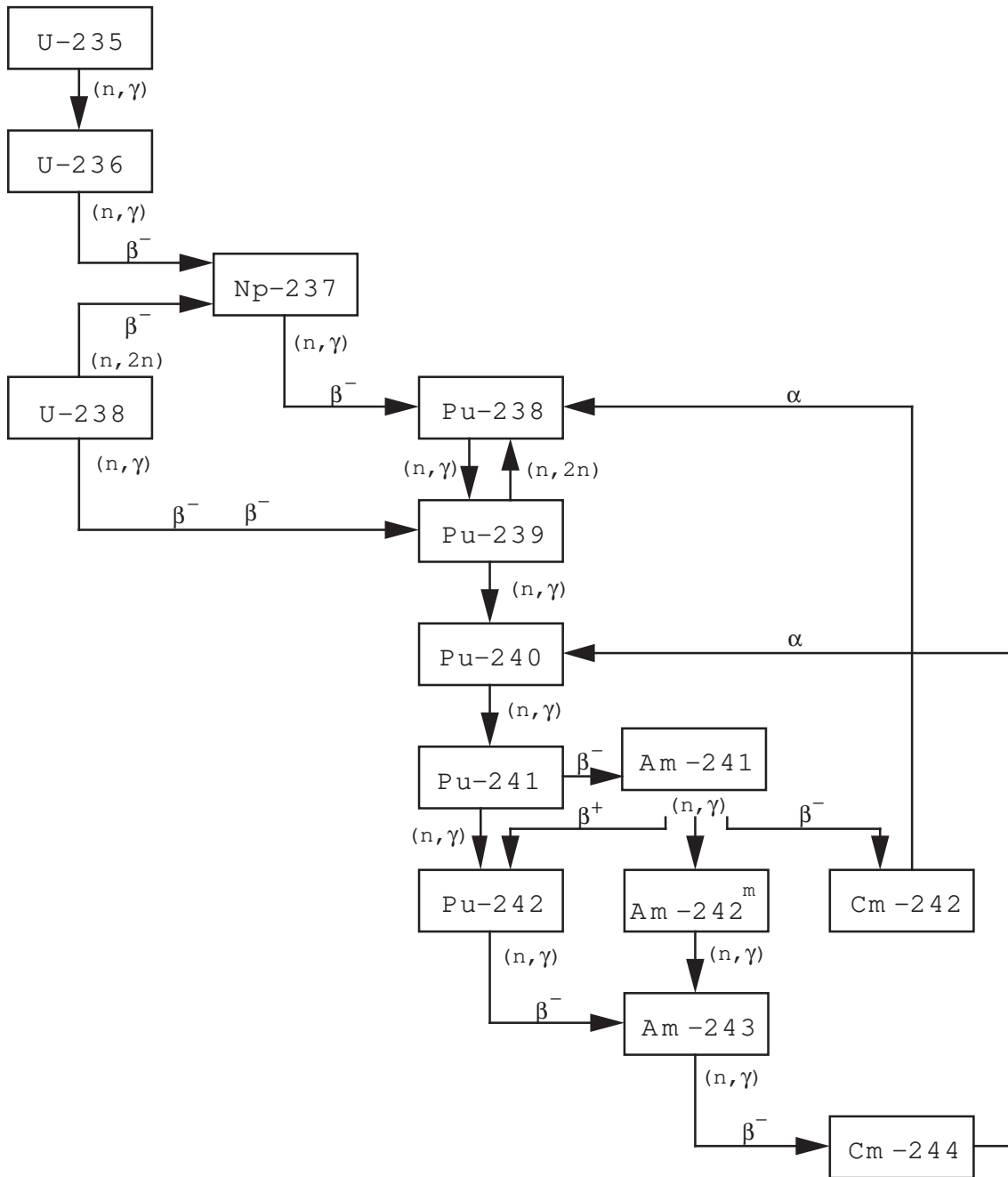

Figure 41: Depletion chain of heavy isotopes.

Input data for test case: **TCWU04.x2m**

```

*-----
* TEST CASE TCWU04
* iaea WLUP Library
* ANNULAR MOSTELLER BENCHMARK WITH BURNUP
*
* REF: R. Mosteller et al. Nucl. Sci. Eng. 107, 265 (1991)
*
*-----
    
```

```

* Define variables
*-----
INTEGER
  istep := 1 ;
REAL
  evobeg evoend ;
REAL
  step2 step3 step4 step5 step6 step7 :=
  1.0 27.1739 47.5544 67.9348 101.9022 135.8696 ;
*-----
* Define STRUCTURES and MODULES used
*-----
PARAMETER res :: :: SEQ_ASCII res ;
LINKED_LIST
  LIBRARY MOSTELAS MOSTELA TRACKS TRACK SYS FLUX BURNUP EDITION
  DATABASE ISOT ;
MODULE
  GEO: SYBILT: LIB: SHI: ASM: FLU: EVO: EDI: COMPO: DELETE: END: ;
PROCEDURE asserts ;
*-----
* Depletion data from file iaea format WIMSD4
* Microscopic cross sections from file iaea format WIMSD4
*-----
LIBRARY := LIB: ::
  NMIX 3 CTRA WIMS
  DEPL LIB: WIMSD4 FIL: iaea
  MIXS LIB: WIMSD4 FIL: iaea
  MIX 1 600.0
    U235 = '2235' 1.66078E-4 1
    U238 = '8238' 2.28994E-2 1
    U236 = '236' 0.0 1
    Pu239 = '6239' 0.0 1
  MIX 2 600.0
    Zr91 = '91' 3.83243E-2
  MIX 3 600.0
    H1H20 = '3001' 4.42326E-2 016H20 = '6016' 2.21163E-2
    BNat = '1011' 1.02133E-5
  ;
*-----
* Geometry MOSTELAS : 3 regions annular cell for self-shielding
* MOSTELA : 4 regions annular cell for transport
*-----
MOSTELAS := GEO: :: TUBE 3
  R+ REFL RADIUS 0.0 0.39306 0.45802 0.71206
  MIX 1 2 3 ;
MOSTELA := GEO: MOSTELAS ::
  SPLITR 2 1 1 ;
*-----
* Create the reactor database
*-----
DATABASE := COMPO: ::
  EDIT 5
  COMM 'Multi-parameter reactor database' ENDC
  PARA 'BURN' IRRA
  PARA 'FLUB' FLUB

```

```

INIT
;
*-----
* Self-Shielding calculation SYBIL
* Transport calculation      SYBIL
* Flux calculation for keff with imposed buckling
* using B1 homogeneous leakage model
*-----
TRACKS := SYBILT: MOSTELAS ::
  TITLE 'TCWU04: MOSTELLER BENCHMARK WITH BURNUP'
  EDIT 1 MAXR 3 ;
LIBRARY := SHI: LIBRARY TRACKS :: EDIT 0 NOLJ ;
TRACK := SYBILT: MOSTELA ::
  TITLE 'TCWU04: MOSTELLER BENCHMARK WITH BURNUP'
  EDIT 1 MAXR 4 ;
SYS := ASM: LIBRARY TRACK ;
FLUX := FLU: SYS LIBRARY TRACK ::
  TYPE K B1 PNL BUCK 0.2948E-2 ;
EDITION := EDI: LIBRARY TRACK FLUX ::
  EDIT 3 MICR RES MERG COMP COND 4.0 SAVE ;
*-----
* Burnup loop: for first step BURNUP is created
* while for other steps it is modified
* two burnup per step:
* 1) get a first approximation of final composition followed
*    by a transport calculation
* 2) use approximation for final flux distribution to get a
*    better approximation for final composition
*-----
EVALUATE evoend := 0.0 ;
WHILE evoend step2 < DO
  EVALUATE evobeg := evoend ;
  EVALUATE evoend := step2 ;
  IF istep 1 = THEN
    BURNUP LIBRARY := EVO: LIBRARY FLUX TRACK ::
      SAVE <<evobeg>> DAY POWR 36.8
      DEPL <<evobeg>> <<evoend>> DAY POWR 36.8
      SET <<evoend>> DAY ;
  ELSE
    BURNUP LIBRARY := EVO: BURNUP LIBRARY FLUX TRACK ::
      SAVE <<evobeg>> DAY POWR 36.8
      NOEX DEPL <<evobeg>> <<evoend>> DAY POWR 36.8
      SET <<evoend>> DAY ;
  ENDIF ;
LIBRARY := SHI: LIBRARY TRACKS :: EDIT 0 NOLJ ;
SYS := DELETE: SYS ;
SYS := ASM: LIBRARY TRACK ;
FLUX := FLU: FLUX SYS LIBRARY TRACK ::
  TYPE K B1 PNL BUCK 0.2948E-2 ;

BURNUP LIBRARY := EVO: BURNUP LIBRARY FLUX TRACK ::
  SAVE <<evoend>> DAY POWR 36.8
  DEPL <<evobeg>> <<evoend>> DAY POWR 36.8
  SET <<evoend>> DAY ;
LIBRARY := SHI: LIBRARY TRACKS :: EDIT 0 NOLJ ;

```

```

SYS := DELETE: SYS ;
SYS := ASM: LIBRARY TRACK ;
FLUX := FLU: FLUX SYS LIBRARY TRACK ::
    TYPE K B1 PNL BUCK 0.2948E-2 ;

EDITION := EDI: EDITION LIBRARY TRACK FLUX ::
    EDIT 3 SAVE ;
BURNUP LIBRARY := EVO: BURNUP LIBRARY FLUX TRACK ::
    SAVE <<evoend>> DAY POWR 36.8 ;
DATABASE := COMPO: DATABASE EDITION BURNUP ::
    EDIT 3
    SET <<evoend>> DAY
    ;
EVALUATE step2 step3 step4 step5 step6 step7 :=
    step3 step4 step5 step6 step7 step2 ;
EVALUATE istep := istep 1 + ;
ENDWHILE ;
assertS FLUX :: 'K-EFFECTIVE' 1 0.7332095 ;

res := DATABASE ;

ISOT := DATABASE :: STEP UP default
        STEP UP MIXTURES STEP AT 1
        STEP UP CALCULATIONS STEP AT 2
        STEP UP ISOTOPELIST STEP AT 1 ;
assertS ISOT :: 'NWT0' 1 3.838717E+01 ;
assertS ISOT :: 'NWT0' 2 1.695042E+01 ;

ECHO "test TCWU04 completed" ;
END: ;
QUIT "LIST" .

```

### 8.5.5 (TCWU05) – A CANDU-6 type annular cell with burnup.

This test case represents the typical CANDU type cell with an annular moderator region defined in Figure 42. Both its cross section and depletion data are taken from the same WIMSD4 file. Depletion calculations are performed for 50 day at a fixed power.<sup>[29]</sup> The MICROLIB is defined by the procedure TCWU05Lib.c2m presented in Section 8.5.19.

Input data for test case: **TCWU05.x2m**

```

*-----
* TEST CASE TCWU05
* CANDU-6 ANNULAR CELL
* iaea WLUP Library
* POWER (KW)           = 615.00000
* BURN POWER (KW/KG)  = 31.97130
* URANIUM MASS         = 19.23600
* UO2 REAL DENSITY     = 10.59300
* UO2 EFF DENSITY      = 10.43750
* UO2 TEMPERATURE     = 941.28998
* ENRICHMENT           = 0.71140
* COOLANT D2 AT %     = 99.222
* MODERATOR D2 AT %   = 99.911

```

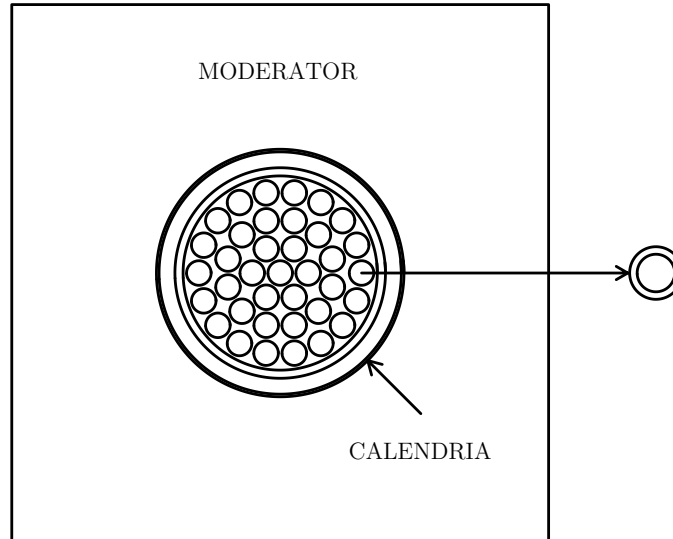

Figure 42: Geometry of the CANDU-6 cell.

```

* NUMBER OF DAYS      = 50
*
*-----
* Define variables and initialize
*   Burnup paremeters
*   a) Power
*     = 31.9713 kw/kg for 0.0 to 300.0 days
*   b) Burnup time interval Delt
*     = 1 day for 0 to 1 day
*     = 4 days for 1 to 5 days
*     = 5 days for 5 to 10 days
*     = 10 days for 10 to 50 days
*     = 20 days for 50 to 150 days
*     = 50 days for 150 to 300 days
*   c) Days with burnup interval changes
*     = 1.0, 5.0, 10.0, 50.0, 150.0 and 300.0 days
*   d) Burnup control time variables Timei, Timef
*     Timei = initial time
*     Timef = final time
*-----
REAL
  Power    Delt Timec Timei Timef :=
  31.9713  1.0  1.0  0.0  0.0 ;
*-----
* Define STRUCTURES and MODULES used
*-----
LINKED_LIST
  LIBRARY CANDU6S CANDU6F VOLMATS VOLMATF PIJ FLUX BURNUP EDITION
  DATABASE ISOT ;
SEQ_BINARY
  INTLINS INTLINF ;
SEQ_ASCII
  database ;
MODULE

```

```

GEO: EXCELT: SHI: ASM: FLU: EVO: EDI: COMPO: DELETE: END: ;
PROCEDURE asserts ;
*-----
* Depletion data from file iaea format WIMSD4
* Microscopic cross sections from file iaea format WIMSD4
*-----
PROCEDURE TCWU05Lib ;
INTEGER   iedit := 1 ;
LIBRARY := TCWU05Lib :: <<iedit>> ;
*-----
* Geometry CANDU6S : 13 regions annular cluster for self-shielding
*           CANDU6F : 31 regions annular cluster for transport
*-----
CANDU6S := GEO: :: TUBE 5
R+ REFL RADIUS  0.00000 5.16890 5.60320  6.44780 6.58750 16.12171
MIX  1 2 3 4 5
CLUSTER ROD1 ROD2 ROD3 ROD4
::: ROD1 := GEO: TUBE 2 MIX 6 10 NPIN  1 RPIN 0.0000 APIN 0.0000
RADIUS 0.00000 0.6122 0.6540 ;
::: ROD2 := GEO: ROD1  MIX 7 10 NPIN  6 RPIN 1.4885 APIN 0.0000 ;
::: ROD3 := GEO: ROD1  MIX 8 10 NPIN 12 RPIN 2.8755 APIN 0.261799 ;
::: ROD4 := GEO: ROD1  MIX 9 10 NPIN 18 RPIN 4.3305 APIN 0.0 ;
;
CANDU6F := GEO: CANDU6S :: SPLITR  6 1 1 1 10
::: ROD1 := GEO: ROD1 SPLITR 2 1 ;
::: ROD2 := GEO: ROD2 SPLITR 2 1 ;
::: ROD3 := GEO: ROD3 SPLITR 2 1 ;
::: ROD4 := GEO: ROD4 SPLITR 2 1 ;
;
*-----
* Create the reactor database
*-----
DATABASE := COMPO: ::
EDIT 5
STEP UP 'moderator'
COMM 'Multi-parameter reactor database for moderator' ENDC
INIT
STEP UP 'fuel'
COMM 'Multi-parameter reactor database for fuel' ENDC
PARA 'BURN' IRRA
PARA 'FLUB' FLUB
INIT
;
*-----
* Self-Shielding calculation EXCEL
* Transport calculation EXCEL
* Flux calculation for keff
*-----
VOLMATS INTLINS := EXCELT: CANDU6S ::
TITLE 'TCWU05: CANDU-6 ANNULAR POWER= 31.971 FUEL TEMP= 941.29'
EDIT 0 MAXR 13 TRAK TISO 5 10.0 SYMM 12 ;
LIBRARY := SHI: LIBRARY VOLMATS INTLINS :: EDIT 0 NOLJ ;
VOLMATF INTLINF := EXCELT: CANDU6F ::
TITLE 'TCWU05: CANDU-6 ANNULAR POWER= 31.971 FUEL TEMP= 941.29'
EDIT 0 MAXR 31 TRAK TISO 5 10.0 SYMM 12 ;

```



```

PIJ := ASM: LIBRARY VOLMATF INTLINF ;
FLUX := FLU: PIJ LIBRARY VOLMATF ::
  TYPE K ;
assertS FLUX :: 'K-INFINITY' 1 1.121034 ;
EDITION := EDI: LIBRARY VOLMATF FLUX ::
  COND 4.0 MERGE MIX 0 0 0 0 1 0 0 0 0 MICR RES SAVE ON 'moderator' ;
DATABASE := COMPO: DATABASE EDITION ::
  EDIT 3
  STEP UP *
  ;
EDITION := EDI: EDITION LIBRARY VOLMATF FLUX ::
  COND 4.0 MERGE COMP MICR 1 Xe135 SAVE ON 'fuel' ;
*-----
* Burnup loop: for first step BURNUP is created
* while for other steps it is modified
*-----
WHILE Timei Timec < DO
  EVALUATE Timef := Timei Delt + ;
  IF Timei 0.0 = THEN
    BURNUP LIBRARY := EVO: LIBRARY FLUX VOLMATF ::
      DEPL <<Timei>> <<Timef>> DAY POWR <<Power>> ;
  ELSE
    BURNUP LIBRARY := EVO: BURNUP LIBRARY FLUX VOLMATF ::
      NOEX DEPL <<Timei>> <<Timef>> DAY POWR <<Power>> ;
  ENDIF ;
LIBRARY := SHI: LIBRARY VOLMATS INTLINS :: EDIT 0 NOLJ ;
PIJ := DELETE: PIJ ;
PIJ := ASM: LIBRARY VOLMATF INTLINF ;
FLUX := FLU: FLUX PIJ LIBRARY VOLMATF ::
  TYPE K ;
EDITION := EDI: EDITION LIBRARY VOLMATF FLUX ::
  SAVE ON 'fuel' ;
BURNUP LIBRARY := EVO: BURNUP LIBRARY FLUX VOLMATF ::
  SAVE <<Timef>> DAY POWR <<Power>> ;
DATABASE := COMPO: DATABASE EDITION BURNUP LIBRARY ::
  EDIT 3
  STEP UP *
  SET <<Timef>> DAY
  ;
*-----
* change delta t for burnup and final time if required
*-----
IF Timef Timec = THEN
  IF Timec 150.0 = THEN
    EVALUATE Delt Timec := 50.0 300.0 ;
  ENDIF ;
  IF Timec 50.0 = THEN
    EVALUATE Delt Timec := 20.0 150.0 ;
  ENDIF ;
  IF Timec 10.0 = THEN
    EVALUATE Delt Timec := 10.0 50.0 ;
  ENDIF ;
  IF Timec 5.0 = THEN
    EVALUATE Delt Timec := 5.0 10.0 ;
  ENDIF ;

```

```

        IF Timec 1.0 = THEN
            EVALUATE Delt Timec := 4.0 5.0 ;
        ENDIF ;
    ENDIF ;
    EVALUATE Timei := Timef ;
ENDWHILE ;
assertS FLUX :: 'K-INFINITY' 1 0.9539985 ;
*-----
*   Export and access the database
*-----
database := DATABASE ;

ISOT := DATABASE :: STEP UP fuel
                STEP UP MIXTURES STEP AT 1
                STEP UP CALCULATIONS STEP AT 5
                STEP UP ISOTOPELIST STEP AT 1 ;
assertS ISOT :: 'NWT0' 1 9.724794E+00 ;
assertS ISOT :: 'NWT0' 2 2.582013E+01 ;
ISOT := DELETE: ISOT ;

ISOT := DATABASE :: STEP UP moderator
                STEP UP MIXTURES STEP AT 1
                STEP UP CALCULATIONS STEP AT 1
                STEP UP ISOTOPELIST STEP AT 1 ;
assertS ISOT :: 'NWT0' 1 9.327801E-02 ;
assertS ISOT :: 'NWT0' 2 3.186788E-01 ;

INTLINF INTLINS := DELETE: INTLINF INTLINS ;
ECHO "test TCWU05 completed" ;
END: ;
QUIT "LIST" .

```

### 8.5.6 (TCWU06) – A CANDU-6 type supercell with control rods.

This test case treats both the CANDU cell with a cartesian moderator region (similar to the cell described in defined Figure 42) and the supercell containing a stainless steel rod which can be either in the inserted or extracted position (see Figure 36). Two groups incremental cross sections corresponding to the rod in the inserted and extracted position with respect to the original supercell containing only 3-D fuel elements are computed.<sup>[29]</sup> The MICROLIB is defined by the procedure TCWU05Lib.c2m presented in Section 8.5.19.

Input data for test case: **TCWU06.x2m**

```

*-----
*   TEST CASE TCWU06
*   CANDU-6 CARTESIAN CELL
*   iaea WLUP Library
*   STAINLESS STELL RODS IN 3D SUPERCELL
*
*   REF: R. Roy et al.  Ann. Nucl. Energy 21, 115 (1994)
*
*-----
*   Define STRUCTURES and MODULES used
*-----

```

```

LINKED_LIST
  LIBRARY LIBRARY2 CANDU6F CANDU6S TRACK SYS FLUX EDITION BCO BCI
  SSRODS ;
SEQ_BINARY
  INTLIN ;
MODULE
  GEO: EXCELT: LIB: SHI: ASM: FLU: EDI: DELETE: END: ;
PROCEDURE asserts ;
*-----
* Depletion data from file iaea format WIMSD4
* Microscopic cross sections from file iaea format WIMSD4
*-----
PROCEDURE TCWU05Lib ;
INTEGER   iedit := 1 ;
LIBRARY := TCWU05Lib :: <<iedit>> ;
*-----
* CELL CALCULATION
* Geometry CANDU6S : 14 regions Cartesian cluster for self-shielding
*   CANDU6F : 32 regions Cartesian cluster for transport
*   BCO      : 48 regions 3D Cartesian geometry
*   BCI      : 48 regions 3D Cartesian geometry
*-----
CANDU6S := GEO: :: CARCEL 5
  X+ REFL X- REFL MESHX -14.2875 14.2875
  Y+ REFL Y- REFL MESHY -14.2875 14.2875
  RADIUS 0.00000 5.16890 5.60320 6.44780 6.58750 14.00
  MIX 1 2 3 4 5 5
  CLUSTER ROD1 ROD2 ROD3 ROD4
  ::: ROD1 := GEO: TUBE 2 MIX 6 10 NPIN 1 RPIN 0.0000 APIN 0.0000
    RADIUS 0.00000 0.6122 0.6540 ;
  ::: ROD2 := GEO: ROD1 MIX 7 10 NPIN 6 RPIN 1.4885 APIN 0.0000 ;
  ::: ROD3 := GEO: ROD1 MIX 8 10 NPIN 12 RPIN 2.8755 APIN 0.261799 ;
  ::: ROD4 := GEO: ROD1 MIX 9 10 NPIN 18 RPIN 4.3305 APIN 0.0 ;
;
CANDU6F := GEO: CANDU6S :: SPLITR 6 1 1 1 10
  ::: ROD1 := GEO: ROD1 SPLITR 2 1 ;
  ::: ROD2 := GEO: ROD2 SPLITR 2 1 ;
  ::: ROD3 := GEO: ROD3 SPLITR 2 1 ;
  ::: ROD4 := GEO: ROD4 SPLITR 2 1 ;
;
*-----
* Self-Shielding calculation EXCEL
* Transport calculation EXCEL
* Flux calculation for keff
*-----
TRACK INTLIN := EXCELT: CANDU6S ::
  TITLE 'TCWU06: CANDU-6 CARTESIAN FUEL TEMP= 941.29'
  EDIT 0 MAXR 14 TRAK TISO 29 20.0 SYMM 4 ;
LIBRARY := SHI: LIBRARY TRACK INTLIN :: EDIT 0 NOLJ ;
TRACK INTLIN := DELETE: TRACK INTLIN ;
TRACK INTLIN := EXCELT: CANDU6F ::
  TITLE 'TCWU06: CANDU-6 CARTESIAN FUEL TEMP= 941.29'
  EDIT 0 MAXR 32 TRAK TISO 29 20.0 SYMM 4 ;
SYS := ASM: LIBRARY TRACK INTLIN ::
  EDIT 0 ;

```

```

FLUX := FLU: SYS LIBRARY TRACK ::
  TYPE K ;
assertS FLUX :: 'K-EFFECTIVE' 1 1.120661 ;
*-----
* Microscopic cross sections from WIMSLIB for stainless steel
* MIX 1,2,3 from EDI: : fuel, structure material and moderator
* MIX 4 stainless steel rods
*-----
EDITION := EDI: LIBRARY TRACK FLUX ::
  EDIT 0 MERGE MIX 1 2 2 2 3 1 1 1 1 1 SAVE ON SSRODS ;
SSRODS := EDITION :: STEP UP SSRODS ;
LIBRARY2 := LIB: SSRODS ::
  EDIT 0 NMIX 4 CTRA WIMS
  MIXS LIB: WIMSD4 FIL: iaea
  MIX 4      345.66              Fe56      = '2056'    6.19027E-2
    Cr52      = '52'            1.56659E-3 Ni58      = '58'      6.83337E-3
    Si29      = '29'            7.79072E-4 C12       = '2012'   1.46552E-4
    Mn55      = '55'            1.25431E-3
  ;
EDITION TRACK INTLIN SYS FLUX := DELETE:
  EDITION TRACK INTLIN SYS FLUX ;
*-----
* SUPERCELL CALCULATION
* Geometry BCO      : 27 regions 3D Cartesian geometry with rods out
*                   BCI      : 27 regions 3D Cartesian geometry with rods in
*-----
BCO := GEO: :: CAR3D 3 2 2
  X- REFL X+ SYME Y- REFL Y+ SYME Z- REFL Z+ SYME
  CELL M  MX MX MX FXY MXY M  MX BX MX FXY BXY
  TURN A  A  A  F  A  A  A  A  A  F  A  A
  ::: M := GEO: CAR3D 1 1 1 MIX 3
    MESHX 0.0 7.14375
    MESHY 0.0 7.14375
    MESHZ -8.25500 8.25500 SPLITZ 2 ;
  ::: MX := GEO: M MESHX -7.14375 +7.14375 SPLITX 2 ;
  ::: MXY := GEO: MX MESHY -7.14375 +7.14375 SPLITY 2 ;
  ::: BX := GEO: CARCELY 2 1 MIX 3 3 3
    MESHX -7.14375 7.14375 SPLITX 2
    MESHY 0.0 7.14375
    MESHZ -8.25500 8.25500 SPLITZ 2
    RADIUS 0.0 3.5100 3.8100 ;
  ::: BXY := GEO: BX MESHY -7.14375 +7.14375 SPLITY 2 ;
  ::: FXY := GEO: CARCELZ 2 1 MIX 1 2 3
    MESHX -7.14375 7.14375 SPLITX 2
    MESHY -7.14375 7.14375 SPLITY 2
    MESHZ -8.25500 8.25500 SPLITZ 2
    RADIUS 0.0 5.16890 6.58750 ;
  ;
BCI := GEO: BCO ::
  ::: BX := GEO: BX MIX 3 4 3 ;
  ::: BXY := GEO: BXY MIX 3 4 3 ;
  ;
*-----
* Transport calculation      EXCEL
* Flux calculation for keff

```

```

* Homogenized properties for rod out
*-----
TRACK INTLIN := EXCELT: BCO ::
  EDIT 0 MAXR 40 TRAK TISO 2 1.0 ;
SYS := ASM: LIBRARY2 TRACK INTLIN ::
  EDIT 0 ;
FLUX := FLU: SYS LIBRARY2 TRACK ::
  TYPE K ;
assertS FLUX :: 'K-EFFECTIVE' 1 1.127695 ;
EDITION := EDI: LIBRARY2 TRACK FLUX ::
  EDIT 2 MERG COMP COND 4.0 SAVE ON 'NOBC' ;
SYS TRACK INTLIN := DELETE: SYS TRACK INTLIN ;
*-----
* Transport calculation      EXCEL
* Flux calculation for keff
* Homogenized properties for rod in
*-----
TRACK INTLIN := EXCELT: BCI ::
  EDIT 0 MAXR 40 TRAK TISO 2 1.0 ;
SYS := ASM: LIBRARY2 TRACK INTLIN ::
  EDIT 0 ;
FLUX := FLU: FLUX SYS LIBRARY2 TRACK ::
  TYPE K ;
assertS FLUX :: 'K-EFFECTIVE' 1 1.042922 ;
EDITION := EDI: EDITION LIBRARY2 TRACK FLUX ::
  EDIT 2 MERG COMP COND 4.0 STAT DELS REFE 'NOBC' ;
TRACK INTLIN SYS := DELETE: TRACK INTLIN SYS ;
ECHO "test TCWU06 completed" ;
END: ;
QUIT "LIST" .

```

### 8.5.7 (TCWU07) – A CANDU-6 type calculation using various leakage options.

This test case treats the CANDU cell with a cartesian moderator region (similar to the cell described in defined Figure 42) using various leakage options. The MICROLIB is defined by the procedure TCWU05Lib.c2m presented in Section 8.5.19.

Input data for test case: **TCWU07.x2m**

```

*-----
* TEST CASE TCWU07
* CANDU-6 CARTESIAN CELL
* iaea WLUP Library
* TEST VARIOUS LEAKAGE OPTIONS
*
*-----
* Define STRUCTURES and MODULES used
*-----
LINKED_LIST
  LIBRARY CANDU6S CANDU6T CANDU6SV CANDU6TV TRACK
  SYS FLUX EDITION ;
MODULE
  GEO: EXCELT: LIB: SHI: ASM: FLU: EDI: DELETE: END: ;
SEQ_BINARY

```

```

      INTLIN ;
PROCEDURE asserts ;
*-----
* Depletion data from file iaea format WIMSD4
* Microscopic cross sections from file iaea format WIMSD4
*-----
PROCEDURE TCWU05Lib ;
INTEGER   iedit := 1 ;
LIBRARY := TCWU05Lib :: <<iedit>> ;
*-----
* Geometry CANDU6S : GEOMETRY FOR SELF-SHIELDING (NO VOID)
*           CANDU6F : GEOMETRY FOR TRANSPORT      (NO VOID)
*           CANDU6FV: GEOMETRY FOR TRANSPORT      (COOLANT VOID)
*           CANDU6FV: GEOMETRY FOR TRANSPORT      (COOLANT VOID)
*-----
CANDU6S := GEO: :: CARCEL 5
  X+ REFL X- REFL MESHX -14.2875 14.2875
  Y+ REFL Y- REFL MESHY -14.2875 14.2875
  RADIUS 0.00000 5.16890 5.60320 6.44780 6.58750 14.00
  MIX    1      2      3      4      5      5
  CLUSTER ROD1 ROD2 ROD3 ROD4
  ::: ROD1 := GEO: TUBE 2 MIX 6 10 NPIN 1 RPIN 0.0000 APIN 0.0000
    RADIUS 0.00000 0.6122 0.6540 ;
  ::: ROD2 := GEO: ROD1 MIX 7 10 NPIN 6 RPIN 1.4885 APIN 0.0000 ;
  ::: ROD3 := GEO: ROD1 MIX 8 10 NPIN 12 RPIN 2.8755 APIN 0.261799 ;
  ::: ROD4 := GEO: ROD1 MIX 9 10 NPIN 18 RPIN 4.3305 APIN 0.0 ;
;
CANDU6T := GEO: CANDU6S :: SPLITR 6 1 1 1 10
  ::: ROD1 := GEO: ROD1 SPLITR 2 1 ;
  ::: ROD2 := GEO: ROD2 SPLITR 2 1 ;
  ::: ROD3 := GEO: ROD3 SPLITR 2 1 ;
  ::: ROD4 := GEO: ROD4 SPLITR 2 1 ;
;
CANDU6SV := GEO: CANDU6S :: MIX 0 2 3 4 5 5 ;
CANDU6TV := GEO: CANDU6SV :: SPLITR 6 1 1 1 10
  ::: ROD1 := GEO: ROD1 SPLITR 2 1 ;
  ::: ROD2 := GEO: ROD2 SPLITR 2 1 ;
  ::: ROD3 := GEO: ROD3 SPLITR 2 1 ;
  ::: ROD4 := GEO: ROD4 SPLITR 2 1 ;
;
*-----
* CASE WITH NO VOID
* Self-Shielding calculation EXCEL
* Transport calculation EXCEL
* Flux TYPE K AND B WITH VARIOUS LEAKAGE OPTIONS
*-----
TRACK INTLIN := EXCELT: CANDU6S ::
  TITLE 'TCWU07: CANDU-6 CARTESIAN FUEL TEMP= 941.29'
  EDIT 0 MAXR 14 TRAK TISO 7 20.0 SYMM 4 ;
LIBRARY := SHI: LIBRARY TRACK INTLIN :: EDIT 0 NOLJ ;
TRACK INTLIN := DELETE: TRACK INTLIN ;
TRACK INTLIN := EXCELT: CANDU6T ::
  TITLE 'TCWU07: CANDU-6 CARTESIAN FUEL TEMP= 941.29'
  EDIT 0 MAXR 32 ANIS 2 TRAK TISO 7 20.0 SYMM 4 ;
SYS := ASM: LIBRARY TRACK INTLIN ::

```

```

EDIT 0 PIJK ;
FLUX := FLU: SYS LIBRARY TRACK ::
  TYPE K ;
assertS FLUX :: 'K-EFFECTIVE' 1 1.120623 ;
EDITION := EDI: LIBRARY TRACK FLUX ::
  EDIT 3 SAVE COND 4.0 TAKE REGI 1 4 7 10 16 24 ;
FLUX := FLU: FLUX SYS LIBRARY TRACK ::
  TYPE B B1 PNL ;
assertS FLUX :: 'K-INFINITY' 1 1.112290 ;
EDITION := EDI: EDITION LIBRARY TRACK FLUX ::
  EDIT 3 SAVE COND 4.0 TAKE REGI 1 4 7 10 16 24 ;
FLUX := FLU: FLUX SYS LIBRARY TRACK ::
  TYPE B B1 HETE ;
assertS FLUX :: 'K-INFINITY' 1 1.112264 ;
EDITION := EDI: EDITION LIBRARY TRACK FLUX ::
  EDIT 3 SAVE COND 4.0 TAKE REGI 1 4 7 10 16 24 ;
FLUX SYS := DELETE: FLUX SYS ;
SYS := ASM: LIBRARY TRACK INTLIN ::
  EDIT 0 PIJ ECCO ;
FLUX := FLU: SYS LIBRARY TRACK ::
  TYPE B B1 ECCO ;
assertS FLUX :: 'K-INFINITY' 1 1.112270 ;
EDITION := EDI: EDITION LIBRARY TRACK FLUX ::
  EDIT 3 SAVE COND 4.0 TAKE REGI 1 4 7 10 16 24 ;
FLUX SYS TRACK INTLIN := DELETE: FLUX SYS TRACK INTLIN ;
*-----
* CASE WITH COOLANT VOIDED
* Self-Shielding calculation EXCEL
* Transport calculation EXCEL
* Flux TYPE K AND B WITH VARIOUS LEAKAGE OPTIONS
*-----
TRACK INTLIN := EXCELT: CANDU6SV ::
  TITLE 'TCWU07: CANDU-6 CARTESIAN FUEL TEMP= 941.29'
  EDIT 0 MAXR 14 TRAK TISO 7 20.0 SYMM 4 ;
LIBRARY := SHI: LIBRARY TRACK INTLIN :: EDIT 0 NOLJ ;
TRACK INTLIN := DELETE: TRACK INTLIN ;
TRACK INTLIN := EXCELT: CANDU6TV ::
  TITLE 'TCWU07: CANDU-6 CARTESIAN FUEL TEMP= 941.29'
  EDIT 0 MAXR 32 ANIS 2 TRAK TISO 7 20.0 SYMM 4 ;
SYS := ASM: LIBRARY TRACK INTLIN ::
  EDIT 0 PIJK ;
FLUX := FLU: SYS LIBRARY TRACK ::
  TYPE K ;
assertS FLUX :: 'K-EFFECTIVE' 1 1.139288 ;
EDITION := EDI: EDITION LIBRARY TRACK FLUX ::
  EDIT 3 SAVE COND 4.0 TAKE REGI 1 4 7 10 16 24 ;
FLUX := FLU: FLUX SYS LIBRARY TRACK ::
  TYPE B B1 PNL ;
assertS FLUX :: 'K-INFINITY' 1 1.131289 ;
EDITION := EDI: EDITION LIBRARY TRACK FLUX ::
  EDIT 3 SAVE COND 4.0 TAKE REGI 1 4 7 10 16 24 ;
FLUX := FLU: FLUX SYS LIBRARY TRACK ::
  TYPE B B1 HETE ;
assertS FLUX :: 'K-INFINITY' 1 1.131540 ;
EDITION := EDI: EDITION LIBRARY TRACK FLUX ::

```

```

EDIT 3 SAVE COND 4.0 TAKE REGI 1 4 7 10 16 24 ;
FLUX SYS := DELETE: FLUX SYS ;
SYS := ASM: LIBRARY TRACK INTLIN ::
  EDIT 0 PIJ ECCO ;
FLUX := FLU: SYS LIBRARY TRACK ::
  TYPE B B1 ECCO ;
assertS FLUX :: 'K-INFINITY' 1 1.131549 ;
EDITION := EDI: EDITION LIBRARY TRACK FLUX ::
  EDIT 3 SAVE COND 4.0 TAKE REGI 1 4 7 10 16 24 ;
FLUX SYS TRACK INTLIN := DELETE: FLUX SYS TRACK INTLIN ;
ECHO "test TCWU07 completed" ;
END: ;
QUIT "LIST" .

```

### 8.5.8 (TCWU08) – Burnup of an homogeneous cell.

This case illustrate the burnup of an homogeneous cell that spends the first 1000 days in a reactor before being removed. The depletion of the isotopes in this cell for an additional 1000 days outside of the core is also investigated.

Input data for test case: **TCWU08.x2m**

```

*-----
* TEST CASE TCWU08
* HOMOGENEOUS DEPLETION CASE
* iaea WLUP Library
*
* REF: None
*
*-----
* Define variables
*   Burnup parameters
*   a) Power
*     = 600.0 kw/kg for 0.0 to 1000.0 days
*     = 0.0 kw/kg for 1000.0 to 2000.0 days
*   b) Burnup time interval Delt
*     = 10 days for 0 to 50 days
*     = 50 days for 50 to 500 days
*     = 100 days for 500 to 1000 days
*     = 1000 days for 1000 to 2000 days
*   c) Editing time Timec
*     = 0.0, 50.0, 500.0, 1000.0 and 2000.0 days
*   d) Burnup control time variables Timei, Timef, TotalTime
*     Timei = initial time
*     Timef = final time
*     TotalTime = Final time reached
*   d) Print variable Iprint
*     = 1 reduced print
*     = 3 full print
*-----
REAL
  Power Delt Timec Timei Timef TotalTime :=
  600.0 10.0 50.0 0.0 0.0 2000.0 ;
INTEGER

```



```

    Iprint := 1 ;
*-----
* Define STRUCTURES and MODULES used
*-----
LINKED_LIST
  LIBRARY HOM TRACK PIJ FLUX BURNUP EDITION ;
MODULE
  GEO: SYBILT: LIB: SHI: ASM: FLU: EVO: EDI: DELETE: END: ;
PROCEDURE assertS ;
*-----
* Depletion data from file iaea format WIMSD4
* Microscopic cross sections from file iaea format WIMSD4
*-----
LIBRARY := LIB: ::
  NMIX 1 CTRA WIMS
  DEPL LIB: WIMSD4 FIL: iaea
  MIXS LIB: WIMSD4 FIL: iaea
  MIX 1 300.0                H1      = '3001'      2.00000E+1
    U235      = '2235'      1.0      1
    U236      = '8238'      0.0      1
  ;
*-----
* Geometry HOM : Homogeneous geometry
*-----
HOM := GEO: :: HOMOGE
  MIX 1 ;
*-----
* Self-Shielding calculation SYBIL
* Transport calculation      SYBIL
* Flux calculation for keff
*-----
TRACK := SYBILT: HOM  ::
  TITLE 'TCWW08: HOMOGENEOUS BENCHMARK WITH BURNUP' ;
LIBRARY := SHI: LIBRARY TRACK :: EDIT 0 NOLJ ;
PIJ := ASM: LIBRARY TRACK ;
FLUX := FLU: PIJ LIBRARY TRACK ::
  TYPE K ;
assertS FLUX :: 'K-EFFECTIVE' 1 1.871363 ;
EDITION := EDI: LIBRARY TRACK FLUX ::
  COND 4.0 MERGE COMP SAVE ;
*-----
* Burnup loop: for first step BURNUP is created
* while for other steps it is modified
*-----
WHILE Timei TotalTime < DO
  EVALUATE Timef := Timei Delt + ;
  IF Timef Timec = THEN
    EVALUATE Iprint := 3 ;
  ELSE
    EVALUATE Iprint := 1 ;
  ENDIF ;
  IF Timei 0.0 = THEN
    BURNUP LIBRARY := EVO: LIBRARY FLUX TRACK ::
      EDIT <<Iprint>> DEPL <<Timei>> <<Timef>> DAY
      POWR <<Power>> ;

```

```

ELSE
  BURNUP LIBRARY := EVO: BURNUP LIBRARY FLUX TRACK ::
    EDIT <<Iprint>> NOEX DEPL <<Timei>> <<Timef>> DAY
    POWR <<Power>> ;
ENDIF ;
LIBRARY := SHI: LIBRARY TRACK :: EDIT 0 NOLJ ;
PIJ := DELETE: PIJ ;
PIJ := ASM: LIBRARY TRACK ;
FLUX := FLU: FLUX PIJ LIBRARY TRACK ::
  TYPE K ;
IF Iprint 3 = THEN
  EDITION := EDI: EDITION LIBRARY TRACK FLUX ::
    SAVE ;
ENDIF ;
*-----
* change delta t for burnup, final time and power if required
*-----
IF Timef Timec = THEN
  IF Timec 1000.0 = THEN
    EVALUATE Power Delt Timec := 0.0 1000.0 2000.0 ;
  ENDIF ;
  IF Timec 500.0 = THEN
    EVALUATE Delt Timec := 100.0 1000.0 ;
  ENDIF ;
  IF Timec 50.0 = THEN
    EVALUATE Delt Timec := 50.0 500.0 ;
  ENDIF ;
ENDIF ;
EVALUATE Timei := Timef ;
ENDWHILE ;
assertS FLUX :: 'K-EFFECTIVE' 1 1.184694 ;
ECHO "test TCWU08 completed" ;
END: ;
QUIT "LIST" .

```

### 8.5.9 (TCWU09) – Testing boundary conditions.

This case test different boundary conditions for the Mosteller cell.

Input data for test case: **TCWU09.x2m**

```

*-----
* TEST CASE TCWU09
* MOSTELLER BENCHMARK FOR 1-D ANNULAR CELL
* iaea WLUP Library
* REFLECTIVE AND VOID BC
*
* REF: None
*
*-----
* Define STRUCTURES and MODULES used
*-----
LINKED_LIST
  MOSTELA MOSTELV VOLMAT LIBRARY PIJ FLUX OUT ;

```

```

MODULE
  LIB: GEO: SYBILT: SHI: ASM: FLU: EDI: DELETE: END: ;
PROCEDURE assertS ;
*-----
* Microscopic cross section from file iaea format WIMSD4
*-----
LIBRARY := LIB: ::
  NMIX 3 CTRA WIMS
  MIXS LIB: WIMSD4 FIL: iaea
  MIX 1 600.0                016      = '6016'    4.61309E-2
    U235      = '2235'    1.66078E-4 1
    U238      = '8238'    2.28994E-2 1
  MIX 2 600.0
    Zr91      = '91'      3.83243E-2
  MIX 3 600.0
    H1H20     = '3001'    4.42326E-2  016H20   = '6016'    2.21163E-2
    BNat      = '1011'    1.02133E-5
  ;
*-----
* Geometry MOSTELA : Annular cell with reflective BC
*           MOSTELV : Annular cell with void BC
*-----
MOSTELA := GEO: :: TUBE 3
  RADIUS 0.0 0.39306 0.45802 0.71206
  SPLITR  2      1      1
  MIX      1      2      3
  R+ REFL ;
MOSTELV := GEO: MOSTELA ::
  R+ VOID ;
*-----
* Self-Shielding calculation SYBIL
* Transport calculation      SYBIL
* Flux calculation for keff
*-----
VOLMAT := SYBILT: MOSTELA ::
  TITLE 'TCWU09: SYBIL TRACK MOSTELLER BENCHMARK REFLECTIVE BC '
  MAXR 4 QUA1 5 ;
LIBRARY := SHI: LIBRARY VOLMAT :: EDIT 0 NOLJ ;
PIJ := ASM: LIBRARY VOLMAT ;
FLUX := FLU: PIJ LIBRARY VOLMAT ::
  TYPE K ;
assertS FLUX :: 'K-EFFECTIVE' 1 0.8276187 ;
OUT := EDI: LIBRARY VOLMAT FLUX ::
  EDIT 4 MERG MIX 1 2 3 COND 4.0 SAVE ;
PIJ VOLMAT := DELETE: PIJ VOLMAT ;
VOLMAT := SYBILT: MOSTELV ::
  TITLE 'TCWU09: SYBIL TRACK MOSTELLER BENCHMARK VOID BC '
  MAXR 4 QUA1 5 ;
PIJ := ASM: LIBRARY VOLMAT ;
FLUX := FLU: FLUX PIJ LIBRARY VOLMAT ::
  TYPE K ;
assertS FLUX :: 'K-EFFECTIVE' 1 1.023486E-02 ;
OUT := EDI: OUT LIBRARY VOLMAT FLUX ::
  EDIT 4 MERG MIX 1 2 3 COND 4.0 SAVE ;
OUT FLUX PIJ LIBRARY VOLMAT := DELETE:

```



```

;
*-----
* Geometry MOSTELA : Annular cell with reflective BC
*-----
MOSTELA := GEO: :: TUBE 3
  RADIUS 0.0 0.39306 0.45802 0.71206
  SPLITR   2       1       1
  MIX      1       2       3
  R+ REFL ;
*-----
* Self-Shielding calculation SYBIL
* Transport calculation      SYBIL
* Flux calculation for keff
*-----
VOLMAT := SYBILT: MOSTELA ::
  TITLE 'TCWU10: SYBIL TRACK MOSTELLER BENCHMARK'
  MAXR 4 QUA1 5 ;
LIBRARY := SHI: LIBRARY VOLMAT :: EDIT 0 NOLJ ;
PIJ := ASM: LIBRARY VOLMAT ;
FLUX := FLU: PIJ LIBRARY VOLMAT ::
  TYPE K ;
assertS FLUX :: 'K-EFFECTIVE' 1 0.8276187 ;
OUT := EDI: LIBRARY VOLMAT FLUX ::
  EDIT 4 MERG MIX 1 2 3 COND 4.0 ;
FLUX := DELETE: FLUX ;
FLUX := FLU: PIJ LIBRARY VOLMAT :: EDIT 99
  TYPE S EXTE 30 UNKT 1.0E-3 ;
assertV FLUX :: 'FLUX' (*GROUP*) 10 (*REGION*) 4 4.291752E+05 ;
OUT := EDI: OUT LIBRARY VOLMAT FLUX ::
  EDIT 4 MERG MIX 1 2 3 COND 4.0 ;
OUT FLUX PIJ LIBRARY VOLMAT := DELETE:
  OUT FLUX PIJ LIBRARY VOLMAT ;
ECHO "test TCWU10 completed" ;
END: ;
QUIT "LIST" .

```

### 8.5.11 (TCWU11) – Two group burnup of a CANDU-6 type cell.

This case is similar to (TCWU05) except that the burnup module uses DRAGON generated two groups time dependent microscopic cross sections. The MICROLIB is defined by the procedure TCWU05Lib.c2m presented in Section 8.5.19.

Input data for test case: **TCWU11.x2m**

```

*-----
* TEST CASE TCWU11
* CANDU-6 ANNULAR CELL
* iaea WLUP Library
* TWO GROUP BURNUP
* POWER (KW)           = 615.00000
* BURN POWER (KW/KG)  = 31.97130
* URANIUM MASS         = 19.23600
* UO2 REAL DENSITY    = 10.59300
* UO2 EFF DENSITY     = 10.43750

```

```

* UO2 TEMPERATURE      = 941.28998
* ENRICHMENT            = 0.71140
* COOLANT D2 AT %      = 99.222
* MODERATOR D2 AT %    = 99.911
* NUMBER OF DAYS       = 50
*
*-----
* Define variables
*   Burnup paremeters
*   a) Power
*     = 31.9713 kw/kg for 0.0 to 300.0 days
*   b) 69 Groups Burnup time interval Delt
*     = 300 day for 0 to 300 day
*   c) 2 Groups Burnup time interval Delt
*     = 1 day for 0 to 1 day
*     = 4 days for 1 to 5 days
*     = 5 days for 5 to 10 days
*     = 10 days for 10 to 50 days
*     = 20 days for 50 to 150 days
*     = 50 days for 150 to 300 days
*   c) Days with burnup interval changes
*     = 1.0, 5.0, 10.0, 50.0, 150.0 and 300.0 days
*   d) Burnup control time variables Timei, Timef
*     Timei = initial time
*     Timef = final time
*-----
REAL
  Power    Delt    Timec    Timei Timef :=
  31.9713  1.0     300.0    0.0   0.0 ;
*-----
* Define STRUCTURES and MODULES used
*-----
LINKED_LIST LIBRARY ;
LINKED_LIST
  CANDU6S CANDU6F VOLMATS VOLMATF PIJ FLUX BURNUP EDITION ;
SEQ_BINARY
  INTLINS INTLINF ;
SEQ_ASCII
  res ;
MODULE
  GEO: EXCELT: LIB: SHI: ASM: FLU: EVO: EDI: SPH: DELETE: END: ;
PROCEDURE assertS ;
*-----
* Depletion data from file iaea format WIMSD4
* Microscopic cross sections from file iaea format WIMSD4
*-----
PROCEDURE TCWU05Lib ;
INTEGER  iedit := 1 ;
LIBRARY := TCWU05Lib :: <<iedit>> ;
*-----
* Geometry CANDU6S : 13 regions annular cluster for self-shielding
*                   CANDU6F : 31 regions annular cluster for transport
*-----
CANDU6S := GEO: :: TUBE 5
  R+ REFL RADIUS 0.00000 5.16890 5.60320 6.44780 6.58750 16.12171

```

```

MIX  1 2 3 4 5
CLUSTER ROD1 ROD2 ROD3 ROD4
::: ROD1 := GEO: TUBE 2 MIX 6 10 NPIN  1 RPIN 0.0000 APIN 0.0000
      RADIUS 0.00000 0.6122 0.6540 ;
::: ROD2 := GEO: ROD1  MIX 7 10 NPIN  6 RPIN 1.4885 APIN 0.0000 ;
::: ROD3 := GEO: ROD1  MIX 8 10 NPIN 12 RPIN 2.8755 APIN 0.261799 ;
::: ROD4 := GEO: ROD1  MIX 9 10 NPIN 18 RPIN 4.3305 APIN 0.0 ;
;
CANDU6F := GEO: CANDU6S :: SPLITR  6 1 1 1 10
::: ROD1 := GEO: ROD1 SPLITR 2 1 ;
::: ROD2 := GEO: ROD2 SPLITR 2 1 ;
::: ROD3 := GEO: ROD3 SPLITR 2 1 ;
::: ROD4 := GEO: ROD4 SPLITR 2 1 ;
;
*-----
* Self-Shielding calculation EXCEL
* Transport calculation      EXCEL
* Flux calculation for keff
*-----
VOLMATS INTLINS := EXCELT: CANDU6S ::
  TITLE 'TCWU11: FEW GROUP BURNUP / SELF-SHIELDING TRACKING'
  EDIT 0 MAXR 13 TRAK TISO 5 10.0 SYMM 12 ;
LIBRARY := SHI: LIBRARY VOLMATS INTLINS :: EDIT 0 NOLJ ;
VOLMATF INTLINF := EXCELT: CANDU6F ::
  TITLE 'TCWU11: FEW GROUP BURNUP / TRANSPORT TRACKING'
  EDIT 0 MAXR 31 TRAK TISO 5 10.0 SYMM 12 ;
PIJ := ASM: LIBRARY VOLMATF INTLINF ;
FLUX := FLU: PIJ LIBRARY VOLMATF ::
  TYPE K ;
assertS FLUX :: 'K-EFFECTIVE' 1 1.121035 ;
EDITION := EDI: LIBRARY VOLMATF FLUX CANDU6F ::
  MERG REGI  6  6 10  7  7 10  1  1  8  8 10  1
             1  9  9 10  1  1  2  3  4  5  5  5
             5  5  5  5  5  5  5
  COND 4.0 MICR ALL SAVE
  MGEO CANDU6F
;
EDITION := SPH: EDITION VOLMATF INTLINF ;
*-----
* 69 group Burnup
*-----
BURNUP LIBRARY := EVO: LIBRARY FLUX VOLMATF ::
  EDIT 3 EXPM 200.0 DEPL <<Timei>> <<Timec>> DAY POWR <<Power>> ;
LIBRARY := SHI: LIBRARY VOLMATS INTLINS :: EDIT 0 NOLJ ;
PIJ := DELETE: PIJ ;
PIJ := ASM: LIBRARY VOLMATF INTLINF ;
FLUX := FLU: FLUX PIJ LIBRARY VOLMATF ::
  TYPE K ;
assertS FLUX :: 'K-EFFECTIVE' 1 0.9414081 ;
EDITION := EDI: EDITION LIBRARY VOLMATF FLUX CANDU6F ::
  MGEO CANDU6F
;
EDITION := SPH: EDITION VOLMATF INTLINF ;
BURNUP FLUX PIJ LIBRARY INTLINS VOLMATS CANDU6S := DELETE:
  BURNUP FLUX PIJ LIBRARY INTLINS VOLMATS CANDU6S ;

```

```

*-----
* 2 group Burnup
*-----
LIBRARY := EDITION :: STEP UP 'REF-CASE0001' ;
EDITION := DELETE: EDITION ;
PIJ := ASM: LIBRARY VOLMATF INTLINF ;
FLUX := FLU: PIJ LIBRARY VOLMATF ::
    TYPE K ;
assertS FLUX :: 'K-EFFECTIVE' 1 1.121052 ;
EDITION := EDI: LIBRARY VOLMATF FLUX ::
    EDIT 1 MERGE COMP MICR ALL SAVE ;
EVALUATE Timec := 1.0 ;
WHILE Timei Timec < DO
    EVALUATE Timef := Timei Delt + ;
    IF Timei 0.0 = THEN
        BURNUP LIBRARY := EVO: LIBRARY FLUX VOLMATF ::
            EDIT 3 DEPL <<Timei>> <<Timef>> DAY POWR <<Power>> ;
    ELSE
        BURNUP LIBRARY := EVO: BURNUP LIBRARY FLUX VOLMATF ::
            EDIT 3 NOEX DEPL <<Timei>> <<Timef>> DAY POWR <<Power>> ;
    ENDIF ;
    PIJ := DELETE: PIJ ;
    PIJ := ASM: LIBRARY VOLMATF INTLINF ;
    FLUX := FLU: FLUX PIJ LIBRARY VOLMATF ::
        TYPE K ;
    EDITION := EDI: EDITION LIBRARY VOLMATF FLUX ::
        SAVE ;
*-----
* change delta t for burnup and final time if required
*-----
    IF Timef Timec = THEN
        IF Timec 5.0 = THEN
            EVALUATE Delt Timec := 5.0 10.0 ;
        ENDIF ;
        IF Timec 1.0 = THEN
            EVALUATE Delt Timec := 4.0 5.0 ;
        ENDIF ;
    ENDIF ;
    EVALUATE Timei := Timef ;
ENDWHILE ;
assertS FLUX :: 'K-EFFECTIVE' 1 1.075327 ;
res := EDITION ;
EDITION BURNUP FLUX PIJ LIBRARY INTLINF VOLMATF CANDU6F := DELETE:
    EDITION BURNUP FLUX PIJ LIBRARY INTLINF VOLMATF CANDU6F ;
ECHO "test TCWU11 completed" ;
END: ;
QUIT "LIST" .

```

### 8.5.12 (TCWU12) – Mixture composition.

This case illustrates the use of the INFO: module of DRAGON (see Section 3.11) as well as the new COMB option in the module LIB: (see Section 3.2).



Input data for test case: **TCWU12.x2m**

```

*-----
* TEST CASE TCWU12
* iaea WLUP Library
* GENERATE A LIBRARY USING INFO AND OTHER OPTIONS
*
* REF: None
*
*-----
* Define variables and initialize
* Coolant properties
* a) Input
* TempCool = Coolant temperature (K)
* Purity = D2/(D2+H1) Weight % ratio in Coolant
* b) Output
* DensCool = Coolant Density (g/cm**3)
* WH1C = H1 Weight % in Coolant
* WD2C = D2 Weight % in Coolant
* W016C = O16 Weight % in Coolant
* Fuel properties
* a) Input
* TempFuel = Fuel temperature (K)
* Enrichment = U235/(U235+U238) Weight % ratio in Fuel
* DensFuel = Fuel Density (g/cm**3)
* b) Output
* WU235F = U235 Weight % in Fuel
* WU238F = U238 Weight % in Fuel
* W016F = O16 Weight % in Fuel
*-----
REAL
TempCool Purity TempFuel Enrichment DensFuel :=
560.66 99.95 941.29 0.72 10.437501 ;
REAL
WH1C WD2C W016C DensCool Pres
WU235F WU238F W016F ;
*-----
* Define STRUCTURES and MODULES used
*-----
LINKED_LIST
LIBRARY ISOT ;
MODULE
LIB: INFO: END: ;
PROCEDURE asserts ;
*-----
* Get Coolant properties
*-----
ECHO
"Case 1. Coolant density vs temperature " ;
ECHO
"Input - Coolant temperature (K) " TempCool ;
ECHO
"Input - D2/(D2+H1) Weight % ratio in Coolant" Purity ;
INFO: ::
TMP: <<TempCool>> K
PUR: <<Purity>> WGT%

```

```

    CALC DENS WATER >>DensCool<<
    LIB: WIMSD4 FIL: iaea
    ISO: 3 '3001' '3002' '6016'
    CALC WGT% D20 >>WH1C<< >>WD2C<< >>W016C<<
;
ECHO
    "Output - Coolant Density (g/cm**3)" DensCool ;
ECHO
    "Output - H1 Weight % in Coolant " WH1C ;
ECHO
    "Output - D2 Weight % in Coolant " WD2C ;
ECHO
    "Output - 016 Weight % in Coolant " W016C ;
ECHO
    "Case 2. Coolant density vs temperature and pressure " ;
EVALUATE
    TempCool Purity Pres :=
    366.72 100.0 20.8 ;
ECHO
    "Input - Coolant temperature (K) " TempCool ;
ECHO
    "Input - Coolant pressure (MPa) " Pres ;
ECHO
    "Input - D2/(D2+H1) Weight % ratio in Coolant" Purity ;
INFO: ::
    TMP: <<TempCool>> C
    PRES: <<Pres>> MPa
    PUR: <<Purity>> WGT%
    CALC DENS PWATER >>DensCool<<
    LIB: WIMSD4 FIL: iaea
    ISO: 3 '3001' '3002' '6016'
    CALC WGT% D20 >>WH1C<< >>WD2C<< >>W016C<<
;
ECHO
    "Output - Coolant Density (g/cm**3)" DensCool ;
ECHO
    "Output - H1 Weight % in Coolant " WH1C ;
ECHO
    "Output - D2 Weight % in Coolant " WD2C ;
ECHO
    "Output - 016 Weight % in Coolant " W016C ;
ECHO
    "Case 3. Fuel enrichment " ;
*-----
* Get Fuel properties
*-----
ECHO
    "Input - Fuel temperature (K) " TempFuel ;
ECHO
    "Input - U235/(U235+U238) Weight % ratio in Fuel" Enrichment ;
ECHO
    "Input - Fuel Density (g/cm**3) " DensFuel ;
INFO: ::
    ENR: <<Enrichment>> WGT%
    LIB: WIMSD4 FIL: iaea

```

```

      ISO: 3 '2235'      '8238'      '6016'
      CALC WGT% U02 >>WU235F<< >>WU238F<< >>W016F<<
;
ECHO
  "Output - U235 Weight % in Fuel" WU235F ;
ECHO
  "Output - U238 Weight % in Fuel" WU238F ;
ECHO
  "Output - 016 Weight % in Fuel " W016F ;
*-----
* Microscopic cross sections from file iaea format WIMSD4
*-----
LIBRARY := LIB: ::
  NMIX 5 CTRA WIMS
  MIXS LIB: WIMSD4 FIL: iaea
  MIX 1 <<TempCool>> <<DensCool>> 016      = '6016' <<W016C>>
      D2D20      = '3002' <<WD2C>> H1H20      = '3001' <<WH1C>>
  MIX 2 <<TempFuel>> <<DensCool>> 016      = '6016' <<W016C>>
      D2D20      = '3002' <<WD2C>> H1H20      = '3001' <<WH1C>>
  MIX 3 <<TempFuel>> <<DensFuel>> 016      = '6016' <<W016F>>
      U235      = '2235' <<WU235F>> 1
      U238      = '8238' <<WU238F>> 1
  MIX 4 COMB 2 0.5 0 0.5
  MIX 5 COMB 3 0.1 3 0.9
;
ISOT := LIBRARY :: STEP UP ISOTOPESLIST STEP AT 15 ; (*U238 0005*)
assertS ISOT :: NG 35 5.000504E-01 ;
ECHO "test TCWU12 completed" ;
END: ;
QUIT "LIST" .

```

### 8.5.13 (TCWU13) – Solution by the method of cyclic characteristics

This case illustrates the use of the MOCC: module of DRAGON for a solution by the transport equation by the method of cyclic characteristics. This test case also uses the embedded DRAGON procedure stored in the TCWU05Lib.c2m file.

Input data for test case: **TCWU13.x2m**

```

*-----
* TEST CASE TCWU13
* 17 X 17 PWR ASSEMBLY WITHOUT POISON
* WIMSD4 69 GROUPS LIBRARY FILE iaea FROM WLUP
*
* REF: none
*
*-----
* Define STRUCTURES and MODULES used
*-----
LINKED_LIST
  ASSMB DISCR1 DISCR2 LIBRARY CP CALC OUT DATABASE ISOT SPHGEOM
  MTRACK ;
SEQ_BINARY FILTRK ;
SEQ_ASCII

```

```

res ;
MODULE
LIB: GEO: SYBILT: NXT: BIVACT: SHI: ASM: FLU: EDI: COMPO: SPH:
DELETE: END: ;
PROCEDURE assertS ;
*-----
* Microscopic cross sections from file iaea format WIMSD4
*-----
LIBRARY := LIB: ::
NMIX 8 CTRA WIMS
MIXS LIB: WIMSD4 FIL: iaea
MIX 1 579.9
  H1H20 = '3001' 4.76690E-2 016H20 = '6016' 2.38345E-2
  BNat = '1011' 2.38103E-5
MIX 2 579.9
  Cr52 = '52' 7.54987E-5 Fe56 = '2056' 1.47624E-4
  Zr91 = '91' 4.18621E-2
MIX 3 579.9
  H1H20 = '3001' 4.65292E-2 016H20 = '6016' 2.32646E-2
  Cr52 = '52' 4.79927E-5
  Fe56 = '2056' 4.45845E-5 Ni58 = '58' 1.13521E-4
  MoNat = '96' 4.03755E-6
  Al27 = '27' 2.35231E-6
  Mn55 = '55' 4.15901E-7
  BNat = '1011' 2.32761E-5
  Zr91 = '91' 8.92427E-4
MIX 4 579.9
  Cr52 = '52' 7.07291E-5 Fe56 = '2056' 1.38298E-4
  Zr91 = '91' 3.92175E-2
MIX 5 579.9
  H1H20 = '3001' 4.71346E-2 016H20 = '6016' 2.35673E-2
  Cr52 = '52' 2.24991E-5
  Fe56 = '2056' 2.09013E-5 Ni58 = '58' 5.32188E-5
  MoNat = '96' 1.89281E-6
  Al27 = '27' 1.10277E-6
  Mn55 = '55' 1.94976E-7
  BNat = '1011' 2.35598E-5
  Zr91 = '91' 4.18372E-4
MIX 6 579.9
  H1H20 = '3001' 4.71676E-2 016H20 = '6016' 2.35838E-2
  Cr52 = '52' 2.11122E-5
  Fe56 = '2056' 1.96130E-5 Ni58 = '58' 4.99383E-5
  MoNat = '96' 1.77614E-6
  Al27 = '27' 1.03479E-6
  Mn55 = '55' 1.82957E-7
  BNat = '1011' 2.35753E-5
  Zr91 = '91' 3.92583E-4
MIX 7 579.9
  H1H20 = '3001' 4.72020E-2 016H20 = '6016' 2.36010E-2
  Cr52 = '52' 1.96591E-5
  Fe56 = '2056' 1.82630E-5 Ni58 = '58' 4.65011E-5
  MoNat = '96' 1.65389E-6
  Al27 = '27' 9.63569E-7
  Mn55 = '55' 1.70365E-7
  BNat = '1011' 2.35914E-5

```

```

      Zr91      = '91'      3.65562E-4
MIX 8 933.6      016      = '6016'      4.49355E-2
      U235      = '2235'    7.39237E-4 1
      U238      = '8238'    2.17285E-2 1
;
*-----
* Geometry ASSMB : a 17 X 17 normal PWR assembly
* contains C1 : cell without fuel
*           C2 : normal fuel cell
*           C3 : peripheral cell
*           C4 : corner cell
*-----
ASSMB := GEO: :: CAR2D 9 9
      X- DIAG X+ REFL Y- SYME Y+ DIAG
      CELL C1 C2 C2 C1 C2 C2 C1 C2 C3
            C2 C2 C2 C2 C2 C2 C2 C3
            C2 C2 C2 C2 C2 C2 C3
            C1 C2 C2 C1 C2 C3
            C2 C2 C2 C2 C3
            C1 C2 C2 C3
            C2 C2 C3
            C2 C3
            C4

      ::: C1 := GEO: CARCEL 2
      MESHX 0.0 1.26472 MESHY 0.0 1.26472
      RADIUS 0.0 0.572435 0.613142 MIX 1 2 3 ;
      ::: C2 := GEO: C1 RADIUS 0.0 0.412660 0.474364 MIX 8 4 5 ;
      ::: C3 := GEO: C2 MESHX 0.0 1.31472 MIX 8 4 6 ;
      ::: C4 := GEO: C3 MESHY 0.0 1.31472 MIX 8 4 7 ;
;
*-----
* Self-Shielding calculation SYBIL
* Transport calculation SYBIL
* Flux calculation for B1 homogeneous leakage
* Editing using SPH model for transport-diffusion
*-----
DISCR1 := SYBILT: ASSMB ::
      TITLE 'TCWU13: 17 X 17 MULTICELL PWR BENCHMARK WITHOUT POISON'
      MAXR 400 QUA2 6 3 ;
DISCR2 FILTRK := NXT: ASSMB ::
      TITLE 'TCWU13: 17 X 17 MULTICELL PWR BENCHMARK WITHOUT POISON'
      TISO 10 20.0 ;
LIBRARY := SHI: LIBRARY DISCR1 :: EDIT 0 NOLJ ;

CP := ASM: LIBRARY DISCR2 FILTRK ;
CALC := FLU: CP LIBRARY DISCR2 ::
      TYPE B B1 PNL ;
assertS CALC :: 'K-INFINITY' 1 1.256567 ;

OUT := EDI: LIBRARY DISCR1 CALC ASSMB ::
      EDIT 3 UPS SAVE MICR RES MERGE CELL COND 4.0
;
ECHO "test TCWU13 completed" ;
END: ;
QUIT "LIST" .

```

## 8.5.14 (TCWU14) – SPH Homogenisation without tracking

This case illustrates the use of the SPH homogenisation procedure in the EDI: module of DRAGON when a tracking data structure is provided as input. This test case also uses the embedded DRAGON procedure stored in the TCWU05Lib.c2m file.

Input data for test case: **TCWU14.x2m**

```

*-----
* TEST CASE TCWU14
* CANDU-6 ANNULAR CELL
* iaea WLUP Library
*-----
*-----
* Define STRUCTURES and MODULES used
*-----
LINKED_LIST
  LIBRARY CANDU6S CANDU6F VOLMATS VOLMATF PIJ FLUX EDITION
  DATABASE ISOT ;
SEQ_BINARY
  INTLINS INTLINF ;
SEQ_ASCII
  database ;
MODULE
  GEO: NXT: SHI: ASM: FLU: EDI: DELETE: END: ;
PROCEDURE assertS ;
*-----
* Depletion data from file iaea format WIMSD4
* Microscopic cross sections from file iaea format WIMSD4
*-----
PROCEDURE TCWU05Lib ;
INTEGER  iedit := 1 ;
LIBRARY := TCWU05Lib :: <<iedit>> ;
*-----
* Geometry CANDU6S : 13 regions annular cluster for self-shielding
* CANDU6F : 31 regions annular cluster for transport
*-----
CANDU6S := GEO: :: CARCEL 5
  X+ REFL X- REFL
  Y+ REFL Y- REFL
  MESHX -14.2875 14.2875
  MESHY -14.2875 14.2875
  RADIUS 0.00000 5.16890 5.60320 6.44780 6.58750 14.00
  MIX 1 2 3 4 5 5
  CLUSTER ROD1 ROD2 ROD3 ROD4
  :: ROD1 := GEO: TUBE 2 MIX 6 10 NPIN 1 RPIN 0.0000 APIN 0.0000
  RADIUS 0.00000 0.6122 0.6540 ;
  :: ROD2 := GEO: ROD1 MIX 7 10 NPIN 6 RPIN 1.4885 APIN 0.0000 ;
  :: ROD3 := GEO: ROD1 MIX 8 10 NPIN 12 RPIN 2.8755 APIN 0.261799 ;
  :: ROD4 := GEO: ROD1 MIX 9 10 NPIN 18 RPIN 4.3305 APIN 0.0 ;
;
CANDU6F := GEO: :: CAR2D 2 2
  X+ REFL X- REFL
  Y+ REFL Y- REFL
  CELL F1 F2 F3 F4

```

```

::: F1 := GEO: CARCEL 5
MESHX -14.2875 14.2875
MESHY -14.2875 14.2875
RADIUS 0.00000 5.16890 5.60320 6.44780 6.58750 14.00
MIX 1 2 3 4 5 5
CLUSTER ROD1 ROD2 ROD3 ROD4
::: ROD1 := GEO: TUBE 2 MIX 6 10 NPIN 1 RPIN 0.0000 APIN 0.0000
RADIUS 0.00000 0.6122 0.6540 ;
::: ROD2 := GEO: ROD1 MIX 7 10 NPIN 6 RPIN 1.4885 APIN 0.0000 ;
::: ROD3 := GEO: ROD1 MIX 8 10 NPIN 12 RPIN 2.8755 APIN 0.261799 ;
::: ROD4 := GEO: ROD1 MIX 9 10 NPIN 18 RPIN 4.3305 APIN 0.0 ;
;
::: F2 := GEO: CARCEL 5
MESHX -14.2875 14.2875
MESHY -14.2875 14.2875
RADIUS 0.00000 5.16890 5.60320 6.44780 6.58750 14.00
MIX 1 2 3 4 5 5
CLUSTER ROD1 ROD2 ROD3 ROD4
::: ROD1 := GEO: TUBE 2 MIX 6 10 NPIN 1 RPIN 0.0000 APIN 0.0000
RADIUS 0.00000 0.6122 0.6540 ;
::: ROD2 := GEO: ROD1 MIX 7 10 NPIN 6 RPIN 1.4885 APIN 0.0000 ;
::: ROD3 := GEO: ROD1 MIX 8 10 NPIN 12 RPIN 2.8755 APIN 0.261799 ;
::: ROD4 := GEO: ROD1 MIX 9 10 NPIN 18 RPIN 4.3305 APIN 0.0 ;
;
::: F3 := GEO: CARCEL 5
MESHX -14.2875 14.2875
MESHY -14.2875 14.2875
RADIUS 0.00000 5.16890 5.60320 6.44780 6.58750 14.00
MIX 1 2 3 4 5 5
CLUSTER ROD1 ROD2 ROD3 ROD4
::: ROD1 := GEO: TUBE 2 MIX 6 10 NPIN 1 RPIN 0.0000 APIN 0.0000
RADIUS 0.00000 0.6122 0.6540 ;
::: ROD2 := GEO: ROD1 MIX 7 10 NPIN 6 RPIN 1.4885 APIN 0.0000 ;
::: ROD3 := GEO: ROD1 MIX 8 10 NPIN 12 RPIN 2.8755 APIN 0.261799 ;
::: ROD4 := GEO: ROD1 MIX 9 10 NPIN 18 RPIN 4.3305 APIN 0.0 ;
;
::: F4 := GEO: CARCEL 5
MESHX -14.2875 14.2875
MESHY -14.2875 14.2875
RADIUS 0.00000 5.16890 5.60320 6.44780 6.58750 14.00
MIX 1 2 3 4 5 5
CLUSTER ROD1 ROD2 ROD3 ROD4
::: ROD1 := GEO: TUBE 2 MIX 6 10 NPIN 1 RPIN 0.0000 APIN 0.0000
RADIUS 0.00000 0.6122 0.6540 ;
::: ROD2 := GEO: ROD1 MIX 7 10 NPIN 6 RPIN 1.4885 APIN 0.0000 ;
::: ROD3 := GEO: ROD1 MIX 8 10 NPIN 12 RPIN 2.8755 APIN 0.261799 ;
::: ROD4 := GEO: ROD1 MIX 9 10 NPIN 18 RPIN 4.3305 APIN 0.0 ;
;
;
*-----
* Self-Shielding calculation NXT
* Transport calculation NXT
* Flux calculation for keff
*-----
VOLMATS INTLINS := NXT: CANDU6S ::

```

```

TITLE 'TCWU14: CANDU-6 ANNULAR POWER= 31.971 FUEL TEMP= 941.29'
EDIT 0 TISO 50 10.0 ;
LIBRARY := SHI: LIBRARY VOLMATS INTLINS ::
EDIT 0 ;
VOLMATF INTLINF := NXT: CANDU6F ::
TITLE 'TCWU14: CANDU-6 ANNULAR POWER= 31.971 FUEL TEMP= 941.29'
EDIT 0 TISO 50 10.0 ;
PIJ := ASM: LIBRARY VOLMATF INTLINF ;
FLUX := FLU: PIJ LIBRARY VOLMATF ::
TYPE K ;
assertS FLUX :: 'K-INFINITY' 1 1.129156 ;
EDITION := EDI: LIBRARY VOLMATF FLUX ::
COND 4.0 MERGE CELL MICR 1 Xe135 SAVE ON 'fuel' ;
INTLINF INTLINS := DELETE: INTLINF INTLINS ;
ECHO "test TCWU14 completed" ;
END: ;
QUIT "LIST" .

```

#### 8.5.15 (TCWU15) – A CANDU-6 type Cartesian cell with burnup

This test case is similar to **TCWU05** except that the cell boundary are Cartesian and the **NXT:** tracking module is used. It uses the embedded **DRAGON** procedure stored in the **TCWU05Lib.c2m** file.

Input data for test case: **TCWU15.x2m**

```

*-----
* TEST CASE TCWU05
* CANDU-6 ANNULAR CELL
* iaea WLUP Library
* POWER (KW) = 615.00000
* BURN POWER (KW/KG) = 31.97130
* URANIUM MASS = 19.23600
* UO2 REAL DENSITY = 10.59300
* UO2 EFF DENSITY = 10.43750
* UO2 TEMPERATURE = 941.28998
* ENRICHMENT = 0.71140
* COOLANT D2 AT % = 99.222
* MODERATOR D2 AT % = 99.911
* NUMBER OF DAYS = 50
*
*-----
* Define variables and initialize
* Burnup paremeters
* a) Power
* = 31.9713 kw/kg for 0.0 to 300.0 days
* b) Burnup time interval Delt
* = 1 day for 0 to 1 day
* = 4 days for 1 to 5 days
* = 5 days for 5 to 10 days
* = 10 days for 10 to 50 days
* = 20 days for 50 to 150 days
* = 50 days for 150 to 300 days
* c) Days with burnup interval changes
* = 1.0, 5.0, 10.0, 50.0, 150.0 and 300.0 days

```



```

*      d) Burnup control time variables Timei, Timef
*      Timei = initial time
*      Timef = final time
*-----
REAL
  Power      Delt Timec Timei Timef :=
  31.9713   1.0  1.0  0.0  0.0 ;
*-----
* Define STRUCTURES and MODULES used
*-----
LINKED_LIST
  LIBRARY CANDU6S CANDU6F VOLMATS VOLMATF PIJ FLUX BURNUP EDITION
  COMPO1 COMPO2 ;
SEQ_BINARY
  INTLINS INTLINF ;
SEQ_ASCII
  fuel mode ;
MODULE
  GEO: NXT: SHI: ASM: FLU: EVO: EDI: CPO: DELETE: END: ;
*-----
* Depletion data from file iaea format WIMSD4
* Microscopic cross sections from file iaea format WIMSD4
*-----
PROCEDURE TCWU05Lib ;
PROCEDURE assertS ;
INTEGER   iedit := 1 ;
LIBRARY := TCWU05Lib :: <<iedit>> ;
*-----
* Geometry CANDU6S : 13 regions annular cluster for self-shielding
*           CANDU6F : 31 regions annular cluster for transport
*-----
CANDU6S := GEO: :: CARCEL  5
  X+ REFL X- REFL MESHX -14.2875 14.2875
  Y+ REFL Y- REFL MESHY -14.2875 14.2875
  RADIUS  0.00000 5.16890 5.60320  6.44780 6.58750 14.00
  MIX  1 2 3 4 5 5
  CLUSTER ROD1 ROD2 ROD3 ROD4
  ::: ROD1 := GEO: TUBE 2 MIX 6 10 NPIN  1 RPIN 0.0000 APIN 0.0000
  RADIUS 0.00000 0.6122 0.6540 ;
  ::: ROD2 := GEO: ROD1  MIX 7 10 NPIN  6 RPIN 1.4885 APIN 0.0000 ;
  ::: ROD3 := GEO: ROD1  MIX 8 10 NPIN 12 RPIN 2.8755 APIN 0.261799 ;
  ::: ROD4 := GEO: ROD1  MIX 9 10 NPIN 18 RPIN 4.3305 APIN 0.0 ;
  ;
CANDU6F := GEO: CANDU6S :: SPLITR  6 1 1 1 10
  ::: ROD1 := GEO: ROD1 SPLITR 2 1 ;
  ::: ROD2 := GEO: ROD2 SPLITR 2 1 ;
  ::: ROD3 := GEO: ROD3 SPLITR 2 1 ;
  ::: ROD4 := GEO: ROD4 SPLITR 2 1 ;
  ;
*-----
* Self-Shielding calculation EXCEL
* Transport calculation          EXCEL
* Flux calculation for keff
*-----
VOLMATS INTLINS := NXT: CANDU6S ::

```

```

    TITLE 'TCWU05: CANDU-6 CARTESIAN POWER= 31.971 FUEL TEMP= 941.29'
    EDIT 0 TRAK TISO 5 10.0 ;
LIBRARY := SHI: LIBRARY VOLMATS INTLINS ::
    EDIT 0 ;
VOLMATF INTLINF := NXT: CANDU6F ::
    TITLE 'TCWU05: CANDU-6 CARTESIAN POWER= 31.971 FUEL TEMP= 941.29'
    EDIT 0 TRAK TISO 5 10.0 ;
PIJ := ASM: LIBRARY VOLMATF INTLINF :: ;
FLUX := FLU: PIJ LIBRARY VOLMATF ::
    TYPE K ;
assertS FLUX :: 'K-EFFECTIVE' 1 1.120613 ;
EDITION := EDI: FLUX LIBRARY VOLMATF ::
    COND 4.0 MERGE MIX 0 0 0 0 1 0 0 0 0 0 SAVE ON 'EDITMOD' ;
EDITION := EDI: EDITION FLUX LIBRARY VOLMATF ::
    COND 4.0 MERGE COMP MICR 1 Xe135 SAVE ;
*-----
* Burnup loop: for first step BURNUP is created
* while for other steps it is modified
*-----
WHILE Timei Timec < DO
    EVALUATE Timef := Timei Delt + ;
    IF Timei 0.0 = THEN
        BURNUP LIBRARY := EVO: LIBRARY FLUX VOLMATF ::
            DEPL <<Timei>> <<Timef>> DAY POWR <<Power>> ;
    ELSE
        BURNUP LIBRARY := EVO: BURNUP LIBRARY FLUX VOLMATF ::
            NOEX DEPL <<Timei>> <<Timef>> DAY POWR <<Power>> ;
    ENDIF ;
LIBRARY := SHI: LIBRARY VOLMATS INTLINS ::
    EDIT 0 ;
PIJ := DELETE: PIJ ;
PIJ := ASM: LIBRARY VOLMATF INTLINF :: ;
FLUX := FLU: FLUX PIJ LIBRARY VOLMATF ::
    TYPE K ;
EDITION := EDI: EDITION FLUX LIBRARY VOLMATF ::
    SAVE ;
*-----
* change delta t for burnup and final time if required
*-----
    IF Timef Timec = THEN
        IF Timec 150.0 = THEN
            EVALUATE Delt Timec := 50.0 300.0 ;
        ENDIF ;
        IF Timec 50.0 = THEN
            EVALUATE Delt Timec := 20.0 150.0 ;
        ENDIF ;
        IF Timec 10.0 = THEN
            EVALUATE Delt Timec := 10.0 50.0 ;
        ENDIF ;
        IF Timec 5.0 = THEN
            EVALUATE Delt Timec := 5.0 10.0 ;
        ENDIF ;
        IF Timec 1.0 = THEN
            EVALUATE Delt Timec := 4.0 5.0 ;
        ENDIF ;

```

```

ENDIF ;
EVALUATE Timei := Timef ;
ENDWHILE ;
assertS FLUX :: 'K-EFFECTIVE' 1 0.9537331 ;
*-----
* Save calculation results in CPO format file
*-----
COMPO1 := CPO: BURNUP EDITION ::
  BURNUP REF-CASE EXTRACT Xe135 Xe135  NAME MIXTRXE ;
fuel := COMPO1 ;
COMPO2 := CPO: EDITION ::
  STEP 'EDITMOD' NAME MIXTMOD ;
mode := COMPO2 ;
INTLIN INTLINS := DELETE: INTLIN INTLINS ;
ECHO "test TCWU15 completed" ;
END: ;
QUIT "LIST" .

```

#### 8.5.16 (TCWU17) – A 2-D CANDU-6 supercell with control rods

*Colored by Region*

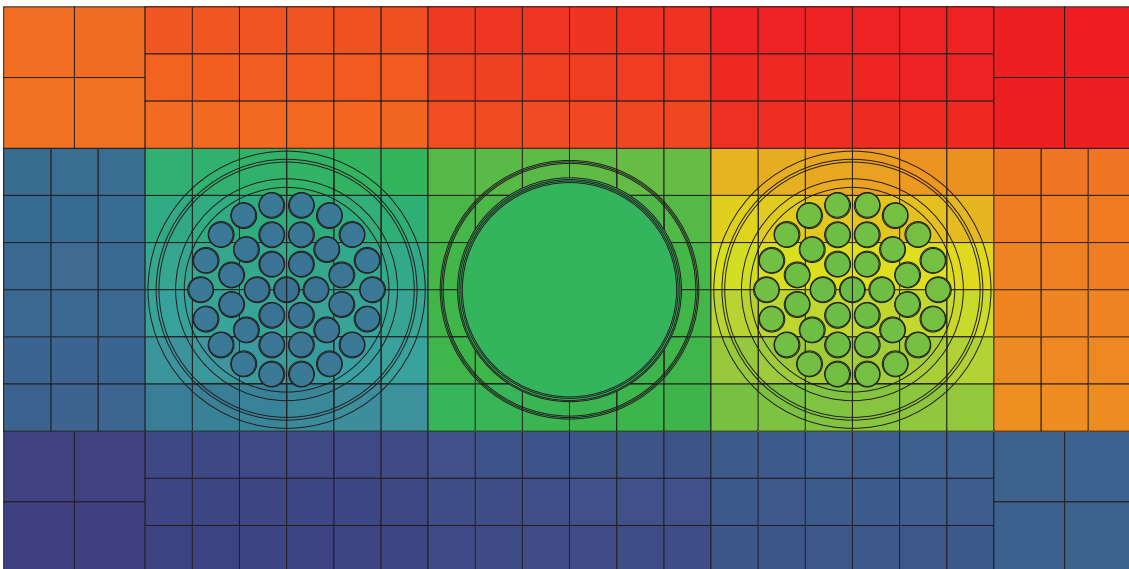

Figure 43: Geometry of 2-D CANDU-6 supercell with control rods.

This test case treats a 2-D CANDU-6 supercell containing fuel clusters and control rods (see Figure 43). The use of the virtual homogenization mixtures defined by HMIX is also illustrated. This test case uses the embedded DRAGON procedure stored in the TCWU17Lib.c2m file.

Input data for test case: **TCWU17.x2m**

```

*-----
* Exemple of the use of HMIX for cell homogenization
* 2-D supercell with fuel clusters based on AECL supercell model
* for G2 SOR and MCA with fuel and reactivity devices parallel

```

```

* References
* PREPARED BY   : G. Marleau on 2013/06/11
*
*-----
* modules and data structures
*-----
SEQ_ASCII      MACROLIBF ;
LINKED_LIST    SORINS SORIN TRACK MicLib FLUX EDITION ;
XSM_FILE       ASMPIJ ;
SEQ_ASCII      FigReg.ps FigMix.ps FigHom.ps ;
SEQ_ASCII      HomMix.txt HomHMix.txt ;
SEQ_BINARY     Lines ;
MODULE         GEO: EXCELT: EXCELL: SHI: ASM: LIB: FLU:
              EDI: UTL: DELETE: FREE: END: INFO: CPO: MAC:
              NXT: PSP: ;
PROCEDURE      TCWU17Lib ;
PROCEDURE      assertS ;
INTEGER        iedit := 1 ;
MicLib := TCWU17Lib :: <<iedit>> ;
*-----
* DEFINE GEOMETRY FOR SUPERCELL CALCULATION
* SORINS : 2D self-shielding geometry with SHUT-OFF ROD & GT in
*         for annular fuel.
* SORIN  : 2D transport geometry with SHUT-OFF ROD & GT in
*         for annular fuel.
*-----
SORINS := GEO: :: CAR2D 5 3
  EDIT 0
  X- REFL X+ REFL
  Y- REFL Y+ REFL
  CELL M    MXL  MX2  MXR  M
        MY  FXYL  BXY  FXYR MY
        M    MXL  MX2  MXR  M
  ::: M := GEO: CAR2D 1 1
    MESHX 0.0    7.14375
    MESHY 0.0    7.14375
    HMIX 0
    MIX 5 ;
  ::: MXL := GEO: CAR2D 2 1
    MESHX -7.14375 0.0 7.14375
    MESHY 0.0    7.14375
    HMIX 0 1
    MIX 5 15 ;
  ::: MX2 := GEO: CAR2D 1 1
    MESHX -7.14375 7.14375
    MESHY 0.0    7.14375
    HMIX 1
    MIX 15 ;
  ::: MXR := GEO: CAR2D 2 1
    MESHX -7.14375 0.0 7.14375
    MESHY 0.0    7.14375
    HMIX 1 0
    MIX 15 5 ;
  ::: MY := GEO: CAR2D 1 2
    MESHY -7.14375 0.0 7.14375

```

```

MESHX 0.0      7.14375
HMIX   0      0
MIX    5      5 ;
::: BXY := GEO: CARCEL 2
MESHX -7.14375 7.14375
MESHY -7.14375 7.14375
RADIUS 0.0 6.380 6.530
HMIX   1      1      1
MIX   15     15     15
CLUSTER ROD
::: ROD := GEO: TUBE 4
  NPIN 1 RPIN 0.0 APIN 0.0
  RADIUS 0.0 5.4115 5.4877 5.5791 5.6553
  HMIX   1      1      1      1
  MIX   15     14     21     14      ;      ;
::: FXYL := GEO: CARCEL 5 2 1
MESHX -7.14375 0.0 7.14375
MESHY -7.14375 7.14375
RADIUS 0.00000 5.16890 5.60320 6.44780 6.58750 7.00
HMIX   0      0      0      0      0      0
      1      1      1      1      1      1
MIX   1      2      3      4      5      5
      11     12     13     14     15     15
CLUSTER ROD1 ROD2L ROD2R ROD3L ROD3R ROD4L ROD4R
::: ROD1 := GEO: TUBE 2 1 2 MIX 6 10 16 20 HMIX 0 0 1 1
  NPIN 1 RPIN 0.0000 APIN 0.0000
  MESHX -0.6540 0.6540
  MESHY -0.6540 0.0 0.6540
  RADIUS 0.00000 0.6122 0.6540 ;
::: ROD2L := GEO: TUBE 2 MIX 7 10 HMIX 0 0
  RADIUS 0.00000 0.6122 0.6540
  NPIN 3 RPIN 1.4885
  APIN 2.09439510 3.14159265 4.18879020 ;
::: ROD2R := GEO: TUBE 2 MIX 17 20 HMIX 1 1
  RADIUS 0.00000 0.6122 0.6540
  NPIN 3 RPIN 1.4885
  APIN -1.04719755 0.0000 1.04719755 ;
::: ROD3L := GEO: TUBE 2 MIX 8 10 HMIX 0 0
  RADIUS 0.00000 0.6122 0.6540
  NPIN 6 RPIN 2.8755
  APIN -2.87979327 -2.35619449 -1.83259571
      1.83259571 2.35619449 2.87979327 ;
::: ROD3R := GEO: TUBE 2 MIX 18 20 HMIX 1 1
  RADIUS 0.00000 0.6122 0.6540
  NPIN 6 RPIN 2.8755
  APIN -1.30899694 -0.78539816 -0.26179939
      0.26179939 0.78539816 1.30899694 ;
::: ROD4L := GEO: TUBE 2 MIX 9 10 HMIX 0 0
  RADIUS 0.00000 0.6122 0.6540
  NPIN 9 RPIN 4.3305
  APIN 1.74532925 2.09439510 2.44346095
      2.79252680 3.14159265 3.49065850
      3.83972435 4.18879020 4.53785606 ;
::: ROD4R := GEO: TUBE 2 MIX 19 20 HMIX 1 1
  RADIUS 0.00000 0.6122 0.6540

```

```

      NPIN  9  RPIN  4.3305
      APIN -1.39626340 -1.04719755 -0.69813170
            -0.34906585  0.0          0.34906585
            0.69813170  1.04719755  1.39626340 ;
;
::: FXR := GEO: CARCEL 5 2 1
  MESHX -7.14375 0.0 7.14375
  MESHY -7.14375 7.14375
  RADIUS 0.00000 5.16890 5.60320 6.44780 6.58750 7.00
  HMIX   1      1      1      1      1      1
        0      0      0      0      0      0
  MIX    11     12     13     14     15     15
        1      2      3      4      5      5
  CLUSTER ROD1 ROD2L ROD2R ROD3L ROD3R ROD4L ROD4R
  ::: ROD1 := GEO: TUBE 2 1 2 MIX 16 20 6 10 HMIX 1 1 0 0
      NPIN  1  RPIN  0.0000  APIN  0.0000
      MESHX -0.6540 0.6540
      MESHY -0.6540 0.0 0.6540
      RADIUS 0.00000 0.6122 0.6540 ;
  ::: ROD2L := GEO: TUBE 2      MIX 17 20 HMIX 1 1
      RADIUS 0.00000 0.6122 0.6540
      NPIN  3  RPIN  1.4885
      APIN  2.09439510 3.14159265 4.18879020 ;
  ::: ROD2R := GEO: TUBE 2      MIX  7 10 HMIX 0 0
      RADIUS 0.00000 0.6122 0.6540
      NPIN  3  RPIN  1.4885
      APIN -1.04719755 0.0000 1.04719755 ;
  ::: ROD3L := GEO: TUBE 2      MIX 18 20 HMIX 1 1
      RADIUS 0.00000 0.6122 0.6540
      NPIN  6  RPIN  2.8755
      APIN -2.87979327 -2.35619449 -1.83259571
            1.83259571  2.35619449  2.87979327 ;
  ::: ROD3R := GEO: TUBE 2      MIX  8 10 HMIX 0 0
      RADIUS 0.00000 0.6122 0.6540
      NPIN  6  RPIN  2.8755
      APIN -1.30899694 -0.78539816 -0.26179939
            0.26179939  0.78539816  1.30899694 ;
  ::: ROD4L := GEO: TUBE 2      MIX 19 20 HMIX 1 1
      RADIUS 0.00000 0.6122 0.6540
      NPIN  9  RPIN  4.3305
      APIN  1.74532925  2.09439510  2.44346095
            2.79252680  3.14159265  3.49065850
            3.83972435  4.18879020  4.53785606 ;
  ::: ROD4R := GEO: TUBE 2      MIX  9 10 HMIX 0 0
      RADIUS 0.00000 0.6122 0.6540
      NPIN  9  RPIN  4.3305
      APIN -1.39626340 -1.04719755 -0.69813170
            -0.34906585  0.0          0.34906585
            0.69813170  1.04719755  1.39626340 ;
;
;
SORIN := GEO: :: CAR2D 5 3
  EDIT 0
  X- REFL X+ REFL
  Y- REFL Y+ REFL

```

```

CELL M    MXL  MX2  MXR  M
      MY  FXYL  BXY  FXYR MY
      M    MXL  MX2  MXR  M
::: M := GEO: CAR2D 1 1
  MESHX 0.0    7.14375  SPLITX 2
  MESHY 0.0    7.14375  SPLITY 2
  HMIX 0
  MIX 5 ;
::: MXL := GEO: CAR2D 2 1
  MESHX -7.14375 0.0 7.14375 SPLITX 3 3
  MESHY 0.0    7.14375  SPLITY 3
  HMIX 0 1
  MIX 5 15 ;
::: MX2 := GEO: CAR2D 1 1
  MESHX -7.14375 7.14375 SPLITX 6
  MESHY 0.0    7.14375  SPLITY 3
  HMIX 1
  MIX 15 ;
::: MXR := GEO: CAR2D 2 1
  MESHX -7.14375 0.0 7.14375 SPLITX 3 3
  MESHY 0.0    7.14375  SPLITY 3
  HMIX 1 0
  MIX 15 5 ;
::: MY := GEO: CAR2D 1 2
  MESHY -7.14375 0.0 7.14375 SPLITY 3 3
  MESHX 0.0    7.14375  SPLITX 3
  HMIX 0 0
  MIX 5 5 ;
::: BXY := GEO: CARCEL 2
  MESHX -7.14375 7.14375 SPLITX 6
  MESHY -7.14375 7.14375 SPLITY 6
  RADIUS 0.0 6.380 6.530
  SPLITR 2 2
  HMIX 1 1 1
  MIX 15 15 15
  CLUSTER ROD
::: ROD := GEO: TUBE 4
  NPIN 1 RPIN 0.0 APIN 0.0
  RADIUS 0.0 5.4115 5.4877 5.5791 5.6553
  SPLITR 1 1 1 1
  HMIX 1 1 1 1
  MIX 15 14 21 14 ; ;
::: FXYL := GEO: CARCEL 5 2 1
  MESHX -7.14375 0.0 7.14375 SPLITX 3 3
  MESHY -7.14375 7.14375 SPLITY 6
  RADIUS 0.00000 5.16890 5.60320 6.44780 6.58750 7.00
  HMIX 0 0 0 0 0 0
      1 1 1 1 1 1
  MIX 1 2 3 4 5 5
      11 12 13 14 15 15
  CLUSTER ROD1 ROD2L ROD2R ROD3L ROD3R ROD4L ROD4R
::: ROD1 := GEO: TUBE 2 1 2 MIX 6 10 16 20 HMIX 0 0 1 1
      NPIN 1 RPIN 0.0000 APIN 0.0000
      MESHX -0.6540 0.6540
      MESHY -0.6540 0.0 0.6540

```

```

RADIUS 0.00000 0.6122 0.6540 ;
::: ROD2L := GEO: TUBE 2      MIX 7 10 HMIX 0 0
RADIUS 0.00000 0.6122 0.6540
NPIN 3 RPIN 1.4885
APIN 2.09439510 3.14159265 4.18879020 ;
::: ROD2R := GEO: TUBE 2      MIX 17 20 HMIX 1 1
RADIUS 0.00000 0.6122 0.6540
NPIN 3 RPIN 1.4885
APIN -1.04719755 0.0000 1.04719755 ;
::: ROD3L := GEO: TUBE 2      MIX 8 10 HMIX 0 0
RADIUS 0.00000 0.6122 0.6540
NPIN 6 RPIN 2.8755
APIN -2.87979327 -2.35619449 -1.83259571
      1.83259571 2.35619449 2.87979327 ;
::: ROD3R := GEO: TUBE 2      MIX 18 20 HMIX 1 1
RADIUS 0.00000 0.6122 0.6540
NPIN 6 RPIN 2.8755
APIN -1.30899694 -0.78539816 -0.26179939
      0.26179939 0.78539816 1.30899694 ;
::: ROD4L := GEO: TUBE 2      MIX 9 10 HMIX 0 0
RADIUS 0.00000 0.6122 0.6540
NPIN 9 RPIN 4.3305
APIN 1.74532925 2.09439510 2.44346095
      2.79252680 3.14159265 3.49065850
      3.83972435 4.18879020 4.53785606 ;
::: ROD4R := GEO: TUBE 2      MIX 19 20 HMIX 1 1
RADIUS 0.00000 0.6122 0.6540
NPIN 9 RPIN 4.3305
APIN -1.39626340 -1.04719755 -0.69813170
      -0.34906585 0.0 0.34906585
      0.69813170 1.04719755 1.39626340 ;
;
::: FXR := GEO: CARCEL 5 2 1
MESHX -7.14375 0.0 7.14375 SPLITX 3 3
MESHY -7.14375 7.14375 SPLITY 6
RADIUS 0.00000 5.16890 5.60320 6.44780 6.58750 7.00
HMIX 1 1 1 1 1 1
      0 0 0 0 0 0
MIX 11 12 13 14 15 15
      1 2 3 4 5 5
CLUSTER ROD1 ROD2L ROD2R ROD3L ROD3R ROD4L ROD4R
::: ROD1 := GEO: TUBE 2 1 2 MIX 16 20 6 10 HMIX 1 1 0 0
NPIN 1 RPIN 0.0000 APIN 0.0000
MESHX -0.6540 0.6540
MESHY -0.6540 0.0 0.6540
RADIUS 0.00000 0.6122 0.6540 ;
::: ROD2L := GEO: TUBE 2      MIX 17 20 HMIX 1 1
RADIUS 0.00000 0.6122 0.6540
NPIN 3 RPIN 1.4885
APIN 2.09439510 3.14159265 4.18879020 ;
::: ROD2R := GEO: TUBE 2      MIX 7 10 HMIX 0 0
RADIUS 0.00000 0.6122 0.6540
NPIN 3 RPIN 1.4885
APIN -1.04719755 0.0000 1.04719755 ;
::: ROD3L := GEO: TUBE 2      MIX 18 20 HMIX 1 1

```



```

        RADIUS 0.00000 0.6122 0.6540
        NPIN 6 RPIN 2.8755
        APIN -2.87979327 -2.35619449 -1.83259571
              1.83259571 2.35619449 2.87979327 ;
::: ROD3R := GEO: TUBE 2 MIX 8 10 HMIX 0 0
        RADIUS 0.00000 0.6122 0.6540
        NPIN 6 RPIN 2.8755
        APIN -1.30899694 -0.78539816 -0.26179939
              0.26179939 0.78539816 1.30899694 ;
::: ROD4L := GEO: TUBE 2 MIX 19 20 HMIX 1 1
        RADIUS 0.00000 0.6122 0.6540
        NPIN 9 RPIN 4.3305
        APIN 1.74532925 2.09439510 2.44346095
              2.79252680 3.14159265 3.49065850
              3.83972435 4.18879020 4.53785606 ;
::: ROD4R := GEO: TUBE 2 MIX 9 10 HMIX 0 0
        RADIUS 0.00000 0.6122 0.6540
        NPIN 9 RPIN 4.3305
        APIN -1.39626340 -1.04719755 -0.69813170
              -0.34906585 0.0 0.34906585
              0.69813170 1.04719755 1.39626340 ;
;
;
*-----
* Rod and GT absent
*-----
TRACK Lines := NXT: SORINS :: EDIT 5 TISO 40 30.0 ;
MicLib := SHI: MicLib TRACK Lines ;
TRACK Lines := DELETE: TRACK Lines ;
TRACK Lines := NXT: SORIN :: EDIT 5 TISO 40 30.0 ;
FigReg.ps := PSP: TRACK :: TYPE REGI ;
FigMix.ps := PSP: TRACK :: TYPE MIXT ;
FigHom.ps := PSP: TRACK :: TYPE HMIX ;
ASMPIJ := ASM: MicLib TRACK Lines :: PIJ ;
FLUX := FLU: ASMPIJ MicLib TRACK :: TYPE K ;
assertS FLUX :: 'K-EFFECTIVE' 1 1.036408 ;
EDITION := EDI: FLUX MicLib TRACK ::
    EDIT 3
    COND 0.625
    MERG HMIX
    SAVE ON SORINHMIX ;
HomHMix.txt := EDITION ;
EDITION := DELETE: EDITION ;
EDITION := EDI: FLUX MicLib TRACK ::
    EDIT 3
    COND 0.625
    MERG MIX 0 0 0 0 0 0 0 0 0 0 1 1 1 1 1 1 1 1 1 1
    SAVE ON SORINMIX ;
HomMix.txt := EDITION ;
EDITION := DELETE: EDITION ;
TRACK FLUX ASMPIJ Lines := DELETE: TRACK FLUX ASMPIJ Lines ;
ECHO "test TCWU17 completed" ;
END: ;
QUIT "LIST" .

```

## 8.5.17 (TCWU17Lib) – Microlib definition.

This CLE-2000 procedure is used in data-set TCWU17 to define the MICROLIB isotopic content.

Input data for test case: **TCWU17Lib.c2m**

```

*-----
* Create Library for test CASE TCWU17.x2m
* Calling :
* LIBRARY := TCWU17Lib.x2m :: iedit ;
* with :
* LIBRARY = Linked list containing the result of LIB: for
* TCWU17.x2m
* iprint = print level for LIB: module
*-----
* Define PARAMETERS,STRUCTURES and MODULES used
*-----
PARAMETER LIBRARY :: LINKED_LIST LIBRARY ; ;
MODULE LIB: DELETE: END: ;
*-----
* Define and read LIB: EDIT option
INTEGER iedit ;
:: >>iedit<< ;
*-----
* Depletion data from file iaea format WIMSD4
* Microscopic cross sections from file iaea format WIMSD4
* All materials are duplicated for left and right cell identification
* during homogenization
*-----
LIBRARY := LIB: ::
EDIT <<iedit>>
NMIX 21 CTRA WIMS
DEPL LIB: WIMSD4 FIL: iaea
MIXS LIB: WIMSD4 FIL: iaea
MIX 1 560.66 0.81212 016 = '6016' 7.99449E-1
D2D20 = '3002' 1.99768E-1 H1H20 = '3001' 7.83774E-4
MIX 2 560.66 6.57 Nb93 = '93' 2.50000
BNat = '1011' 2.10000E-4
Zr91 = '91' 9.75000E+1
MIX 3 345.66 0.0014 He4 = '4' 1.00000E+2
MIX 4 345.66 6.44 Fe56 = '2056' 1.60000E-1
Ni58 = '58' 6.00000E-2 Cr52 = '52' 1.10000E-1
BNat = '1011' 3.10000E-4
Zr91 = '91' 9.97100E+1
MIX 5 345.66 1.082885 016 = '6016' 7.98895E-1
D2D20 = '3002' 2.01016E-1 H1H20 = '3001' 8.96000E-5
MIX 6 941.29 10.4375010 016 = '6016' 1.18473E+1
Xe135 = '4135' 0.0
U235 = '2235' 6.27118E-1 1
U238 = '8238' 8.75256E+1 1
U236 = '236' 0.0 1
Pu239 = '6239' 0.0 1
MIX 7 COMB 6 1.0
MIX 8 COMB 6 1.0
MIX 9 COMB 6 1.0

```

```

MIX 10  560.66  6.44          Fe56  = '2056'  1.60000E-1
        Ni58    = '58'        6.00000E-2  Cr52  = '52'    1.10000E-1
        BNat    = '1011'     3.10000E-4
        Zr91    = '91'        9.97100E+1
MIX 11  560.66  0.81212      O16   = '6016'  7.99449E-1
        D2D20  = '3002'     1.99768E-1  H1H20 = '3001'  7.83774E-4
MIX 12  560.66  6.57          Nb93  = '93'    2.50000
        BNat    = '1011'     2.10000E-4
        Zr91    = '91'        9.75000E+1
MIX 13  345.66  0.0014       He4   = '4'     1.00000E+2
MIX 14  345.66  6.44          Fe56  = '2056'  1.60000E-1
        Ni58    = '58'        6.00000E-2  Cr52  = '52'    1.10000E-1
        BNat    = '1011'     3.10000E-4
        Zr91    = '91'        9.97100E+1
MIX 15  345.66  1.082885     O16   = '6016'  7.98895E-1
        D2D20  = '3002'     2.01016E-1  H1H20 = '3001'  8.96000E-5
MIX 16  941.29  10.4375010    O16   = '6016'  1.18473E+1
        Xe135  = '4135'      0.0
        U235   = '2235'      6.27118E-1  1
        U238   = '8238'      8.75256E+1  1
        U236   = '236'       0.0          1
        Pu239  = '6239'      0.0          1
MIX 17  COMB 6 1.0
MIX 18  COMB 6 1.0
MIX 19  COMB 6 1.0
MIX 20  560.66  6.44          Fe56  = '2056'  1.60000E-1
        Ni58    = '58'        6.00000E-2  Cr52  = '52'    1.10000E-1
        BNat    = '1011'     3.10000E-4
        Zr91    = '91'        9.97100E+1
MIX 21  345.66                Fe56  = '2056'  6.19027E-2
        Cr52    = '52'        1.56659E-3  Ni58  = '58'    6.83337E-3
        Si29    = '29'        7.79072E-4  C12   = '2012'  1.46552E-4
        Mn55    = '55'        1.25431E-3
;
END: ;
QUIT "LIST" .

```

### 8.5.18 (TCWU31) – Compo-based two group burnup of a CANDU-6 type cell.

This case is similar to (TCWU11) except that the two-group burnup calculation recover all its information from a COMPO database. The MICROLIB is defined by the procedure TCWU05Lib.c2m presented in Section 8.5.19.

Input data for test case: **TCWU31.x2m**

```

*-----
* TEST CASE TCWU31
* CANDU-6 ANNULAR CELL
* iaea WLUP Library
* MULTI-PARAMETER COMPO ACCESS FOR MACRO-DEPLETION
* TWO GROUP BURNUP
* POWER (KW)          = 615.00000
* BURN POWER (KW/KG) = 31.97130
* URANIUM MASS       = 19.23600

```

```

* UO2 REAL DENSITY      = 10.59300
* UO2 EFF DENSITY      = 10.43750
* UO2 TEMPERATURE      = 941.28998
* ENRICHMENT           = 0.71140
* COOLANT D2 AT %      = 99.222
* MODERATOR D2 AT %    = 99.911
* NUMBER OF DAYS       = 50
*
*-----
* Define variables
*   Burnup paremeters
*   a) Power
*     = 31.9713 kw/kg for 0.0 to 300.0 days
*   b) 69 Groups Burnup time interval Delt
*     = 300 day for 0 to 300 day
*   c) 2 Groups Burnup time interval Delt
*     = 1 day for 0 to 1 day
*     = 4 days for 1 to 5 days
*     = 5 days for 5 to 10 days
*     = 10 days for 10 to 50 days
*     = 20 days for 50 to 150 days
*     = 50 days for 150 to 300 days
*   c) Days with burnup interval changes
*     = 1.0, 5.0, 10.0, 50.0, 150.0 and 300.0 days
*   d) Burnup control time variables Timei, Timef
*     Timei = initial time
*     Timef = final time
*-----
REAL
  Power    Delt    Timec    Timei Timef :=
  31.9713  1.0    300.0    0.0   0.0 ;
*-----
* Define STRUCTURES and MODULES used
*-----
LINKED_LIST LIBRARY ;
LINKED_LIST
  CANDU6S CANDU6F VOLMATS VOLMATF PIJ FLUX BURNUP EDITION DATABASE ;
SEQ_BINARY
  INTLINS INTLINF ;
SEQ_ASCII
  res ;
MODULE
  GEO: EXCELT: LIB: SHI: ASM: FLU: EVO: EDI: COMPO: SPH: DELETE: END: ;
PROCEDURE assertS ;
*-----
* Depletion data from file iaea format WIMSD4
* Microscopic cross sections from file iaea format WIMSD4
*-----
PROCEDURE TCWU05Lib ;
INTEGER  iedit := 1 ;
LIBRARY := TCWU05Lib :: <<iedit>> ;
*-----
* Geometry CANDU6S : 13 regions annular cluster for self-shielding
*                   CANDU6F : 31 regions annular cluster for transport
*-----

```

```

CANDU6S := GEO: :: TUBE 5
R+ REFL RADIUS 0.00000 5.16890 5.60320 6.44780 6.58750 16.12171
MIX 1 2 3 4 5
CLUSTER ROD1 ROD2 ROD3 ROD4
::: ROD1 := GEO: TUBE 2 MIX 6 10 NPIN 1 RPIN 0.0000 APIN 0.0000
RADIUS 0.00000 0.6122 0.6540 ;
::: ROD2 := GEO: ROD1 MIX 7 10 NPIN 6 RPIN 1.4885 APIN 0.0000 ;
::: ROD3 := GEO: ROD1 MIX 8 10 NPIN 12 RPIN 2.8755 APIN 0.261799 ;
::: ROD4 := GEO: ROD1 MIX 9 10 NPIN 18 RPIN 4.3305 APIN 0.0 ;
;
CANDU6F := GEO: CANDU6S :: SPLITR 6 1 1 1 10
::: ROD1 := GEO: ROD1 SPLITR 2 1 ;
::: ROD2 := GEO: ROD2 SPLITR 2 1 ;
::: ROD3 := GEO: ROD3 SPLITR 2 1 ;
::: ROD4 := GEO: ROD4 SPLITR 2 1 ;
;
*-----
* Self-Shielding calculation EXCEL
* Transport calculation EXCEL
* Flux calculation for keff
*-----
VOLMATS INTLINS := EXCELT: CANDU6S ::
TITLE 'TCWU31: FEW GROUP BURNUP / SELF-SHIELDING TRACKING'
EDIT 0 MAXR 13 TRAK TISO 5 10.0 SYMM 12 ;
LIBRARY := SHI: LIBRARY VOLMATS INTLINS :: EDIT 0 NOLJ ;
VOLMATF INTLINF := EXCELT: CANDU6F ::
TITLE 'TCWU31: FEW GROUP BURNUP / TRANSPORT TRACKING'
EDIT 0 MAXR 31 TRAK TISO 5 10.0 SYMM 12 ;
PIJ := ASM: LIBRARY VOLMATF INTLINF ;
FLUX := FLU: PIJ LIBRARY VOLMATF ::
TYPE K ;
assertS FLUX :: 'K-EFFECTIVE' 1 1.121035 ;
EDITION := EDI: LIBRARY VOLMATF FLUX CANDU6F ::
MERG REGI 6 6 10 7 7 10 1 1 8 8 10 1
1 9 9 10 1 1 2 3 4 5 5 5
5 5 5 5 5 5 5
COND 4.0 MICR ALL SAVE
MGEO CANDU6F
;
EDITION := SPH: EDITION VOLMATF INTLINF ;
FLUX PIJ LIBRARY INTLINS VOLMATS CANDU6S VOLMATF CANDU6F
INTLINF := DELETE: FLUX PIJ LIBRARY INTLINS VOLMATS CANDU6S
VOLMATF CANDU6F INTLINF ;
*-----
* 2 group Burnup (macro-depletion)
*-----
DATABASE := COMPO: ::
EDIT 5
COMM 'Multi-parameter reactor database' ENDC
INIT
;
DATABASE := COMPO: DATABASE EDITION ::
EDIT 3
;
EDITION := DELETE: EDITION ;

```

```

*
* COMPO INTERPOLATION
LIBRARY := SPH: DATABASE ::
  EDIT 1
  STEP UP default STEP AT 1
  MICRO OFF
;
CANDU6F := DATABASE :: STEP UP default STEP UP 'GEOMETRIES' STEP AT 1 ;
VOLMATF INTLINF := EXCELT: CANDU6F ::
  TITLE 'TCWU31: FEW GROUP BURNUP / TRANSPORT TRACKING'
  EDIT 0 MAXR 31 TRAK TISO 5 10.0 SYMM 12 ;
PIJ := ASM: LIBRARY VOLMATF INTLINF ;
FLUX := FLU: PIJ LIBRARY VOLMATF ::
  TYPE K ;
assertS FLUX :: 'K-EFFECTIVE' 1 1.121044 ;
EDITION := EDI: LIBRARY VOLMATF FLUX ::
  EDIT 1 MERGE COMP MICR ALL SAVE ;
EVALUATE Timec := 1.0 ;
WHILE Timei Timec < DO
  EVALUATE Timef := Timei Delt + ;
  IF Timei 0.0 = THEN
    BURNUP LIBRARY := EVO: LIBRARY FLUX VOLMATF ::
      EDIT 3 DEPL <<Timei>> <<Timef>> DAY POWR <<Power>> ;
  ELSE
    BURNUP LIBRARY := EVO: BURNUP LIBRARY FLUX VOLMATF ::
      EDIT 3 NOEX DEPL <<Timei>> <<Timef>> DAY POWR <<Power>> ;
  ENDIF ;
  PIJ := DELETE: PIJ ;
  PIJ := ASM: LIBRARY VOLMATF INTLINF ;
  FLUX := FLU: FLUX PIJ LIBRARY VOLMATF ::
    TYPE K ;
  EDITION := EDI: EDITION LIBRARY VOLMATF FLUX ::
    SAVE ;
*-----
* change delta t for burnup and final time if required
*-----
  IF Timef Timec = THEN
    IF Timec 5.0 = THEN
      EVALUATE Delt Timec := 5.0 10.0 ;
    ENDIF ;
    IF Timec 1.0 = THEN
      EVALUATE Delt Timec := 4.0 5.0 ;
    ENDIF ;
  ENDIF ;
  EVALUATE Timei := Timef ;
ENDWHILE ;
assertS FLUX :: 'K-EFFECTIVE' 1 1.075343 ;
res := EDITION ;
EDITION BURNUP FLUX PIJ LIBRARY INTLINF VOLMATF CANDU6F := DELETE:
  EDITION BURNUP FLUX PIJ LIBRARY INTLINF VOLMATF CANDU6F ;
ECHO "test TCWU31 completed" ;
END: ;
QUIT "LIST" .

```

## 8.5.19 (TCWU05Lib) – Microlib definition.

This CLE-2000 procedure is used in previous data-sets to define the MICROLIB isotopic content.

Input data for test case: **TCWU05Lib.c2m**

```

*-----
* Procedure TCWU05Lib
* Create Library for test CASE TCWU05
* Calling :
*   LIBRARY := TCWU05Lib :: iedit ;
* with :
*   LIBRARY = Linked list containing the result of LIB: for
*             TCWU05
*   iprint = print level for LIB: module
*-----
* Define PARAMETERS,STRUCTURES and MODULES used
*-----
PARAMETER LIBRARY :: LINKED_LIST LIBRARY ; ;
MODULE LIB: END: ;
*-----
* Define and read LIB: EDIT option
INTEGER iedit ;
:: >>iedit<< ;
*-----
* Depletion data from file iaea format WIMSD4
* Microscopic cross sections from file iaea format WIMSD4
*-----
LIBRARY := LIB: ::
  EDIT <<iedit>>
  NMIX 17 CTRA WIMS
  DEPL LIB: WIMSD4 FIL: iaea
  MIXS LIB: WIMSD4 FIL: iaea
  MIX 1 560.66 0.81212 016 = '6016' 7.99449E-1
        D2D20 = '3002' 1.99768E-1 H1H20 = '3001' 7.83774E-4
  MIX 2 560.66 6.57 Nb93 = '93' 2.50000
        BNat = '1011' 2.10000E-4
        Zr91 = '91' 9.75000E+1
  MIX 3 345.66 0.0014 He4 = '4' 1.00000E+2
  MIX 4 345.66 6.44 Fe56 = '2056' 1.60000E-1
        Ni58 = '58' 6.00000E-2 Cr52 = '52' 1.10000E-1
        BNat = '1011' 3.10000E-4
        Zr91 = '91' 9.97100E+1
  MIX 5 345.66 1.082885 016 = '6016' 7.98895E-1
        D2D20 = '3002' 2.01016E-1 H1H20 = '3001' 8.96000E-5
  MIX 6 941.29 10.4375010 016 = '6016' 1.18473E+1
        Xe135 = '4135' 0.0
        U235 = '2235' 6.27118E-1 1
        U238 = '8238' 8.75256E+1 1
        U236 = '236' 0.0 1
        Pu239 = '6239' 0.0 1
  MIX 7 COMB 6 1.0
  MIX 8 COMB 6 1.0
  MIX 9 COMB 6 1.0
  MIX 10 560.66 6.44 Fe56 = '2056' 1.60000E-1

```

```
      Ni58      = '58'      6.00000E-2   Cr52      = '52'      1.10000E-1
      BNat      = '1011'    3.10000E-4
      Zr91      = '91'      9.97100E+1
MIX 11 COMB 10 1.0
MIX 12 COMB 10 1.0
MIX 13 COMB 10 1.0
MIX 14 COMB  1 1.0
MIX 15 COMB  1 1.0
MIX 16 COMB  1 1.0
MIX 17 COMB  1 1.0
;
END: ;
QUIT "LIST" .
```



## 8.6 Depletion chain examples

This test cases show how write a procedure permitting to define a depletion chain in cases where it is not available from the cross-section library. This is the case with APOLLO or MATXS-type libraries. The depletion chain for the heavy isotopes in represented in figure Figure 44.

Input data for test case: **TCDA01.c2m**

```

*-----
* TEST CASE TCDA01
* DEPLETION CHAIN EXAMPLE
*-----
PARAMETER LIBRARY :: :: LINKED_LIST LIBRARY ; ;
MODULE LIB: END: ;
*
LIBRARY := LIB: :: EDIT 2
DEPL 120
CHAIN
U234      922340 NFTOT 191.8 NG 5.2970
           FROM DECAY 1.0 Pu238   N2N 1.0 U235
U235      922350 NFTOT 193.1 NG 6.5452 N2N
           FROM NG 1.0 U234
U236      922360 NFTOT 194.5 NG 5.4984
           FROM NG 1.0 U235
U238      922380 NFTOT 193.8 NG 5.7112 N2N
Np237     932370 NFTOT 196.4 NG 6.3385
           FROM NG 1.0 U236   N2N 1.0 U238
Np239     932390 DECAY 3.39940E+02 NFTOT 196.3 NG 6.7371 N2N
           FROM NG 1.0 U238
Pu238     942380 DECAY 2.50460E-02 NFTOT 197.4 NG 5.6470
           FROM DECAY 1.0 Cm242   NG 1.0 Np237
           N2N 1.0 Pu239 1.0 Np239
Pu239     942390 NFTOT 198.5 NG 6.5336 N2N
           FROM DECAY 1.0 Np239 1.0 Cm243
           NG 1.0 Pu238   N2N 1.0 Pu240
Pu240     942400 NFTOT 199.5 NG 5.2415 N2N
           FROM DECAY 1.0 Cm244   NG 1.0 Pu239
           N2N 1.0 Pu241
Pu241     942410 DECAY 1.52540E-01 NFTOT 202.0 NG 6.3097 N2N
           FROM NG 1.0 Pu240   N2N 1.0 Pu242
Pu242     942420 NFTOT 201.6 NG 5.2562 N2N
           FROM NG 1.0 Pu241 .1416 Am241
Am241     952410 NFTOT 199.0 NG 5.7119
           FROM DECAY 1.0 Pu241
Am242m    952421 DECAY 1.55780E-02 NFTOT 202.3 NG 6.3640
           FROM NG .1150 Am241
Am243     952430 NFTOT 203.6 NG 6.5320
           FROM NG 1.0 Am242m 1.0 Pu242
Cm242     962420 DECAY 4.92360E+00 NFTOT 202.6 NG 5.7010
           FROM NG .7434 Am241
Cm243     962430 DECAY 7.32170E-02 NFTOT 204.0 NG 6.7990
           FROM NG 1.0 Cm242
Cm244     962440 DECAY 1.21350E-01 NFTOT 203.0 NG 5.5200
           FROM NG 1.0 Cm243 1.0 Am243
*
* Fission products are following

```

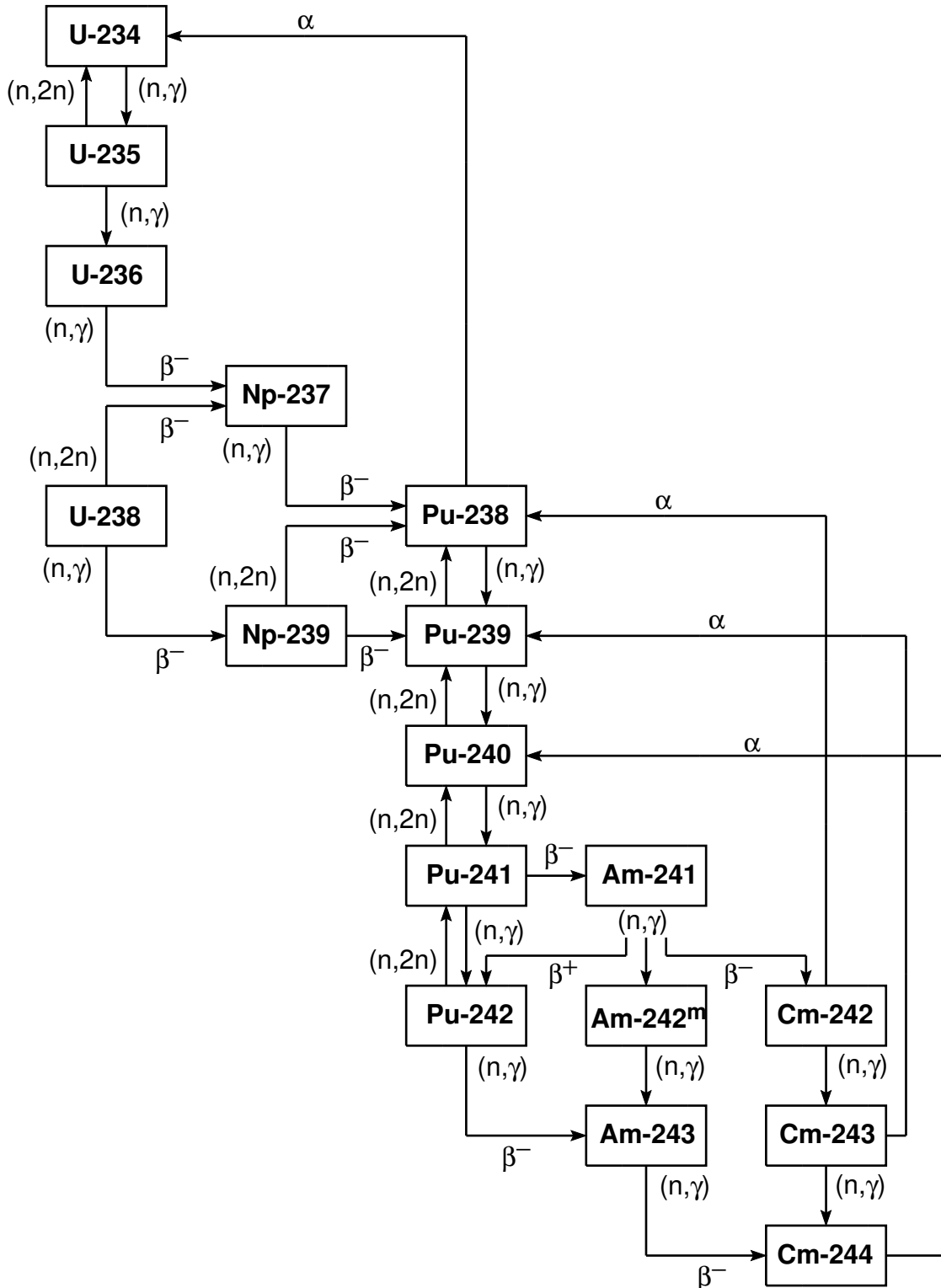

Figure 44: An example of depletion chain.

```
Zr95      400950 DECAY 1.25390E+01 NG  7.8377
FROM NFTOT 6.463E-02 U235      5.113E-02 U238
          4.897E-02 Pu239      4.369E-02 Pu240
```

|      |                           |                  |
|------|---------------------------|------------------|
|      | 3.916E-02 Pu241           | 4.113E-02 Pu242  |
|      | 3.830E-02 Am241           | 3.311E-02 Am242m |
| Zr96 | 400960 NG 5.5751          |                  |
|      | FROM NFTOT 6.248E-02 U235 | 5.977E-02 U238   |
|      | 5.002E-02 Pu239           | 4.941E-02 Pu240  |
|      | 4.376E-02 Pu241           | 4.575E-02 Pu242  |
|      | 4.551E-02 Am241           | 3.630E-02 Am242m |
|      | NG 1.0 Zr95               |                  |

(example truncated)

\*

\* Stable isotopes producing energy are following

|        |                   |
|--------|-------------------|
| Fe54   | NG 9.2990 STABLE  |
| Fe56   | NG 7.6460 STABLE  |
| Fe57   | NG 10.4400 STABLE |
| Fe58   | NG 7.8890 STABLE  |
| Cr50   | NG 9.2930 STABLE  |
| Cr52   | NG 7.9400 STABLE  |
| Cr53   | NG 9.7190 STABLE  |
| Cr54   | NG 7.1830 STABLE  |
| Ni58   | NG 9.0000 STABLE  |
| Ni60   | NG 7.8200 STABLE  |
| Ni61   | NG 10.6000 STABLE |
| Ni62   | NG 6.8423 STABLE  |
| Ni64   | NG 7.1830 STABLE  |
| Mn55   | NG 9.7554 STABLE  |
| H20    | NG 2.2251 STABLE  |
| Zr-nat | NG 8.1395 STABLE  |
| O16    | NG 4.1434 STABLE  |
| Mo95   | NG 9.1540 STABLE  |
| Nb93   | NG 7.2139 STABLE  |
| Ti-nat | NG 8.5137 STABLE  |

ENDCHAIN ;

\*

END: ;

## 8.7 Assert procedures

These two procedures are used in *non-regression testcases* to ensure that existing capabilities of Dragon are not lost with subsequent updates of the code. Procedure `assertS` is used to assert a single real value taken from record `KEY` of a LCM *associative table*. Its calling specification is

Table 139: Structure `assertS`

```
assertS LCMNAM :: KEY ipos value ;
```

where

`LCMNAM`     `character*12` name of the LCM data structure.  
`KEY`         `character*12` name of the real array we want to assert.  
`ipos`        integer index of the component in the real array we want to assert.  
`values`      real reference value of the `ipos`-th component.

Procedure `assertV` is used to assert a single real value taken from an heterogeneous list (named `KEY`) where each component is a real array. Its calling specification is

Table 140: Structure `assertV`

```
assertV LCMNAM :: KEY iset ipos value ;
```

where

`LCMNAM`     `character*12` name of the LCM data structure.  
`KEY`         `character*12` name of the heterogeneous list we want to assert.  
`ipos`        integer index of the component in the heterogeneous list  
`ipos`        integer index of the component in the real array we want to assert.  
`values`      real reference value of the `ipos`-th component.

Input data for test case: `assertS.c2m`

```
*
* Assert procedure for non-regression testing
* Recover a value from a real array
* Author: A. Hebert
*
PARAMETER LCMNAM :: LINKED_LIST LCMNAM ; ;
CHARACTER KEY ;
INTEGER ISET IPOB ;
REAL REFVALUE ;
:: >>KEY<< >>IPOS<< >>REFVALUE<< ;
INTEGER ITYLCM ;
```

```

REAL VALUE DELTA ;
DOUBLE PRECISION DVALUE ;
MODULE GREP: ABORT: END: ;
*
GREP: LCMNAM :: TYPE <<KEY>> >>ITYLCM<< ;
IF ITYLCM 2 = THEN
  GREP: LCMNAM :: GETVAL <<KEY>> <<IPOS>> >>VALUE<< ;
ELSEIF ITYLCM 4 = THEN
  GREP: LCMNAM :: GETVAL <<KEY>> <<IPOS>> >>DVALUE<< ;
  EVALUATE VALUE := DVALUE D_TO_R ;
ELSE
  PRINT "assertS: INVALID TYPE=" ITYLCM ;
  ABORT: ;
ENDIF ;
EVALUATE DELTA := VALUE REFVALUE - REFVALUE / ABS ;
IF DELTA 1.0E-4 < THEN
  PRINT "TEST SUCCESSFUL; DELTA=" DELTA ;
ELSE
  PRINT "-----" ;
  PRINT "TEST FAILURE" ;
  PRINT "-----" ;
  PRINT "REFERENCE=" REFVALUE " CALCULATED=" VALUE ;
  ABORT: ;
ENDIF ;
END: ;

```

Input data for test case: **assertV.c2m**

```

*
* Assert procedure for non-regression testing
* Recover a value from a list of real arrays
* Author: A. Hebert
*
PARAMETER LCMNAM :: :: LINKED_LIST LCMNAM ; ;
CHARACTER KEY ;
INTEGER ISET IPOS ;
REAL REFVALUE ;
:: >>KEY<< >>ISET<< >>IPOS<< >>REFVALUE<< ;
INTEGER ITYLCM ;
REAL VALUE DELTA ;
MODULE GREP: ABORT: END: ;
*
GREP: LCMNAM :: TYPE <<KEY>> >>ITYLCM<< ;
IF ITYLCM 10 = THEN
  GREP: LCMNAM :: STEP UP <<KEY>> GETVAL <<ISET>> <<IPOS>> >>VALUE<< ;
ELSE
  PRINT "assertV: INVALID TYPE=" ITYLCM ;
  ABORT: ;
ENDIF ;
EVALUATE DELTA := VALUE REFVALUE - REFVALUE / ABS ;
IF DELTA 1.0E-4 < THEN
  PRINT "TEST SUCCESSFUL; DELTA=" DELTA ;
ELSE
  PRINT "-----" ;
  PRINT "TEST FAILURE" ;
  PRINT "-----" ;

```

```
PRINT "REFERENCE=" REFVALUE " CALCULATED=" VALUE ;  
ABORT: ;  
ENDIF ;  
END: ;
```

## 9 THE DRAGON PACKAGE

The following archive is required to install DRAGON:

Version5\_evn.tgz

Information is recovered from the archive using

```
tar xvfz Version5_evn.tgz
```

The `tar xvfz` operations will create a directory named `Version5_evn`. Another directory named `libraries` should also be created at the same level to hold cross section libraries. Directory `libraries` is generally a symbolic link to an existing location. The complete setup is depicted in Figure 45.

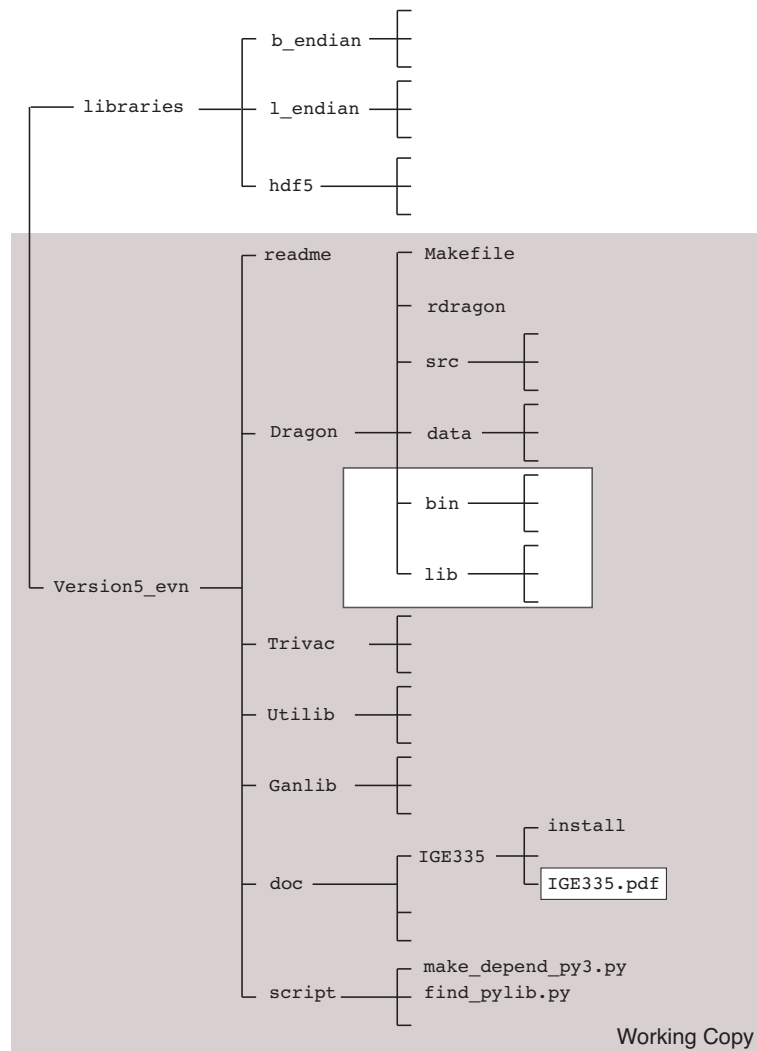

Figure 45: Distribution content.

Directory `Version5` contains the information required to install and configure DRAGON. It is a copy of the *Subversion Working Copy* used by the developers of the code. Inside `Version5_evn` is a file named `readme` that contain the information required to configure DRAGON on your system. This configuration process has the effect to add a few directories and binary files to the `Version5_evn` directory.

Starting with version 5.0.5, it is possible to perform a basic installation on a Unix-based system using makefiles. *Note:* On AIX and Solaris OS, you must replace `make` with `gmake` (the GNU variant of make utility). To install Dragon, simply do

```
cd ~/Version5_evn/Dragon/
make
make clean
```

To build an OpenMP-enabled version, simply write

```
make openmp=1
```

To build an HDF5-enabled version, simply write

```
make hdf5=1
```

To execute the Dragon non-regression tests, do

```
make tests
```

On Windows, Version5 components can be built in two possible ways:

- A native build is possible, provided that *Microsoft Visual Studio* and *Intel Visual Fortran* are available. A script named `instver5.bat` is available to create executables (`.exe`) from a MS-DOS command window. Follow the following steps:
  - Click *Start*, point to *All Programs*, *Intel(R) Software Development Tools*, *Intel(R) Visual Fortran Compiler Professional* and finally *Fortran Build Environment for applications running on IA-32*. The Visual Studio Command Prompt automatically sets the correct paths of both C and Fortran compilers, together with their associated libraries.
  - In the command window, type:
 

```
md %homepath%\Version5_evn\
  \script\instver5
```
- A “Unix-type” build is possible, provided that Cygwin<sup>[124]</sup> or *Windows Subsystem for Linux (WSL)*<sup>[125]</sup> is properly installed on your PC. Cygwin and WSL are native implementations of a *Unix shell*. After installation of Cygwin or WSL, you obtain a native Unix terminal window where all Version5 components can be executed. The DRAGON installation must proceed in the shell.

Directory `libraries` contains open-source Draglibs that can be used to test your implementation. This directory must be installed as shown in Figure 45 *before* following the instructions of the `readme` file for executing multigroup tests. The script named `tdraglib.access` is automatically executed by the `rdragon` script when no other `*.access` script is provided. The `tdraglib.access` script creates a symbolic link between the draglib `draglibJef2p2` and file `DLIB_J2` used in the `tdraglib.x2m` and `trowland.x2m` non-regression tests.

The content of the `readme` file follows:

File: `readme`

```
# Version5 readme

# To activate hdf5 and Python3 bindings in the make utility, you need to define
# environment variables on a UNIX system. Add the information about the HDF5_INC,
# HDF5_API and FORTRANPATH environment variables in the .profile or .bashrc script.
# These lines are OS-dependent.

# Availability of python2 or python3 utility is a prerequisite requirement for using
# Makefiles. Availability of python3 utility and definition of the FORTRANPATH
# environment variable are prerequisite requirements for using the PyGan bindings.

#
# On the recherche network at Polytechnique Montreal:
# Support for HDF5
```



```

export HDF5_INC="/usr/local/hdf5/include" # HDF5 include directory
if [ $MachineExtension = "-aix" ]
then
    export HDF5_INC="/usr/include" # HDF5 include directory
fi
export HDF5_API="$HDF5_INC/./lib" # HDF5 C API
export LD_LIBRARY_PATH="$LD_LIBRARY_PATH:$HDF5_API"
# Support for Python3 API
export FORTRANPATH="/usr/lib/gcc/x86_64-redhat-linux/4.8.5/" # contains libgfortran.so

#
# On the RedHat 8 operating system:
# Support for HDF5
export HDF5_INC="/usr/include" # HDF5 include directory
export HDF5_API="$HDF5_INC/./lib64" # HDF5 C API
export LD_LIBRARY_PATH="$LD_LIBRARY_PATH:$HDF5_API"
# Support for Python3 API
export FORTRANPATH="/usr/lib/gcc/x86_64-redhat-linux/8/" # contains libgfortran.so

#
# On the Ubuntu/arm64 operating system:
# Support for HDF5
export HDF5_INC="/usr/include/hdf5/serial/" # HDF5 include directory
export HDF5_API="/usr/lib/aarch64-linux-gnu/hdf5/serial" # HDF5 C API
export LD_LIBRARY_PATH="$LD_LIBRARY_PATH:$HDF5_API"
# Support for Python3 API
export FORTRANPATH="/usr/lib/gcc/aarch64-linux-gnu/9/" # contains libgfortran.so

#
# On the Scibian 10 operating system:
# Support for HDF5
export HDF5_INC="/usr/include/hdf5/serial" # HDF5 include directory
export HDF5_API="/usr/lib/x86_64-linux-gnu/hdf5/serial" # HDF5 C API
export LD_LIBRARY_PATH="$LD_LIBRARY_PATH:$HDF5_API"
# Support for Python3 API
export FORTRANPATH="/usr/lib/gcc/x86_64-linux-gnu/8/" # contains libgfortran.so

#
# Instructions for configuring Version5 of Dragon/Donjon on UNIX systems
#
# To configure Version5 components with custom compiler using makefiles:
cd ~/Version5_evn/Donjon/
make
make clean
#
# To configure Version5 components with Intel compiler using makefiles:
cd ~/Version5_evn/Donjon/
make intel=1
make clean
#
# To configure Version5 components with Nvidia compiler using makefiles:
cd ~/Version5_evn/Donjon/
make nvidia=1
make clean
#

```

```
# To build an HDF5-enabled version, simply write
make hdf5=1
#
# To build an OpenMP-enabled version, simply write
make openmp=1
#
# To execute the non-regression tests with custom compiler:
make tests
#
# To execute the non-regression tests with Intel compiler:
make tests intel=1
#
# To execute the non-regression tests with Nvidia compiler:
make tests nvidia=1
#
# To execute the non-regression tests, including those requiring hdf5 support:
make tests hdf5=1
#
# On AIX and Solaris OS, you must use GNU Make:
cd ~/Version5_evn/Donjon/
gmake
gmake clean
gmake tests

# To execute Trivac with custom compiler:
cd ~/Version5_evn/Trivac/
./rtrivac iaea3d.x2m

# In case of bug:
./rtrivac -w iaea3d.x2m

# To execute Dragon with custom compiler:
cd ~/Version5_evn/Dragon/
./rdragon iaea2d.x2m

# In case of bug:
./rdragon -w iaea2d.x2m

# To execute Dragon with Intel compiler:
cd ~/Version5_evn/Dragon/
./rdragon -c intel iaea2d.x2m

# To execute Dragon with Nvidia compiler:
cd ~/Version5_evn/Dragon/
./rdragon -c nvidia iaea2d.x2m

# To execute Dragon with Nvidia compiler and 50 OpenMP threads:
cd ~/Version5_evn/Dragon/
./rdragon -c nvidia -p 50 iaea2d.x2m

# To execute Donjon with custom compiler:
cd ~/Version5_evn/Donjon/
./rdonjon Candu6.x2m

# To configure the doc
```

```
cd ~/Version5_evn/doc/IGE335  
./install
```

```
# To read the doc:
```

```
gv -antialias ~/Version5_evn/doc/IGE335/IGE335.pdf
```

## 10 THE GAN GENERALIZED DRIVER

A scientific application can be built around the GAN generalized driver by linking it with application-dependent modules. Such a scientific application will share the following specifications:

1. The GAN generalized driver can handle a custom data type called a *LCM object* and implemented as an *associative table* or *heterogeneous list*. An associative table is a data structure similar to the example shown in Figure 46. An heterogeneous list is an alternative structure where the component are identified by integer values instead of names. Each data type mapped to a LCM object is dynamically allocated using the computer's memory management algorithm and is accessed with a pointer. LCM objects are the *only* memory-resident data type used to transfer information between modules. However, interface files can also be used to transfer information between modules in cases where we want to reduce the memory resource requirements. A LCM object can therefore be declared as `LINKED_LIST` to make it memory-resident or as `XSM_FILE` to make it persistent. Sequential files (either binary or ASCII) can also be used.

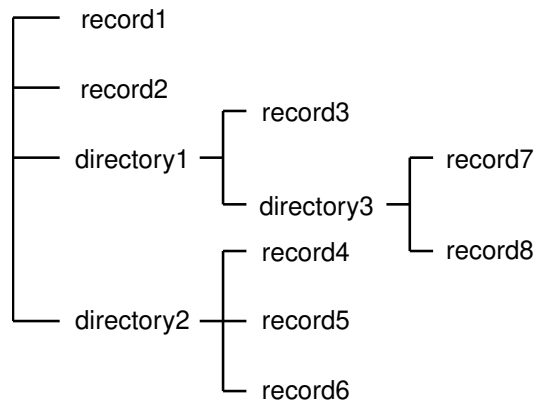

Figure 46: An example of an associative table.

2. Building a scientific application requires the definition of the LCM objects and interface files and the programming of application-dependent modules to manage these LCM objects.
3. A driver was written to support the LCM objects and to read macro-language instructions. The modules are callable from this driver, but the possibility of having “embedded modules”, i.e. modules called directly from a subroutine written in any of these four languages has also been introduced.
4. Utility modules are available to backup the LCM object on an XSM file and to permit code restart.

The modules must be declared in the calling procedure using directives of the form:

Table 141: Structure (`descmodule`)

```
MODULE [[ name ]] ;
```

with

*name* character\*12 symbolic name of a module used in the procedure.

The LCM objects or files must be declared in the calling procedure using directives of the form:

Table 142: Structure (**descobject**)

```
[[ { LINKED_LIST | XSM_FILE | SEQ_ASCII | SEQ_BINARY | HDF5_FILE } [[ name ]] ; ]]
[[ { XSM_FILE | SEQ_ASCII | SEQ_BINARY | HDF5_FILE } name :: FILE path ; ]]
```

with

*name* character\*12 symbolic name of a LCM object (memory-resident or XSM file) or of a sequential file used in the procedure.

**FILE** keyword used to set a file path.

*path* character\*72 path name of a XSM or sequential file used in the procedure. The **FILE** directive is useful to select or create a file anywhere in the directory structure of the computer. It is also useful to tag a created file and avoid its deletion at end of execution.

With this user interface, the input to a module named **MOD:** with two embedded modules **EMB1:** and **EMB2:** will always be of the form:

```
(list of output LCM objects or files) := MOD: (list of input LCM objects or files) :: (data input)
      ::: EMB1: (data input for EMB1:) ;
      ::: EMB2: (data input for EMB2:) ; ;
```

Note that the main use of embedded modules is to define gigogne geometries in module **GEO:**.

The following user's directives are always followed by an application built around the generalized driver:

- An LCM object is resident in core memory if declared as **LINKED\_LIST** in the input data or mapped in a direct access file (of XSM type) if declared as **XSM\_FILE** in the input data.
- All the information declared as **LINKED\_LIST** is destroyed at the end of a run. All other information is located on files which are kept at the end of the run, unless explicitly destroyed by a **DELETE:** command.
- Consider the following example in which the operator **MOD1:** is called with the following command:

```
DATA1 DATA2 := MOD1: DATA4 DATA2 ;
```

Here, **DATA1** is opened in **create** mode because it appears only on the left-hand side (LHS) of the command. **DATA2** is opened in **modification** mode because it appears on both sides of the command. Finally, **DATA4** is opened in **read-only** mode because it appears only on the right-hand side (RHS) of the command.

- The calling sentence to an operator should always end by a “;”. A comment can follow on the same input data record but a carriage return should be performed before other significant data can be read by **REDGET**.
- The possibility of user-defined procedures is also offered. These procedures give the user the possibility to “program” an application using the capabilities of the generalized driver and to use it as a new operator in the main data stream or in a calling procedure.

## 11 THE CLE-2000 CONTROL LANGUAGE

The CLE-2000 control language allows loops, conditional testing and macro-processor capabilities to be included in the generalized driver input deck. A reversed polish notation (RPN) calculator named EVALUATE is also provided. An example of conditional testing is shown in the following example involving two modules:

```

INTEGER INDEX ;
MODULE MOD1: MOD2: ;
.
.
.
EVALUATE INDEX := 0 ;
REPEAT
    EVALUATE INDEX := INDEX 1 + ;
    IF INDEX 3 > THEN
        (list of output objects) := MOD1: (list of input objects) :: (data input for MOD1: ) ;
    ELSE
        (list of output objects) := MOD2: (list of input objects) :: (data input for MOD2: ) ;
    ENDIF ;
UNTIL INDEX 7 >= ;

```

An input deck will be built as a collection of

- PARAMETER, MODULE, PROCEDURE, LINKED\_LIST, XSM\_FILE, SEQ\_BINARY, SEQ\_ASCII, DIRECT\_ACCESS, HDF5\_FILE, INTEGER, REAL, CHARACTER, DOUBLE and LOGICAL declarations;
- MODULE and PROCEDURE calls;
- EVALUATE statements, ECHO statements and conditional logic involving variables.

This type of programming provides the user with much more flexibility than the conventional approaches. It is possible to build new applications without recompilation, simply by changing the order of the module calls and by making modifications to the conditional logic. It is very simple to develop a user-defined function even if this possibility is not programmed into any module.

The CLE-2000 control language brings the following capabilities to any code built around the generalized driver:

- INTEGER, REAL, CHARACTER, DOUBLE and LOGICAL declarations to contain control language and macro-processor variables.
- macro processor variables. For example, it is possible to define a variable VAR1 as equal to a real number and to use <<VAR1>> in place of this real number later on.
- reversed polish notation calculator. A calculator is called each time the statement EVALUATE is used. For example, the statement

```
EVALUATE VAR1 := 4.0 6.0 + ;
```

would assign the result 10.0 to the variable VAR1. Logical operations are fully supported.

- a simple printer. For example, the variable VAR1 can be printed using the command

```
ECHO VAR1 ;
```

- three types of control loops. The available control loops are:
  - IF (*logical expression*) THEN (*user instructions*) ELSE (*user instructions*) ENDIF ;
  - REPEAT (*user instructions*) UNTIL (*logical expression*) ;
  - WHILE (*logical expression*) DO (*user instructions*) ENDWHILE ;

Note that the EVALUATE and ECHO statements are *not* modules of the generalized driver. A few rules and constraints should be known on order to write valid datasets:

- CLE-2000 script files (\*.x2m or \*.c2m) are UNIX ASCII files *not* DOS files.
- A line of CLE-2000 code cannot exceed 132 ASCII characters.
- Only the first 120 ASCII characters are significant.
- All ASCII characters following a “\*” or a “!” are considered as comments.
- All ASCII characters between “(“ and “)” are considered as comments.
- Character case is significant.
- The space character “ ” is the separator. It is obligatory.
- Tab characters are forbidden (you should disable automatic tabs on the editor).
- The main script has a “.x2m” suffix. Called scripts have a “.c2m” suffix.
- If a script is contained in a UNIX file “myscript.x2m” or “myscript.c2m”, its CLE-2000 name is “myscript”. This name cannot exceed 12 characters.

## References

- [1] A. Hébert, *Applied Reactor Physics*, Second Edition, Presses Internationales Polytechnique, ISBN 978-2-553-01698-1, 396 p., Montréal, 2016.
- [2] G. Marleau and A. Hébert, “A New Driver for Collision Probability Transport Codes”, *Int. Top. Mtg. on Advances in Nuclear Engineering Computation and Radiation Shielding*, Santa Fe, New Mexico, April 9–13 (1989).
- [3] G. Marleau, R. Roy and A. Hébert, “DRAGON: A Collision Probability Transport Code for Cell and Supercell Calculations”, Report IGE-157, École Polytechnique de Montréal (1993).
- [4] G. Marleau, A. Hébert and R. Roy, “New Computational Methods Used in the Lattice Code DRAGON”, *Top Mtg. on Advances in Reactor Physics*, Charleston, SC, March 8-11 1992;
- [5] A. Hébert, G. Marleau and R. Roy, “Application of the Lattice Code DRAGON to CANDU Analysis”, *Trans. Am. Nucl. Soc.*, **72**, 335 (1995);
- [6] A. Hébert and R. Roy, “The Ganlib5 kernel guide (64-bit clean version),” Report IGE-332, École Polytechnique de Montréal, January 2013.
- [7] R. Roy, *The CLE-2000 Tool-Box*, Report IGE-163, Institut de génie nucléaire, École Polytechnique de Montréal, Montréal, Québec (1999).
- [8] A. Hoffman et al., “APOLLO: Code Multigroupe de résolution de l’équation du transport pour les neutrons thermiques et rapides”, CEA-N-1610, Commissariat à l’Énergie Atomique, France (1973).
- [9] S. Loubière, R. Sanchez, M. Coste, A. Hébert, Z. Stankovski, C. Van Der Gucht and I. Zmijarevic, “APOLLO2, Twelve Years Later”, *Int. Conf. on Mathematics and Computation, Reactor Physics and Environmental Analysis in Nuclear Applications*, Madrid, Spain, September 27–30, 1999.
- [10] I. Zmijarevic, N. Huot, F. Auffret and P. Bellier, “Description of the APOLLO3 Multi-parameter Output Library for the version AP3-2.0,” DEN/DANS/DM2S/SERMA/LTSD/RT/17-6237/A, Commissariat à l’énergie atomique et aux énergies alternatives (2017).
- [11] P. J. Laughton, “NJOYPREP and WILMAPREP: UNIX-Based Tools for WIMS- AECL Cross-Section Library Production,” Atomic Energy of Canada, Report COG-92-414 (Rev. 0), June 1993.
- [12] A. Hébert, “A Comparison of Three Techniques for Computing Probability Tables”, *Int. Conf. on the Physics of Nuclear Science and Technology*, Long Island, New York, October 5 – 8, 1998.
- [13] A. Hébert and M. Coste, “Computing Moment-Based Probability Tables for Self-Shielding Calculations in Lattice Codes,” *Nucl. Sci. Eng.*, **142**, 245 - 257 (2002).
- [14] A. Hébert, “The Ribon Extended Self-Shielding Model,” *Nucl. Sci. Eng.*, **151**, 1-24 (2005).
- [15] A. Hébert, “Development of the Subgroup Projection Method for Resonance Self-Shielding Calculations,” *Nucl. Sci. Eng.* **162**, 56-75 (2009).
- [16] R. Kondo, T. Endo, A. Yamamoto, S. Takeda, H. Koike, K. Yamaji and D. Sato, “A New Resonance Calculation Method Using Energy Expansion Based on a Reduced Order Model,” *Nucl. Sci. Eng.* **195**, 694-716 (2021).
- [17] B. Dodd, S. Basu, S. Paranjpe and A. Trkov, “WIMS-D Library Update,” International Atomic Energy Agency Report STI/PUB/1264, Vienna, Austria (2007).
- [18] M. Coste *et al.*, “New Improvements in the Self-Shielding Formalism of the APOLLO2 Code”, *Joint Int. Conf. on Mathematical Methods and Supercomputing in Nuclear Applications*, Karlsruhe, Germany, April 19 – 23, 1993.



- [19] A. Hébert, “Développement de la méthode SPH: Homogénéisation de cellules dans un réseau non uniforme et calcul des paramètres de réflecteur”, CEA-N-2209, Commissariat à l’Énergie Atomique, France (1981).
- [20] R. Roy, D. Rozon, A. Hébert and G. Hotte, “Treatment of Circular Boundary Conditions in Neutron Diffusion Calculations”, Third Int. Conf. on Simulation Methods in Nuclear Engineering, Montréal, Canada, April 18 – 20, 1990.
- [21] R. Roy, A. Hébert and G. Marleau, “A Transport Method for Treating Three-Dimensional Lattices of Heterogeneous Cells”, *Nucl. Sci. Eng.*, **101**, 217 (1989).
- [22] R. Roy, G. Marleau, J. Tajmouati and D. Rozon, “Modelling of CANDU Reactivity Control Devices with the Lattice Code DRAGON”, *Ann. nucl. Energy*, **21**, 115 (1994).
- [23] I. R. Suslov, “Solution of Transport Equation in 2- and 3-Dimensional Irregular Geometry by the Method of Characteristics”, *Joint Int. Conf. on Mathematical Methods and Supercomputing in Nuclear Applications*, Karlsruhe, Germany, April 19 – 23, 1993.
- [24] I. R. Suslov, “An Algebraic Collapsing Acceleration Method for Acceleration of the Inner (Scattering) Iterations in Long Characteristics Transport Theory”, *Int. Conf. on Supercomputing in Nuclear Applications*, Paris, France, September 22 – 24, 2003.
- [25] R. Le Tellier and A. Hébert, “Application of the DSA Preconditioned GMRES Formalism to the Method of Characteristics – First Results”, *Int. Mtg. on the Physics of Fuel Cycles and Advanced Nuclear Systems: Global Developments. PHYSOR-2004*, Chicago, Illinois, April 25 – 29, 2004.
- [26] R. Roy, “Anisotropic Scattering for Integral Transport Codes. Part 1. Slab Assemblies”, *Ann. nucl. Energy*, **17**, 379 (1990).
- [27] R. Roy, “Anisotropic Scattering for Integral Transport Codes. Part 2. Cyclic Tracking and its Application to XY Lattices” *Ann. nucl. Energy*, **18**, 511 (1991).
- [28] R. Roy, G. Marleau, A. Hébert and D. Rozon, “A Cyclic Tracking Procedure for Collision Probability Calculations in 2-D Lattices”, *Int. Topical Meeting on Advances in Mathematica, Computation and Reactor Physics*, Pittsburgh, PA, April 28 – May 2, 1991.
- [29] G. Marleau and R. Roy, “Use of Specular Boundary Conditions for CANDU Cell Analysis”, *Fourth Int. Conf. on Simulation Methods in Nuclear Engineering*, Montréal, June 2-4, 1993.
- [30] H. Khalil, “Effectiveness of a Consistently Formulated Diffusion Synthetic Acceleration Differencing approach”, *Nucl. Sci. Eng.*, **98**, 226 (1988).
- [31] S. Moustafa, I. Dutka-Malen, L. Plagne, A. Ponçot and P. Ramet, “Shared memory parallelism for 3D Cartesian discrete ordinates solver,” *Ann. nucl. Energy*, **82**, 179 (2015).
- [32] K. Przybylski and J. Ligou, “Numerical Analysis of the Boltzmann Equation Including Fokker-Planck Terms,” *Nucl. Sci. Eng.*, **81**, 92 (1982).
- [33] Y. Saad and M. H. Schultz, “GMRES: A Generalized Minimal RESidual Algorithm For Solving Nonsymmetric Linear Systems”, *SIAM J. Sci. Stat. Comput.*, **7**, 856-869 (1986).
- [34] E. M. Baker, “Quadruple range quadrature verification and extension,” Los Alamos National Laboratory, Report LA-UR-07-8050, September 2006.
- [35] G. Marleau and A. Hébert, “Solving the Multigroup Transport Equation Using the Power Iteration Method”, *1985 Simulation Symposium on Reactor Dynamics and Plant Control*, Kingston, Ontario, April 22-23, 1985.
- [36] G. Marleau and A. Hébert, “Introduction of an Improved Critical Buckling Search in WIMS”, *1986 Simulation Symposium on Reactor Dynamics and Plant Control*, Hamilton, Ontario, April 21- 22, 1986.

- [37] R.E. Macfarlane, “TRANSX-CTR: A code for Interfacing MATXS Cross-Section Libraries to Nuclear Transport Codes for Fusion Systems Analysis”, LA-9863-MS, Los Alamos Scientific Laboratory, New Mexico (1984).
- [38] J.V. Donnelly, “WIMS-CRNL, A User’s Manual for the Chalk River Version of WIMS”, AECL-8955, Atomic Energy of Canada Limited (1986).
- [39] J.R. Askew et al., “A General Description of the Lattice Code WIMS”, *J. of British Nucl. Energy Soc.*, **5**, 564 (1966).
- [40] R.E. Macfarlane, “TRANSX-2: A Code for Interfacing MATXS Cross-Section Libraries to Nuclear Transport Codes”, LA-12312-MS, Los Alamos Scientific Laboratory, New Mexico (1992).
- [41] A. Hébert, G. Marleau and R. Roy, “A Description of the DRAGON and TRIVAC Version4 Data Structures,” Report IGE-295, École Polytechnique de Montréal, August 2006.
- [42] G. Marleau, “New Geometries Processing in DRAGON: The NXT: Module,” Technical Report IGE-260, École Polytechnique de Montréal (2006).
- [43] B. G. Carlson, “Tables of Equal Weight Quadrature  $EQ_n$  Over the Unit Sphere,” Technical Report LA-4734, Los Alamos Scientific Laboratory (1971).
- [44] G. Longoni, and A. Haghigat, “Development of New Quadrature Sets with the “Ordinate Splitting” Technique,” M&C-2001, American Nuclear Society Topical Meeting in Mathematics and Computations, Salt Lake City, Utah (2001), (Proceedings available on CD-Rom).
- [45] R. Sanchez, L. Mao, and S. Santandrea, “Treatment of Boundary Conditions in Trajectory-Based Deterministic Transport Methods,” *Nucl. Sci. Eng.*, **140**, 23–50 (2002).
- [46] R. Roy, “The Cyclic Characteristics Method”, *Int. Conf. on the Physics of Nuclear Science and Technology*, Long Island, New York, October 5–8, 1998,
- [47] R. Roy, “The Cyclic Characteristics Method with Anisotropic Scattering”, *M& C’99 Mathematics and Computation, Reactor Physics and Environmental Analysis in Nuclear Applications*, Madrid, Spain, September 27–30, 1999,
- [48] A. Leonard and C. T. McDaniel, “Optimal Polar Angles and Weights for the Characteristics Method,” *Trans. Am. Nucl. Soc.*, **73**, 172 (1995).
- [49] R. Le Tellier and A. Hébert, “Anisotropy and Particle Conservation for Trajectory-Based Deterministic Methods,” *Nucl. Sci. Eng.*, **158**, 28–39 (2008).
- [50] M.J. Halsall, *CACTUS, A Characteristics Solution to the Neutron Transport Equation in Complicated Geometries*, Report AEEW-R 1291, Atomic Energy Establishment, Winfrith (1980).
- [51] R. Sanchez, “Renormalized Treatment of the Double Heterogeneity with the Method of Characteristics,” *Int. Mtg. on the Physics of Fuel Cycles and Advanced Nuclear Systems: Global Developments. PHYSOR-2004*, Chicago, Illinois, April 25 – 29, 2004.
- [52] A. Hébert, “A Collision Probability Analysis of the Double-Heterogeneity Problem”, *Nucl. Sci. Eng.*, **115**, 177 (1993).
- [53] D. She, Z. Liu and L. Shi, “An Equivalent Homogenization Method for Treating the Stochastic Media”, *Nucl. Sci. Eng.*, **185**, 351 (2017).
- [54] A. Hoffmann, F. Jeanpierre, A. Kavenoky, M. Livolant and H. Lorain, “APOLLO: Code Multigroupe de Résolution de l’Équation du Transport pour les Neutrons Thermiques et Rapides”, Note CEA-N-1610, Commissariat à l’Énergie Atomique, Saclay, France (1973).
- [55] A. Kavenoky, “Calcul et utilisation des probabilités de première collision pour les milieux hétérogènes à une dimension”, CEA-N-1077, Commissariat à l’Énergie Atomique, France (1969).

- [56] R. Sanchez, “Quelques schémas approximatifs dans la résolution par la méthode des probabilités de collision de l'équation intégrale du transport à deux dimensions”, CEA-N-2165, Commissariat à l'Énergie Atomique, France (1980).
- [57] A. Hébert, “Application of a Dual Variational Formulation to Finite Element Reactor Calculations”, *Ann. nucl. Energy*, **20**, 823 (1993).
- [58] A. Hébert, “TRIVAC, A Modular Diffusion Code for Fuel Management and Design Applications”, *Nucl. J. of Canada*, Vol. 1, No. 4, 325 (1987).
- [59] A. Hébert, “The Search for Superconvergence in Spherical Harmonics Approximations,” *Nucl. Sci. Eng.*, **154**, 134 (2006).
- [60] A. Hébert, “Mixed-dual implementations of the of the simplified  $P_n$  method,” *Ann. nucl. Energy*, **37**, 498 (2010).
- [61] A. Hébert and G. Marleau, “Generalization of the Stamm'ler Method for the Self-Shielding of Resonant Isotopes in Arbitrary Geometries,” *Nucl. Sci. Eng.*, **108**, 230 (1991).
- [62] R. E. MacFarlane and A. C. Kahler, “Methods for Processing ENDF/B-VII with NJOY,” *Nuclear Data Sheets*, **111**, 2739 (2010).
- [63] T. Tone, “A Numerical Study of Heterogeneity Effects in Fast Reactor Critical Assemblies,” *J. Nucl. Sci. Technol.*, **12**[8], 467 (1975).
- [64] A. Hébert, “Revisiting the Stamm'ler Self-Shielding Method,” paper presented at the *25th CNS Annual Conference*, June 6–9, Toronto, 2004.
- [65] H. Saygin and A. Hébert, “A New Self-Shielding Method Based on a Detailed Cross-Section Representation in the Resolved Energy Domain,” *Nucl. Sci. Eng.*, **122**, 276 (1996).
- [66] M. Coste, “Absorption résonnante des noyaux lourds dans les réseaux hétérogènes – I-Formalisme du module d'autoprotection d'APOLLO2,” CEA-N-2746, Commissariat à l'Énergie Atomique, France (1994).
- [67] R. Roy and G. Marleau, “Normalization Techniques for Collision Probability Matrices”, *PHYSOR-90*, Marseille, France, April 23–27, 1990.
- [68] E.A. Vliarino, R.J.J. Stammler, A.A. Ferri and J.J. Casal, “HELIOS: Angularly Dependent Collision Probabilities”, *Nucl. Sci. Eng.*, **112**, 16-31 (1992).
- [69] M. J. Grimstone, J. D. Tullett and G. Rimpault, “Accurate Treatments of Fast Reactor Fuel Assembly Heterogeneity with the ECCO Cell Code”, *Proc. Int. Conf. on the Physics of Reactors: Operation, Design and Computation – PHYSOR 90*, Marseille, France, p. IX:24, April 23-27 (1990).
- [70] G. Rimpault, “Algorithmic Features of the ECCO Cell Code for Treating Heterogeneous Fast Reactor Subassemblies”, *Int. Conf. on Mathematics and Computations, Reactor Physics, and Environmental Analyses*, Portland, Oregon, April 30 – May 4, 1995.
- [71] P. Benoist, J. Mondot and I. Petrovic, ‘Calculational and Experimental Investigations of Void Effect – A Simple Theoretical Model for Space-Dependent Leakage Treatment of Heterogeneous Assemblies’, *Nucl. Sci. Eng.*, **118**, 197 (1994).
- [72] I. Petrovic, P. Benoist and G. Marleau, “A Quasi-Isotropic Reflecting Boundary Condition for the Heterogeneous Leakage Model Tibere”, *Nucl. Sci. Eng.*, **122**, 151 (1996)
- [73] “MATXS7A - 69 Neutron Group Cross Section Library in MATXS”, DLC-117, RSIC Data Library Collection, Oak Ridge National Laboratory (1985).
- [74] J.-D. Kim, J.T. Lee, C.-S. Gil and H.R. Kim, “Generation and Benchmarking of a 69-group Cross Section Library for Thermal Reactor Applications”, *J. of the Korean Nucl. Soc.*, **21** 245 (1989).

- [75] P. Vontobel and S. Pelloni, “New JEF/EFF Based MATXS-Formatted Nuclear Data Libraries”, *Nucl. Sci. Eng.*, **101**, 298 (1989).
- [76] A. Hébert, “A Consistent Technique for the Pin-by-Pin Homogenization of a Pressurized Water Reactor Assembly”, *Nucl. Sci. Eng.*, **113**, 227 (1993).
- [77] A. Hébert and G. Mathonnière, “Development of a Third-Generation *Superhomogénéisation* Method for the Homogenization of a Pressurized Water Reactor Assembly”, *Nucl. Sci. Eng.*, **115**, 129 (1993).
- [78] A. Hébert, “Development of a Second Generation SPH Technique for the Pin-by-Pin Homogenization of a Pressurized Water Reactor Assembly in Hexagonal Geometry”, *Trans. Am. Nucl. Soc.*, **71**, 253 (1994).
- [79] P. Blanc-Tranchant, A. Santamarina, G. Willermoz and A. Hébert, “Definition and Validation of a 2-D Transport Scheme for PWR Control Rod Clusters”, paper presented at the *Int. Conf. on Mathematics and Computation, Reactor Physics and Environmental Analysis in Nuclear Applications*, Madrid, Spain, September 27–30, 1999.
- [80] R. Chambon, “Specifications and User Guide for NAP: module in DRAGON/DONJON VERSION5 (Pin Power Reconstruction module),” Report IGE-345, École Polytechnique de Montréal, Institut de Génie Nucléaire (2014).
- [81] T. Courau, M. Cometto, E. Girardi, D. Couyras and N. Schwartz, “Elements of Validation of Pin-by-Pin Calculations with the Future EDF Calculation Scheme Based on APOLLO2 and COCAGNE Codes,” Proceedings of ICAPP 08, Anaheim, CA USA, June 8–12, 2008.
- [82] W. H. Press, B. P. Flannery, S. A. Teukolsky and W. T. Vetterling, “Numerical Recipes, Second Edition (FORTRAN Version)”, Cambridge University Press, Cambridge (1994).
- [83] G. Marleau, “Fine Mesh 3-D Collision Probability Calculations Using the Lattice Code DRAGON”, *Int. Conf. on the Physics of Nuclear Science and Technology*, Long Island, New York, October 5–8, 1998,
- [84] G. Marleau, “New Geometric Capabilities of DRAGON”, *Nineteenth Annual Conf. of the Canadian Nuclear Society*, Toronto, Ontario, October 18–21, 1998,
- [85] I. Kodeli, “Multidimensional Deterministic Nuclear Data Sensitivity and Uncertainty Code System: Method and Application,” *Nucl. Sci. Eng.*, **138**, 45–66 (2001).
- [86] A. Bidaud, G. Marleau, and E. Nablut, “Nuclear Data Uncertainty Analysis using the coupling of DRAGON with SUSD3D,” M&C 2009, Saratoga Springs, NY (2009).
- [87] P. J. Turinsky, R. M. K. Al-Chalabi, P. Engrand, H. N. Sarsour, F. X. Faure and W. Guo, “NESTLE: Few-group neutron diffusion equation solver utilizing the nodal expansion method for eigenvalue, adjoint, fixed-source steady-state and transient problem,” Electric Power Research Center, North Carolina State University, Raleigh, NC 27695-7909 (1994).
- [88] S. Marguet, *The Physics of Nuclear Reactors*, Springer, 2018.
- [89] K. Koebke, H. Haase, L. Hetzelt, and H.-J. Winter, “Application and Verification of the Simplified Equivalence Theory for Burnup States,” *Nucl. Sci. Eng.*, **92**, 56–65 (1986).
- [90] K. Fröhlicher, V. Salino and A. Hébert, “Investigating fission distribution behavior under various homogenization techniques for asymmetrical fuel assemblies and different reflector equivalence methods,” *Ann. nucl. Energy*, **157**, 1–12 (2021).
- [91] K.E. Kohler, *PostScript for Technical Drawings PSPLOT: A FORTRAN-Callable PostScript Plotting Library User’s Manual*, Technical Report Nova Southeastern University, Oceanographic Center, 8000 North Ocean Drive, Dania, Florida; One can get a feel for the flavor of PSPLOT at <http://www.nova.edu/ocean/> while access to the full psplot library is via anonymous ftp: whitetip.ocean.nova.edu in the directory psplot.

- [92] T.O. Theisen, *Ghostview: An X11 user interface for Ghostscript*, This program is free software under the term of the GNU general public licence as published by the Free Software Foundation.
- [93] MATLAB, *The Language of Technical Computing*, [www.mathworks.com](http://www.mathworks.com) (2006).
- [94] C. Plamondon, *Vérification des lignes d'intégration et illustration des géométries DRAGON*, Technical Report IGE-290, École Polytechnique de Montréal (2006).
- [95] A. Hébert, *Revisiting the Ceschino Interpolation Method*, in *MATLAB – A Ubiquitous Tool for the Practical Engineer*, Clara M. Ionescu (Ed.), InTech Open Access Publisher, ISBN 978-953-307-907-3, Croatia, 2011.
- [96] R. Chambon, *Optimisation de la gestion du combustible dans les réacteurs CANDU refroidis à l'eau légère*, Ph. D. Thesis, École Polytechnique de Montréal (2006).
- [97] R.D. Mosteller, L.D. Eisenhart, R.C. Little, W.J. Eich and J. Chao, "Benchmark Calculations for the Doppler Coefficient of Reactivity", *Nucl. Sci. Eng.*, **107**, 265 (1991).
- [98] Ž. Stankovski, "Refinement of the Substructure Method for Integral Transport Calculations", *Nucl. Sci. Eng.*, **92**, 255 (1986).
- [99] R.T. Akroyd and N.S. Riyait, "Iteration and Extrapolation Methods for the Approximate Solution of the Even-Parity Transport Equation for systems with voids", *Ann. nucl. Energy*, **16**, 1 (1989).
- [100] M. T. Sissaoui, G. Marleau and D. Rozon, "CANDU Reactor Simulations Using the Feedback Model with Actinide Burnup History," *Nucl. Technology*, **125**, 197 (1999).
- [101] C. Kieffer, "Implémentation dans le code DRAGON d'un module de calcul de la masse volumique de l'eau légère et lourde en fonction de la température et de la pression.," Technical Report IGE-315, École Polytechnique de Montréal (2009).
- [102] J. Pye, "Freesteam", (2013), <http://freesteam.sourceforge.net/>.
- [103] B. Garland, "Heavy Water Properties at McMaster University", (2015), <http://www.nuceng.ca/d2o/d2ohome.htm>.
- [104] G. Marleau, "DRAGON Theory Manual Part 1: Collision Probability Calculations," Technical Report IGE-236 Rev. 1, École Polytechnique de Montréal (2001).
- [105] P. Guérin, T. Courau, D. Couyras and E. Girardi, "Équivalence et correction de transport dans COCAGNE," *Compte-Rendu CR-I23/2010/042, SINETICS*, Électricité de France, January 2011.
- [106] A. Hébert, "A Reformulation of the Transport-Transport SPH Equivalence Technique," paper presented at the *7th International Conference on Modelling and Simulation in Nuclear Science and Engineering (7ICMSNSE)*, Ottawa, Canada, October 18-21, 2015.
- [107] M. Grandotto-Bietoli, "AUTOSECOL, un calcul automatique de l'auto-protection des résonances des isotopes lourds," Note CEA-N-1961, Commissariat à l'Énergie Atomique, 1977.
- [108] M. Coste, H. Tellier, P. Ribon, C. Raepsaet and C. Van Der Gucht, "New improvements in the self-shielding formalism of the APOLLO2 code," *Int. Top. Mtg. on mathematical methods and supercomputing in nuclear applications. M&C+SNA*, Karlsruhe, Germany, April 19 – 23, 1993.
- [109] A. Ribes and C. Caremoli, "Salomé platform component model for numerical simulation," *COMP-SAC 07: Proceeding of the 31st Annual International Computer Software and Applications Conference*, pages 553-564, Washington, DC, USA, 2007, IEEE Computer Society. See the website at <http://www.salome-platform.org>.
- [110] R. Sanchez, "TDT, an advanced Integral Transport Method," *Annual Meeting of the American Nuclear Society*, San-Diego, California, June 20-24, 1993.

- [111] N. Lyoussi-Charrat, “Calcul du transport neutronique dans le code APOLLO2 par la méthode des probabilités de collision dans une géométrie cartésienne générale,” Thèse de doctorat, Université de Clermont-Ferrand 2, France, Mars 1994.
- [112] X. Warin, “Notice théorique de la méthode des caractéristiques 2D et du générateur de trajectoires SALT,” Report IGE-329, École Polytechnique de Montréal, Mars 2002.
- [113] A. Hébert, “DRAGON5 and DONJON5, the contribution of École Polytechnique de Montréal to the SALOME platform,” *Ann. nucl. Energy*, **87**, 12–20 (2016).
- [114] D. Tomatis, F. Bidault, A. Bruneton and Z. Stankovski, “Overview of SERMA’s Graphical User Interfaces for Lattice Transport Calculations,” *Energies*, vol. 15, no. 4, 2022.
- [115] G. Harrisson, and G. Marleau, “Modeling of a 3-D SCWR unit cell,” *32nd Annual conference of the CNS*, Niagara Falls, ON (2011).
- [116] C. Laville, *Étude de différentes méthodes de calculs de coefficients de sensibilités du keff aux données nucléaires*, Master Thesis, École Polytechnique de Montréal (2011).
- [117] “SCALE : A Modular Code System for Performing Standardized Computer Analyses for Licensing Evaluation”, Oak Ridge National Laboratory, ORNL/TM-2005/39, Version 6.1 (2011).
- [118] S. Perruchot-Triboulet and R. Sanchez, “Décomposition par méthodes perturbatives de réactivité de deux systèmes,” Note CEA-N-2817, Commissariat à l’Énergie Atomique, France, Février 1997.
- [119] G. Todorova, H. Nishi and J. Ishibashi, “Method for Condensation of the Macroscopic Transport Cross-Sections for Criticality Analyses of FBR MONJU by the Code NSHEX”, *J. of Nucl. Sci. and Tech.*, **41**, No. 12, 1237 (2004).
- [120] J.-F. Vidal, P. Archier, B. Faure, V. Jouault, J.-M. Palau, V. Pascal, G. Rimpault, F. Auffret, L. Graziano, E. Masiello *et al.*, “Apollo3 homogenization techniques for transport core calculations – application to the Astrid CFV core,” *Nucl. Eng. and Technology*, **49**, 1379 (2017).
- [121] J. Leppänen, “Serpent, a Continuous-energy Monte Carlo Reactor Physics Burnup Calculation Code,” VTT Technical Research Centre, Finland, March 2013.
- [122] The HDF Group, <https://www.hdfgroup.org>.
- [123] J.E. Morel, Leonard J. Lorence, Jr., Ronald P. Kensek, John A. Halbleib and D. P. Sloan, “A Hybrid Multigroup/Continuous-Energy Monte Carlo Method for Solving the Boltzmann-Fokker-Planck Equation,” *Nucl. Eng. and Technology*, **124:3**, 369-389 (1996).
- [124] The home of the Cygwin project, <http://www.cygwin.com/>.
- [125] Windows Subsystem for Linux, <https://learn.microsoft.com/en-us/windows/wsl/>.

## Index

- (, 240, 244–246, 248, 252, 256, 259, 261, 262, 264, 267, 269, 273, 274, 277, 279, 280, 283, 284, 286, 290, 294, 297, 300, 302, 304, 305, 308, 311, 314, 316, 319, 326, 327, 331
- \*, 100, 106, 136, 215, 216, 225, 226
- ::, 9, 16, 31, 65, 68, 72, 77, 80, 84, 87, 89, 92, 99, 111, 117, 123, 126, 129, 132, 139, 142, 144, 146, 149, 155, 162, 165, 167, 169, 172, 173, 175, 176, 179, 182, 185, 187, 189, 192, 194, 198, 202, 204, 207, 209, 214, 215, 217, 219–221, 223, 225–227, 229, 232, 233, 336, 345
- :::, 32
- :=, 9, 16, 31, 32, 65, 68, 72, 77, 80, 84, 87, 89, 92, 99, 111, 117, 123, 129, 132, 139, 142, 144, 146, 149, 155, 162, 164, 165, 167, 172, 173, 175, 176, 179, 182, 185, 187, 189, 192, 194, 198, 204, 207, 209, 214, 215, 217, 219–223, 227, 229, 232, 233
- ;, 3, 4, 9, 10, 15, 32, 164, 167, 172, 175, 205, 207, 214, 215, 217, 219–225, 227, 229–233, 336, 344, 345
- =, 25, 215–218
- SALT:, 209, 210
- 2:/dir/rec, 227
- A, 139, 140
- a, 139, 140
- AAC, 77, 78
- (ABORT:), 230
- ABORT:, 230
- ABS, 187, 215, 216
- ABSO, 152
- Absorption, 159
- ACCE, 93, 94
- ACTI, 100, 104, 105
- ACYL, 35, 36
- ADD, 10, 12, 215, 216
- (ADD:), 222
- ADD:, 6, 222
- ADDI, 187
- ADED, 16, 19
- ADF, 13, 15, 100, 106
- adf, 183, 184
- ADF FD\_B, 120, 121
- ADF FD\_H, 121
- ADFM, 100, 106
- ADI, 87, 88
- ADJ, 16, 18, 77, 79
- ADJ\_FLUNAM, 167
- AFM:, 7
- ALAMOS, 205
- ALBE, 35, 36, 183, 184
- ALBE 1.0, 95
- albedo, 35, 36
- albedp, 10, 11
- ALBP, 10, 11, 133, 135
- ALBS, 89, 90, 95–97, 99, 100, 106, 118, 120
- ALL, 50, 59, 100, 104, 105, 146, 147, 195, 196, 199, 200, 233
- ALLG, 68, 69, 72, 73, 80, 81, 210, 211
- ALLREDUCE, 232, 233
- ALLX, 100, 104, 136
- ALSB, 94
- ANG, 35, 37
- ang, 35, 37
- ANIS, 10, 11, 16, 18, 68, 72, 167, 210, 211
- APEX, 118, 122
- APIN, 43, 45
- apin, 63
- apins, 43, 45
- APLIB1, 16, 20, 126, 127
- APLIB2, 16, 20, 24, 126, 127
- APLIB3, 16, 20, 21
- APOL, 10, 11, 16, 18
- apower, 112, 113, 115
- APTRIM, 142
- APXNAM, 117–119, 122
- APXSM, 16, 20, 24
- ARM, 89, 90, 106, 118, 120, 121, 190–193, 195, 196, 199, 200
- ASCII, 100, 105, 139, 173, 174
- ASKE, 65, 67
- (ASM:), 89
- ASM:, 2, 5–7, 69, 73, 74, 89, 94, 96, 97, 106, 120, 211, 212
- ASMPIJ, 2, 7, 89, 92, 99
- assertS, 336
- assertS, 234, 336
- assertV, 336
- assertV, 234, 336
- ASYM, 118, 121
- AT, 118, 119, 214, 215, 220, 221, 225
- ATM%, 126, 127
- (AUTO:), 198
- AUTO:, 5, 6, 189, 198, 202
- AVER, 202
- azimutal, 177
- B, 93, 94, 96, 139, 140
- b, 139–141
- BO, 95, 96, 232
- BOTR, 95, 96
- B1, 95, 96, 172, 232
- B2, 146

- b2*, 100, 107, 118, 122  
**(BACKUP:)**, 220  
 BACKUP:, 6, 220  
*bar*, 126, 127  
 BARRIER, 232, 233  
 BC, 179, 180  
*beg*, 232  
 BELL, 118, 120  
 BFPG, 80, 82  
 BFPL, 80, 82  
 BIHET, 61  
 BINARY, 173  
**(BIVACT:)**, 84  
 BIVACT:, 4, 63, 84  
 BLOCK, 215–217, 225, 226  
 BLOCK2, 217, 218  
**(BREF:)**, 182  
 BREF:, 182  
**(BREF\_data)**, 182, 183  
*BREF\_data*, 182  
 BRNNAM, 111, 112, 114, 132, 134, 136, 146,  
 149, 151, 153, 155, 156, 158, 160  
 BTE, 80, 82  
 BUCK, 95, 97  
*bup*, 142, 143  
 BURN, 17, 21, 115, 142, 143  
*BURNUP*, 173, 174  
 BURNUP, 146, 147, 173, 174  
 BURNUP, 7, 16, 17, 109, 111, 146, 174  
*burnup*, 112, 115  
  
 C, 126, 127, 139, 141  
*c*, 139, 141  
 CACA, 68, 70, 72, 74, 77, 78, 210, 212  
 CACB, 68, 70, 72, 74, 77, 78, 210, 212  
 CALC, 126–128, 195, 196, 199–201  
 CALENDF, 16, 17  
 Capture, 159  
 CaptureEnergyCapture, 159  
 CAR1D, 31, 32, 47, 51, 65, 66, 80, 84  
 CAR2D, 31, 32, 36, 37, 47, 51, 65, 80, 84  
 CAR3D, 31, 32, 36, 37, 47, 52, 80  
 CARCEL, 32, 33, 44, 46, 47, 52, 65, 71, 75  
 CARCELX, 32, 33, 44, 47, 52, 58, 63  
 CARCELY, 32, 33, 44, 47, 53, 58, 63  
 CARCELZ, 32, 33, 44, 47, 53, 63  
 CD, 227  
 CDIRN, 105  
 CELL, 50, 59, 62, 100, 102  
**(CFC:)**, 123  
 CFC:, 7, 123, 124  
 CFCNAM, 123  
**(CHAB:)**, 144  
 CHAB:, 5, 144  
**(CHAB\_data)**, 144  
*CHAB\_data*, 144  
  
 CHAI, 150, 151  
 CHAIN, 23, 24, 112, 114  
 CHAR, 133, 134, 157, 158  
 CHDL, 12, 14  
 CHI, 12, 13, 152, 164  
 CHID, 19  
 CHIS, 19  
**(CLM:)**, 187  
 CLM:, 187  
 CLUSTER, 50, 59, 63  
 CMYK, 185, 186  
 COMB, 25, 27, 308  
 COMM, 133, 134, 150, 157  
*comment*, 150, 157  
 COMP, 100, 101, 106, 119, 120, 162, 163, 165, 166  
 COMPLETE, 35, 37, 59  
**(COMPO:)**, 132  
 COMPO:, 5, 7, 8, 106, 115, 132, 134  
**(compo\_data1)**, 132, 133  
*compo\_data1*, 133  
**(compo\_data2)**, 132, 136  
*compo\_data2*, 133  
**(compo\_data3)**, 132, 137  
*compo\_data3*, 133  
**(compo\_data4)**, 132, 138  
*compo\_data4*, 133  
 CONC, 133, 134, 150, 151, 157  
 COND, 100, 104, 162, 163, 166  
 CONS, 144, 145  
 COOL, 112, 113  
 COPY, 25, 28, 215–217  
 CORN, 68, 71, 72, 75, 211, 213  
 CORR, 25, 26, 152  
 CP, 173, 174, 227  
 CPINX, 43, 45  
 CPINY, 43, 45  
 CPINZ, 43, 45  
 CPO, 7, 123, 146  
**(CPO:)**, 146  
 CPO:, 5, 7, 146  
 CPONAM, 117–119, 123–125, 132–134, 136–138,  
 146, 147  
 CPONEW, 117  
 CPORHS, 132, 133, 137  
 CRE:, 7  
 CREA, 215–217  
 CRON, 152, 153  
 CROWN, 50, 59  
*csum*, 179, 180  
 CTRA, 10, 11, 15, 16, 18, 147, 190, 193, 196, 200  
 CUT, 68, 69, 72, 73, 210, 211  
 CYLI, 35, 36  
  
 D, 139, 141  
*d*, 139, 141  
 D20, 126, 128



- DADJOINTS*, 173  
*DAF*, 173, 174  
*DAY*, 112, 113, 136, 137, 152, 153, 159, 160  
*DB-STRUC*, 138  
*DBYE*, 25, 26  
*dcr*, 23  
*DEBUG*, 229  
*DECAY*, 23, 24  
*DEFAULT*, 100, 102  
*DEL*, 215, 216  
*DELE*, 10, 12, 217  
*(DELETE:)*, 219  
*DELETE:*, 6, 219  
*DELP*, 10, 11  
*DELS*, 100, 105  
*deltaRho*, 169, 170  
*denmix*, 25  
*DENS*, 126–128  
*dens*, 25, 29, 68, 71, 72, 75, 126, 127, 210, 213  
*dens*, 188  
*dens<sub>z</sub>*, 68, 71  
*denscool*, 124, 125  
*densmode*, 124, 125  
*denspr*, 68, 70, 72, 76  
*DEPL*, 16, 20, 21, 105, 112, 114, 115  
*DEPOS*, 179  
*(descasm)*, 89  
*(descauto)*, 198, 199  
*(descBC)*, 32, 34, 35, 94  
*(descbivac)*, 84  
*(descbfc)*, 123, 124  
*(descclm)*, 187  
*(descppo)*, 146  
*(descdepl)*, 16, 17, 21, 23  
*(descdeplA2)*, 16, 17, 21, 24  
*(descDH)*, 32, 34, 61  
*(descedi)*, 99, 100  
*(descevo)*, 111, 112  
*(descexcel)*, 68  
*(descextr)*, 129, 130  
*(descflu)*, 92, 93  
*(descgcnt)*, 31, 32  
*(descgtyp)*, 31, 32  
*(descinfo)*, 126, 128  
*(descleak)*, 93–95  
*(desclib)*, 16, 17, 24, 26, 28  
*(descmac)*, 10  
*(descmacinp)*, 9, 10  
*(descmacupd)*, 9, 10, 15  
*(descmccg)*, 77  
*(descmix1)*, 16, 21, 25, 28  
*(descmix2)*, 17, 21, 29  
*(descmodule)*, 344  
*(descmrg)*, 129, 130  
*(descnxt)*, 72  
*(descobject)*, 345  
*(descPP)*, 32, 34, 48, 50  
*(descpsp)*, 185  
*(descsalt)*, 209–211  
*(descshi)*, 189, 190  
*(descSIJ)*, 32, 34, 62  
*(descsn)*, 80  
*(descSP)*, 32, 34, 43  
*(descsph)*, 117, 118  
*(descsybil)*, 65  
*(desctlm)*, 139  
*(desctone)*, 192  
*(desctrack)*, 64, 65, 68, 72, 80, 84, 87, 209, 210  
*(descTRIVAC)*, 87  
*(descuss)*, 194, 195  
*(descvdg)*, 202  
*(descxs)*, 10, 12, 13  
*DFLUX*, 173  
*DGAU*, 77, 78  
*DIAG*, 35, 50, 69, 73, 77, 78, 89, 90, 95  
*DIAM*, 80, 81  
*DICT*, 215  
*DIFC*, 77, 78  
*DIFF*, 12, 13, 84, 85, 87, 88, 152  
*diff*, 12, 13  
*Diffusion*, 159  
*DIFFX*, 12, 13  
*DIFFY*, 12, 14  
*DIFFZ*, 12, 14  
*dil*, 25  
*DILU*, 199, 200  
*dilut*, 199, 200  
*DIR*, 139, 140, 177, 178, 215, 217  
*dir*, 227  
*DIRA*, 112, 114  
*DIRE*, 100, 106  
*DIRECTIONS*, 139, 140  
*DIRFLX*, 173, 174  
*DIRN*, 100, 105  
*DIRO*, 100, 105  
*DISCR*, 242  
*DIST*, 139, 140  
*dist*, 139, 140  
*disxyz*, 43, 44  
*(DMAC:)*, 165  
*DMAC:*, 5, 165  
*(DMAC\_data)*, 165, 166  
*DMAC\_data*, 165  
*DNAME*, 124  
*DOWN*, 215  
*DPO0*, 65, 66  
*DPO1*, 65, 66  
*DPIN*, 43, 45  
*dpins*, 43, 45  
*DRAGLIB*, 7

- DRAGLIB1*, 144  
*DRAGLIB2*, 144  
**(DRAGON)**, 2, 3  
*DRAGON*, 16, 20, 126, 127  
*DRAWMIX*, 205, 207  
*DRAWNOD*, 205, 207  
**(DRVMPi:)**, 232  
*DRVMPi:*, 232  
*DSA*, 80, 81, 93  
*dTime*, 232, 233  
*DUAL*, 84, 87, 88  
*DUMP*, 215, 216  
**(DUO:)**, 169  
*DUO:*, 5, 169  
**(DUO\_data)**, 169  
*DUO\_data*, 169  
*dvalc*, 215–217  
*dxt*, 112
- ECCO*, 89, 91, 95, 97  
**(EDI:)**, 99  
*EDI:*, 5–7, 19, 50, 99, 132, 136, 147–149, 155, 314  
*EDI\_CURR*, 100, 103  
*EDIAM*, 80, 83  
*EDINA2*, 132, 135  
*EDINAM*, 99, 102, 104, 105, 117, 119, 132, 134–136, 146, 147, 149, 151, 155–157  
*EDINEW*, 117  
*EDIT*, 10, 15–17, 32, 33, 64, 77, 89, 93, 100, 111, 112, 118, 119, 124, 126, 130, 133, 136–139, 142, 144, 146, 150, 152, 153, 157, 159, 160, 162, 165–167, 169, 172–177, 179, 183, 185, 187, 189, 190, 192, 195, 199, 202, 205, 207, 214, 215, 219–221, 225, 227, 232, 233  
*EDIT-SN*, 181–184  
*EDITION*, 173, 174  
*EDITION*, 6, 7, 99, 105, 117, 146, 174  
*EFIS*, 152  
*EGAM*, 152  
*ElasticDiffusion*, 159  
*ElasticScattering*, 159  
*emm*, 80, 83  
*end*, 232  
**(END:)**, 231  
*END:*, 3, 4, 6, 231  
*ENDC*, 133, 134, 150, 195, 196, 199, 201  
*ENDCHAIN*, 23, 24  
*ENDM*, 100  
*ENDMIX*, 142, 143  
*ENDR*, 100, 166  
*ENDREAC*, 169, 170  
*ENDT*, 162, 163  
*ENER*, 10, 11, 152  
*ENERGY*, 169  
*energy*, 10, 11, 23, 24, 100, 104
- ENR:*, 126, 127  
*enrichment*, 126, 127  
*ENTI*, 150, 151  
*EPS*, 190, 192, 193  
*EPS1*, 112, 113  
*EPS2*, 112, 113  
*EPSI*, 77, 78, 80, 82  
*epsi*, 80, 82  
*EPSJ*, 65, 67  
*epsj*, 65, 67  
*epsout*, 93, 94, 118, 121  
*epsthr*, 93, 94  
*epsunk*, 93, 94  
**(equality)**, 214  
*EQUI*, 118, 122, 150, 151, 157, 158  
*EQW*, 65, 66, 72, 74, 75, 210, 212, 213  
*EQW2*, 72, 75, 210, 213  
*ERAS*, 215  
*erravg*, 215, 216  
*errmax*, 215, 216  
*error*, 202, 203  
*ESCHM*, 80, 82  
*eschm*, 80, 83  
*esum*, 179, 180  
*eta*, 177  
**(EVO:)**, 111  
*EVO:*, 5–8, 109–111, 113, 115, 132, 149, 155, 277  
*EVOL*, 25, 27, 29  
*EXCELL*, 100, 102  
*EXCELL:*, 8, 44  
**(EXCELT:)**, 68  
*EXCELT:*, 1, 4–8, 33, 44, 46, 63, 64, 68, 69, 71, 73, 77, 90, 129, 185, 191, 193, 196, 200, 236, 237, 273, 277
- EXPM*, 112, 113  
*EXTE*, 93, 94  
*EXTR*, 112, 114, 130  
*EXTRACT*, 146, 147  
*EXTSTR*, 227
- F**, 93  
*facx1*, 205, 207, 208  
*facx2*, 205, 207, 208  
*facy1*, 205–208  
*facy2*, 205–208  
*false*, 229  
*FBMXSDB*, 7, 123  
*FD\_B*, 106  
*FD\_C*, 106  
*FD\_H*, 106  
*FIL:*, 16, 21, 126, 127  
*FILE*, 345  
*FILL*, 185  
*FIND0*, 229  
**(FINDO:)**, 229  
*FINDO:*, 6, 229

FISS, 150–152, 157, 158  
 Fission, 159  
 FissionEnergyFission, 159  
 FissionSpectrum, 159  
 FIXE, 12, 13  
 FLAT, 195, 196  
 FLOT, 150, 151  
*flott*, 215, 216  
 (FLU:), 92  
 FLU:, 5–8, 92, 95, 109  
 FLUB, 133, 134, 149–151, 156–158  
 FLUDSA, 92, 93  
 FLUG, 133, 134, 150, 151, 157, 158  
 FLUNAM, 92, 93, 95, 99, 106, 111, 114, 117, 118,  
 149, 167, 185  
 FLUX, 165, 173, 174, 176, 177  
 FLUX, 100, 105, 112, 113, 115, 133, 134, 150, 151,  
 157, 158, 185, 186  
 FLUX, 149  
*flux*, 112, 113  
 FLUX-INTG, 12, 14  
 FLUX-INTG-P1, 12, 14  
 FLUX\_FLUX, 112, 114  
 FLUX\_MAC, 112, 114  
 FLUX\_POW, 112, 114  
 FLUXUNK, 7, 92, 99, 111, 174, 244  
*fmac.txt*, 175  
 (FMAC:), 175  
 FMAC:, 175  
 (FMAC\_data), 175  
*FMAC\_data*, 175  
 (FMT:), 173  
 FMT:, 173  
 FOUR, 80, 82  
*fpower*, 112–114  
*fract*, 61  
 FREE, 26  
*freesteam*, 128  
 FROM, 23, 24, 142, 143, 233  
*from*, 233  
*ftrm*, 65, 67, 68, 70, 72, 73, 80, 83, 210, 211  
 FUIT, 152  
 FULL, 77, 79  
  
 G, 95, 97  
 (G2MC:), 207  
 G2MC:, 207  
 (G2MC\_data), 207  
*G2MC\_data*, 207  
 G2S, 99–102  
 (G2S:), 204  
 G2S:, 204  
 (G2S\_data), 204, 205  
*G2S\_data*, 204  
 GAP, 183  
 GAS, 25, 27  
  
 GAUS, 65, 66, 68, 70, 72, 74, 77, 78, 210, 212  
 GC, 190  
 GELB, 89, 90  
 GEO, 100, 101  
 (GEO:), 31  
 GEO:, 2, 4, 6, 31, 32, 63, 64, 102  
 GEOM, 182  
 GEOMLSN, 181, 182  
 GEOMETRY, 6, 31, 65, 68, 72, 77, 80, 84, 87, 99,  
 204, 207, 210  
 GEONAM, 31, 65, 68, 72, 77, 80, 84, 87, 176,  
 185, 204, 207, 209, 210  
 GET, 126, 227  
 GET MASS, 127  
 GETVAL, 225  
 GFF, 133, 135  
*gir*, 25, 26  
 GLOB, 112–115, 146, 147  
 GMRES, 80, 81  
 GOLVER, 100, 103  
 GOXSRN, 10, 12  
 GOXSWN, 10, 11  
 GRAY, 185, 186  
 GREP, 217, 218  
 (GREP:), 225  
 GREP:, 6, 225  
 GRMA, 202  
 GRMAX, 118, 122, 189, 190, 192, 193, 195, 199  
 GRMI, 202  
 GRMIN, 118, 121, 189, 190, 192, 193, 195, 199  
 GROUP, 32, 33  
  
 H-FACTOR, 13, 14  
 H1, 112, 113  
 H2O, 126, 128  
*hadf*, 13, 15  
 HALT, 65, 66, 68, 71  
 HBC, 35  
*HCELL*, 50, 59  
*HCOH*, 25, 26  
*HCOM*, 133, 134  
*hd2*, 126  
 HDD, 77, 79  
 HDF5\_FILE, 345  
 (HEAT:), 179  
 HEAT:, 179  
 (HEAT\_data), 179  
*HEAT\_data*, 179  
 HEBE, 65, 67, 68, 70, 72, 73, 80, 83, 210, 211  
*HEDIT*, 16, 19  
 HELI, 89, 90  
 HETE, 89–91, 95, 97  
 HEX, 32, 33, 44, 45, 47, 53, 65, 84  
 HEXCEL, 32, 33, 44, 46, 47, 54, 65  
*HEXCELZ*, 71  
 HEXCELZ, 32, 33, 44, 48, 55

*hexmsh*, 43, 44, 54–56  
 HEXT, 32, 33, 44, 47, 53  
 HEXTCEL, 32, 33, 44, 48, 54  
 HEXTCELZ, 32, 33, 44, 48, 55  
 HEXTZ, 32, 33, 44, 48, 55  
 HEXZ, 71  
 HEXZ, 32, 33, 44, 45, 48, 54  
*hfact*, 13, 14  
 HINC, 25, 26  
 HISO, 100, 104  
 HISO1, 133, 134  
 HISO2, 133, 134  
 HISOP, 133, 135  
 HISOT, 144, 145  
 HMIC, 133, 134, 149, 151, 155, 156, 158  
 HMIC1, 132, 133, 149, 155, 156  
 HMIC2, 132, 133, 149, 155, 156  
 HMIX, 50, 59, 100, 102, 319  
*hmix*, 142, 143  
*hmod*, 183  
 HNAISO, 150, 151, 157, 158  
 HNAMAC, 150, 151  
 HNAMIX, 150, 152  
 HNAREA, 150, 152, 157, 159  
 HOMO, 118, 119  
 HOMOGE, 31, 32, 65  
 HREAC, 100, 104  
 HSB, 185, 186  
 HTURN, 50, 59  
*htype*, 175–177  
*hu8*, 126  
 (HUTL:), 217  
 HUTL:, 6, 217  
*hvalc*, 215–217  
 HYPE, 183  
  
*i*, 59  
*iac*, 77–79  
*ialter*, 199, 200  
*iburn*, 17, 21  
*ic*, 50, 59  
*icl1*, 80, 81  
*icl2*, 80, 81  
*icode*, 35, 36  
*icol*, 84, 85, 87, 88  
*icond*, 100, 104, 162, 163, 166  
*idclm*, 187  
 IDEM, 95, 98, 118, 119  
*idir*, 139, 140  
*idirn*, 100, 105  
*idirn*, 105  
*idiro*, 100, 105  
 IDX, 172  
*idx*, 172  
*ielem*, 84, 85, 87, 88  
*iext*, 130  
  
*iFrom*, 233  
*ig*, 177  
*igap*, 183  
*igm*, 144, 145  
*igmax*, 183  
*igp*, 144, 145  
*igrp1*, 202  
*igrp2*, 202  
*ihmix*, 50  
*ii*, 101, 163, 166  
*ikryl*, 77, 79  
*ikz*, 162, 163  
*ilastg*, 13, 14  
*ilcm*, 227  
*ilcm1*, 227  
*ilcm2*, 227  
*ilenc1*, 215–218  
*ilenc2*, 215–217  
*ileni*, 215, 216  
*ilev*, 190, 191  
*ilong*, 225  
 ILUO, 77, 79  
*imat*, 10, 12  
*imax*, 195, 196  
*imcu*, 77, 79  
*imerge*, 50, 59  
*imergl*, 95, 98  
*imil*, 150, 151, 157, 158  
*imix*, 50–53, 58, 100, 106, 133, 134, 150, 157, 183,  
 195, 196, 199, 200  
*imix2*, 100, 102  
*imixa*, 100, 104  
*imixm*, 100, 101, 162, 163, 166  
*imixm(ii)*, 101, 163, 166  
*imixold*, 142, 143  
*imixt*, 100, 103  
 IMPR, 215, 217  
*impv*, 87, 88  
*imxit*, 190, 192, 193  
*increment*, 227, 228  
*index*, 118, 119, 214, 215, 220, 221, 225  
*index1*, 225, 226  
*index2*, 225, 226  
*index3*, 225, 226  
*indexfirst*, 227  
 INDMAX, 225, 226  
 INDMIN, 225, 226  
 InelasticDiffusion, 159  
 InelasticScattering, 159  
 INF, 25  
 INFO, 217  
 (info), 126  
 (INFO:), 126  
 INFO:, 5, 126, 128, 308  
 INFOR, 124

- INIT, 93, 133, 135  
 INPUT, 10, 12  
 inrs, 25, 26, 189, 192, 194, 198, 200  
 int, 177  
 INTE, 133, 135, 157, 158  
 INTG, 177, 202, 203  
 INTR, 16, 17, 19  
 ipass, 195, 199, 200  
 iplan, 50, 58, 139, 140  
 iplan1, 50, 58  
 iplot, 139  
 ipos, 336  
 ipreci, 16, 18  
 iprint, 3, 10, 15–17, 20, 21, 32–34, 64, 77, 89, 93,  
     100, 111, 112, 115, 118, 119, 124, 126,  
     130, 133, 136–139, 142, 144, 146, 150,  
     152, 153, 157, 159, 160, 162, 165–167,  
     169, 172–177, 179, 183, 185, 187, 189,  
     190, 192, 193, 195, 199, 202, 205, 207,  
     214, 215, 219–221, 225, 227, 232, 233  
 iqua1, 65, 66  
 iqua2, 65, 66  
 iquab, 65, 67–69, 72, 73, 80, 83, 210, 211  
 iquad, 80, 82  
 ireg, 100, 106  
 iregm, 100, 101, 162, 163, 166  
 iregt, 100, 102  
 irmrg, 130  
 IRR, 133, 134, 149–151, 156, 157  
 IRSET, 25, 26, 190  
 iscat, 80, 81, 84, 85, 87, 88  
 ischm, 80, 81, 83  
 iscr, 77, 79  
 isect, 43, 44  
 iseed, 162, 163, 199, 200  
 iseg, 87, 88  
 iset, 336  
 ismrg, 130  
 ISO, 176, 177  
 ISO:, 126, 127  
 ISONAM, 126, 127  
 isonam1, 150, 157  
 isonam2, 150, 151, 157  
 ISOP, 173, 174  
 ISOT, 133, 135, 150, 151, 157, 158  
 isot, 195, 196, 199, 200  
 isot, 188  
 isot\_d, 199, 200  
 ISOTOPE, 169  
 ISOTXS, 100, 105  
 isplth, 43, 45  
 ispltl, 43, 45  
 ispltr, 43, 44, 58  
 ispltx, 43, 58  
 isplty, 43, 58  
 ispltz, 43, 44, 58  
 istep, 10, 12  
 istis, 77, 79  
 isymm, 68, 71, 72, 74  
 ITEM, 233  
 ITER, 118, 121  
 ITMAX, 229  
 itmax, 229  
 iTo, 233  
 itype, 225  
 iuv, 139, 140  
 ivalc, 215–217  
 iza, 23  
 JAVAPENO, 167  
 jmix, 50, 59  
 JOUT, 100, 106  
 jssect, 43, 44  
 JSURF, 133, 135  
 K, 93, 126, 127  
 KAPS, 112, 113  
 KCODE, 162, 163  
 kct, 162, 163  
 KEEP, 112–114  
 KEFF, 95, 98  
 KERN, 199, 200  
 KEY, 336  
 kPa, 126, 127  
 KRYL, 77, 79  
 L, 93, 94  
 L0, 229  
 lc, 50, 59  
 LCM, 68, 70, 72, 74, 77, 78, 210, 212  
 LCMNAM, 336  
 LDC, 77, 79  
 LEAK, 10, 11, 16, 18, 100, 107, 118, 122  
 len, 232  
 LENGTH, 225  
 LEVEL, 190  
 LEXA, 77, 78  
 LEXF, 77, 79  
 lFlag, 229  
 lgrmax, 118, 122, 189, 190, 192, 193, 195, 199  
 lgrmin, 118, 122, 189, 190, 192, 193, 195, 199  
 lh, 32, 33  
 (LIB:), 16  
 LIB:, 4, 6, 8, 16, 20, 113, 115, 126, 127, 147, 164,  
     190, 194, 198–200, 240, 277, 308  
 LIBNAM, 89, 92, 95, 98, 99, 106, 117, 118  
 LIBNEW, 117  
 LIBRARY, 164  
 LIBRARY, 242  
 LIGN, 65, 67  
 LINKED\_LIST, 3, 345

LIST, 215  
 LIV0, 80, 81  
 LJ, 190  
 LKRD, 95  
 LOCA, 133, 134, 146, 147, 150, 157  
 LOCNAM, 118, 122  
 LONG, 72, 76, 139, 211, 213  
*lp*, 32, 33, 50, 58, 62  
*lr*, 31-33, 43, 44  
 LSN, 72, 75, 210, 212  
 LUMP, 87, 88  
*lx*, 31-33, 43  
*ly*, 31-33, 43  
*lz*, 31-33, 43  
  
*m*, 80, 81  
 m-file, 139  
 (M2T:), 142  
 M2T:, 5, 142  
 (M2T\_data), 142  
 M2T\_data, 142  
 (MAC:), 9  
 MAC:, 4, 6, 9, 12, 36, 147, 164, 244  
 MACGEO, 100, 106  
 MACLIB, 9-11, 15  
 MACLIB1, 164  
 MACLIB2, 164  
 MACNAM, 117, 118  
 MACNEW, 117  
 MACR, 16, 17, 19, 150, 151  
 MACRO, 162, 165, 167, 168, 172, 175, 176, 179,  
 182, 184  
 MACRO, 118, 119, 132, 136  
 MACROGEO, 99, 101  
 MACROLIB, 4-7, 9-12, 15, 16, 89, 92, 93, 99, 105,  
 111, 117, 118, 164, 189, 243  
 MASL, 133, 134, 150, 151, 157, 158  
 MASS, 126  
*mass*, 126, 127  
*mati*, 25, 27  
 MATLAB, 173, 174  
*matlab.m*, 172  
*matnum*, 12-14, 25, 27-29  
*matold*, 29  
 MATXS, 16, 18-20, 26, 126, 127  
 MATXS2, 16, 18-20, 26, 126, 127  
 MATXS7A, 240  
 MAX, 232  
 MAXCAL, 133, 134  
*maxcal*, 133, 134  
*maxcur*, 65, 66  
 MAXI, 77-80, 82  
*maxi*, 80, 82  
*maxint*, 65, 66  
 MAXJ, 65  
*maxmix*, 50, 58, 61, 101, 103, 104, 163, 166  
 MAXNB, 118, 121  
*maxnb*, 118, 121  
*maxout*, 93, 94, 118, 121  
*maxpts*, 100, 106  
 MAXR, 64, 100, 105  
*maxreg*, 45, 49, 62, 64, 66, 101, 102, 163, 166  
 MAXS, 17, 21  
 MAXST, 195, 196  
 MAXT, 199, 200  
*maxthr*, 93, 94  
*maxtra*, 199, 200  
 MAXV, 202  
 MAXVAL, 225  
 MAXZ, 65, 66  
 MC, 72, 75, 162  
 (MC:), 162  
 MC:, 5, 162  
 (MC\_data), 162  
 MC\_data, 162  
 (MCCGT:), 77  
 MCCGT:, 1, 4, 6, 7, 63, 70, 76, 77, 90, 106, 191,  
 193, 196, 200, 264, 267  
 MCFD, 84, 87, 88  
 MCFIL, 207  
 MCU, 77, 79  
 MCU:, 273  
*mdsa*, 80, 82  
 MEAN, 225, 226  
 MEDI, 68, 71, 72, 75, 210, 212  
 MERG, 95, 98, 100-102, 105, 106, 119, 120, 162,  
 163, 165, 166  
 MERGE, 50, 59, 279  
 MERGMIX, 211, 213  
 MESHX, 43, 237  
 MESHY, 43, 237  
 MESHZ, 43  
 MFILE, 139, 173, 174  
 MGEO, 100, 106  
 MGFLUX, 185, 186  
 MICLIB, 9, 16, 17, 21, 28, 29, 187, 189, 192,  
 194-196, 198-200  
 MICLIB1, 169, 202  
 MICLIB2, 169, 202  
 MICLIB\_SG, 194, 198, 199  
 MICNAM, 111, 114  
 MICNAM, 112  
*micnam*, 150, 157  
 MICR, 100, 104, 105, 147  
 MICRO, 162, 165, 176  
 MICRO, 118, 119  
 MICRO1, 144  
 MICRO2, 144  
 MICROLIB, 16, 21, 28, 115  
 MICROLIB, 4-7, 9, 15-18, 89, 92, 93, 99, 111,  
 117, 118, 132-134, 149-151, 155-158,

- 164, 187, 189, 192, 194, 195, 199, 202
- MILI, 150, 151, 157, 158
- milie*, 61
- MIN, 232
- MINVAL, 225
- MIX, 12, 13, 15, 25, 29, 50, 58, 100–103, 142, 162, 163, 166, 183
- MIX-NAMES, 50, 60
- MIXB, 112, 114
- mixbrn*, 112, 114
- MIXCLM, 187
- mixdil*, 61
- mixgr*, 61
- MIXP, 112, 114
- mixpwr*, 112, 114
- MIXS, 16, 17, 20, 21
- mixs*, 118, 121
- MIXTURE, 139, 169, 185, 186
- MLIB, 142
- mm*, 80, 81, 83
- MOCC:, 8, 311
- MODE, 183
- MODI, 144
- MODNAME, 3
- MODULE, 3, 344
- (**module**), 3, 4
- MONO, 176–178
- MOSTELA, 242
- MOSTELC, 242
- MPa, 126, 127
- MPIM, 80, 81
- MPO, 118, 119, 122
- (**MPO:**), 155
- MPO:, 5, 155, 157
- (**mpo\_data1**), 155, 157
- mpo\_data1*, 156
- (**mpo\_data2**), 155, 159
- mpo\_data2*, 156
- (**mpo\_data3**), 155, 160
- mpo\_data3*, 156
- MPONAM, 155, 156, 160
- MPORHS, 155, 156, 160
- (**MPX:**), 223
- MPX:, 6, 223
- MRG:, 129
- (**MSTR:**), 227
- MSTR:, 227
- MT103, 159
- MT104, 159
- MT105, 159
- MT107, 159
- MT108, 159
- MT16, 159
- MT17, 159
- MT28, 159
- MT37, 159
- mu*, 177
- mu/eta/xi*, 178
- MULT, 144, 145, 215, 216
- MULTICOMPO, 5, 7, 117, 118, 122
- MXIS, 16, 17
- MXIT, 190, 192, 193
- MY-ID, 232
- N, 93
- n*, 80, 81, 84, 85, 87, 88
- N2N, 19, 23, 162, 163
- N2NF, 19
- N3N, 19, 23
- N3NF, 19
- N4N, 19, 23
- NA, 19, 24, 152
- naccel*, 93, 94
- NADF, 10, 11, 100, 106
- nadf*, 10, 11, 15
- nadi*, 87, 88
- nalbp*, 10, 11
- NAMALI, 25, 29
- NAMDIR, 133, 134, 136–138, 159, 160
- NAMDPL, 23, 24
- NAME, 232, 233
- NAME, 146, 147, 150, 152
- name*, 344, 345
- NAME1, 20, 21, 214, 215, 217, 219–224, 229, 233
- NAME2, 20, 21, 214, 217, 218, 220–224, 229, 232, 233
- NAME3, 20, 21, 222, 225, 229
- NAMEFIL, 16, 20, 21, 28, 126, 127
- NAMISO, 25, 26, 29
- NAMISO, 173, 174
- NAMMIX, 50, 60
- NAMPAR, 23, 24
- NAMPIN, 50, 59
- NAMS, 25, 26
- NAN, 215
- nanl*, 68, 70–72, 74, 75, 78, 210, 212, 213
- nanl\_z*, 68, 71
- nanis*, 68, 72, 167, 168, 210, 211
- naniso*, 10, 11, 13, 16, 18, 167, 234
- NBAL, 100, 105
- NBC, 179, 180
- nbelem*, 227
- nbiso*, 126, 127
- nbmix*, 98, 179, 180
- nbscat*, 13, 14
- nbsl*, 76, 213
- NBSLIN, 72, 75, 211, 213
- nbslin*, 72, 211
- ncpu*, 232
- NCR:, 8
- nd2*, 128

NDAS, 16, 20, 21, 126, 127  
*ndel*, 10–12  
*ndepl*, 16, 21  
 NDIR, 146, 147  
 NDSA, 80, 82  
*ndsas*, 80, 82  
*nedit*, 16, 19  
 NELAS, 19  
*neval*, 225, 226  
 NEW, 215  
 NEWL, 16, 17, 19  
 NEWNAME, 146, 147  
 Nexcess, 159  
 NF, 19  
*nfou*, 80, 82  
 NFSLO, 19  
 NFTOT, 12, 14, 19, 24  
*nftot*, 12, 14  
 NG, 19, 23  
*ng*, 177  
*ngcond*, 118, 119  
 NGET, 183, 184  
 NGRO, 10, 16  
*ngroup*, 10–13, 16, 94, 104, 163, 166, 234  
*ngroup+1*, 104  
*nh1*, 126, 128  
 NHEAT, 19  
*nhom*, 100, 101  
*nhr*, 32, 33, 44, 45  
 NIFI, 10  
*nifiss*, 10–12  
 NINEL, 19  
*nir*, 25, 27  
*nis*, 100, 104  
*nisp*, 133, 135  
*nl*, 142  
*nlibre*, 93, 94  
 NLIVO, 80, 81  
*nmaxi*, 77, 78  
*nmerge*, 118, 119  
*nmilg*, 61  
*nmisot*, 16, 17  
*nmistr*, 61  
 NMIX, 10, 15–17  
*nmix*, 104, 195, 196, 199, 200  
*nmixt*, 10, 12, 13, 15–17, 25  
*nmu*, 68, 70, 72, 74, 77, 78, 210, 212  
 NNF, 19  
*no16*, 126, 128  
 NOAL, 183, 184  
 NOALBP, 133, 135  
 NOCO, 195  
 NOCONTOUR, 185, 186  
 NODI, 112, 114  
 NOEV, 25, 27, 29  
 NOEX, 112, 114  
 NOGAS, 25, 27  
 NOGC, 190  
 NOGL, 112, 114  
 NOHF, 100, 105  
 NOJSURF, 133, 135  
 NOLJ, 190  
 NOMA, 142  
 NOMALT, 215, 216  
 NOMDIR, 118, 119, 146, 147, 214, 215, 220, 221, 225  
 NOML, 150  
*nomlib*, 150  
 NOMREF, 215, 216  
 non-regression testcases, 234, 336  
 NONE, 10, 11, 16, 18, 25, 27, 77, 78, 89, 90, 100, 101, 104, 162, 163, 165, 166, 185  
 NONL, 89, 90  
 NoPause, 139, 140  
 NORE, 64  
 NORM, 10, 12, 69, 74, 89, 90, 94, 179, 180, 212  
 NOSA, 112  
 NOSP, 183, 184, 192, 193, 195, 196, 199, 200  
 NOSY, 68, 71, 72, 74  
 NOTR, 72, 75, 146, 190, 192, 193, 195, 196, 199, 200, 211, 213  
 NP, 19, 23, 152  
 NPIN, 43, 45  
*npins*, 43, 45, 48  
*nplots*, 139, 140  
*nrads*, 35, 37  
*nreac*, 100, 104  
*nreg*, 130  
*ns*, 61  
 NSAT, 112, 114  
*nsdsa*, 82  
*nsegment*, 65, 66  
 NSHT, 80, 82  
*nsize*, 215  
*nsource*, 177, 178  
*nsrck*, 162, 163  
*nstart*, 80, 81  
*nstern*, 16, 18  
*nsur*, 130  
 NT, 152  
*ntfg*, 25, 26  
*nth2*, 126, 128  
 NTOTO, 12, 13, 19  
 NTOT1, 12, 13, 19  
 NTPO, 139, 140  
*nu3*, 126, 128  
*nu5*, 126, 128  
*nu8*, 128  
 NUDEL, 19  
 NUF1, 152



NuFission, 159  
*numnew*, 15  
*numold*, 15, 25, 28  
 NUSIGD, 12, 14  
 NUSIGF, 12, 13, 164  
 NVAL, 225, 226  
*nvd*, 84, 85, 87, 88  
 NWT0, 19  
 NWT1, 19  
 NxnDiffusion, 159  
 NxnScattering, 159  
 NXT, 100, 102  
 (NXT:), 72  
 NXT:, 162  
 NXT:, 1, 4, 5, 33, 44, 46, 63, 64, 69, 72, 73, 75, 77, 102, 129, 139, 185, 274, 316  
  
 OFF, 15, 93, 94, 118, 119  
 OFFCENTER, 43–45  
 OGAU, 68, 70, 72, 74, 77, 78, 210, 212  
 OLD, 214  
 OLDGEO, 31, 32, 34  
 OLDL, 15  
 OLDLIB, 9, 10, 15–17, 21, 29, 189, 192  
 OLDMIC, 111, 114  
 OLDNAME, 146, 147  
 OLDW, 16, 18  
 OMPA, 80, 81  
 OMPM, 80, 81  
 ON, 93, 100, 105  
 ONEG, 68, 69, 72, 73, 80, 210, 211  
*operand*, 232, 233  
 OPP1, 68, 70, 72, 74, 77, 78, 210, 212  
 OPTIM, 9, 117, 118  
 OPTIMIZE, 119  
 ORIG, 136, 137, 152–154  
*orig*, 136, 137, 152–154  
 OUTMC, 162  
 OVERV, 12, 14  
*overv*, 12, 14  
  
 P, 93  
 PO, 95  
 POTR, 95  
 POW, 100, 103  
 P1, 95  
 P1W\_L, 100, 103  
 P1W\_TO, 100, 103  
 Pa, 126, 127  
 PARA, 133, 134, 150, 157  
*param*, 128  
 PARKEY, 133, 134, 136, 137  
*parkey*, 122, 150, 152, 153, 157, 159, 160  
*parnam*, 122, 150  
 PARTICLE, 175–177  
 PASS, 195, 199, 200  
  
*path*, 227, 345  
*path1*, 227  
*path2*, 227  
*pcinl*, 62  
*pcorn*, 68, 71, 72, 75, 211, 213  
*pcut*, 68, 69, 72, 74, 210, 212  
 PERT, 100, 105  
 PF, 150, 151, 157, 158  
 PI, 35, 36  
 PI/2, 35, 36  
 PICK, 112, 114, 169, 170, 202  
 PICKC, 179, 180  
 PICKE, 179, 180  
 PIFI, 112, 114  
 PIJ, 89, 90, 190–193, 195, 196, 199, 200  
*pijcel*, 62  
 PIJK, 89, 90, 97  
 PIJNAM, 89, 92  
 PISO, 68, 69, 72, 73, 210, 211  
 PLAN, 139, 140  
 PLANA, 139, 140  
 PLANE, 50, 58  
 PLANP, 139, 140  
 PLUS, 144, 145  
 PN, 84, 85, 118–120, 142  
 PNL, 95, 96, 98  
 PNLR, 95, 96, 98  
 PNOR, 89, 90  
 PNTN, 72, 74, 75, 210, 212, 213  
 PNW\_SP, 100, 103  
 POINT, 229  
 POINTS, 139, 140  
*polar*, 177  
*polar/azimutal*, 178  
 POURCE, 62  
 POWER, 111, 114  
*power*, 179  
*powerdown*, 124  
*powerint*, 124  
*powerref*, 124  
*powerup*, 124  
 POWNAM, 111, 114  
 POWR, 112–115, 133, 134, 179  
 PREFIX, 146, 147  
 PRES:, 126, 127  
*pressure*, 126, 127  
 PRIM, 84, 87  
 PRIX, 68, 70  
 PRIY, 68, 70  
 PRIZ, 68, 70, 72, 76  
 PROCEL, 62  
 PROD, 100, 106, 107, 232  
 PROF, 152  
 PROM, 16, 18  
 PRTV, 87, 88

- PSFIL*, 204, 205, 207  
*PSGEO*, 185  
**(PSOUR:)**, 176  
*PSOUR:*, 176  
**(PSOUR\_data)**, 176, 177  
*PSOUR\_data*, 176  
**(PSP:)**, 185  
*PSP:*, 5, 75, 162, 185, 213  
*PSPC*, 68, 69, 72, 73, 210, 211  
*PT*, 16, 17, 19, 25–27, 194  
*PTMC*, 16, 17, 19, 25–27, 194  
*PTSL*, 16, 17, 19, 25–27, 194  
*PUIS*, 150, 151, 157, 158  
*PUR:*, 126, 127  
*purity*, 126, 127  
*puritydown*, 124, 125  
*purityref*, 124, 125  
*PUT*, 227  
*PWATER*, 126, 128  
*PWR*, 124  
*PYTHON*, 173, 174
- QRN*, 72, 75, 210, 212  
*QUA1*, 65, 66  
*QUA2*, 65, 66  
*QUAB*, 65, 67–69, 72, 73, 80, 83, 210, 211  
*QUAD*, 80, 82
- R*, 95, 97, 98  
*R+*, 35  
*R120*, 35, 36  
*R180*, 35, 37  
*RADIUS*, 43, 44  
*RADS*, 35, 37  
*rank*, 232  
*RATE*, 100, 105, 165, 166  
*REAC*, 100, 104, 150, 152, 157, 158, 169  
*reac*, 169, 170  
*reaction*, 23, 24  
*READ*, 10, 12  
*REAL*, 133, 134, 157, 158  
*real*, 223  
*REBA*, 93, 94  
*rec*, 227  
*recname*, 227  
*recname1*, 227  
*recname2*, 227  
**(RECOVER:)**, 221  
*RECOVER:*, 6, 221  
*RECT*, 65, 67, 100, 101  
*REFE*, 100, 105  
*REFGEO*, 99, 101  
*REFL*, 35, 95  
*REFPIJ*, 99  
*REGI*, 100–102, 130, 162, 163, 166, 195, 196, 199, 200
- REGION*, 185, 186  
*REL*, 187, 215, 216  
*relden*, 29  
*relvol*, 25, 27  
*REMIX*, 100, 102  
*REND*, 64, 69, 73  
*RENO*, 64, 69  
*REPEAT*, 50, 58  
*RES*, 100, 104  
*RESK*, 25, 26  
*REST*, 150, 152  
*result*, 232, 233  
*RGB*, 185, 186  
*rho*, 179, 180  
*RHOC*, 124, 125  
*RHOM*, 124, 125  
*RHS*, 95  
*RNAME*, 124  
*RNANE*, 124  
*ROOT*, 215  
*ROT+*, 65–67  
*ROTH*, 65–67  
*RPIN*, 43, 45  
*rpin*, 63  
*rpins*, 43, 45  
*rrad*, 35, 37  
*rRoot*, 229  
*rrr*, 43, 44  
*rs*, 61  
*RSE*, 16, 17, 19, 194  
*RTHETA*, 31, 33  
*RUNG*, 112, 113
- S*, 93, 112, 113, 136, 152, 153, 159, 160  
**(S2M:)**, 172  
*S2M:*, 172  
**(S2M\_data)**, 172  
*S2M\_data*, 172  
*S30*, 35, 36  
*S90*, 35, 36  
*SA180*, 35, 37  
*SA60*, 35, 36  
*SADD*, 215, 216  
**(SALT:)**, 209  
*SALT:*, 64, 139, 209, 210, 213  
*SAME*, 50, 58  
*SANC*, 65, 67  
*SAP*, 214  
**(SAP:)**, 149  
*SAP:*, 5, 7, 115, 148–150  
*SAPHYB*, 5, 7, 117, 118, 122  
**(saphyb\_data1)**, 149, 150  
*saphyb\_data1*, 149  
**(saphyb\_data2)**, 149, 152  
*saphyb\_data2*, 149  
**(saphyb\_data3)**, 149, 153

*saphyb\_data3*, 149  
 SAPNAM, 117–119, 122, 149, 153, 154  
 SAPNEW, 117, 122  
 SAPO, 65, 67, 68, 70, 72, 73, 80, 83, 210, 211  
 SAPRHS, 149, 153, 154  
 SAT, 25, 27, 109, 112–114  
 SATOFF, 112, 113  
 SAVE, 100, 104, 105, 112, 115, 147  
 SB180, 35, 37  
 SB60, 35, 36  
 SC, 77, 79  
 SCAT, 13, 14, 80, 81, 84, 85, 87, 88, 164  
 Scattering, 159  
 SCHM, 80, 81  
 SCR, 77, 79  
*sdsa*, 80, 82  
 SECT, 43, 44  
 SEED, 162, 163, 199, 200  
 SELE, 119, 121  
 SELE\_ALB, 118, 120  
 SELE\_EDF, 118, 121  
 SELE\_FD, 118, 120  
 SELE\_MWG, 118, 121  
 SELF, 152  
*sens.save*, 167  
*SENS.sdf*, 167  
*sens.x2m*, 167  
 (SENS:), 167  
 SENS:, 5, 167  
 (SENS\_data), 167  
*SENS\_data*, 167  
 SEQ\_ASCII, 3, 345  
 SEQ\_BINARY, 3, 345  
 SET, 112, 115, 136, 152, 153, 159, 160  
 SETI, 187  
 SETLOOP, 232  
 (SHI:), 189  
 SHI:, 5, 6, 25, 28, 189  
 SHIB, 25, 26  
 SIDE, 43, 44  
*sideh*, 43, 44  
 SIGS, 95, 96, 98  
 SKIP, 16, 19, 89, 90  
 SLSI, 65, 67, 68, 70, 72, 73, 80, 83, 210, 211  
 SMS, 72, 75, 210, 212, 213  
 SN, 80, 81, 118–120, 173, 174  
 (SNDMPI:), 233  
 SNDMPI:, 233  
 SNNN, 152  
 (SNT:), 80  
 SNT:, 4, 8, 63, 80, 90, 92, 93  
*snumb*, 179  
 SOUNAM, 92  
 SOUR, 179  
 SOURCE, 165, 176  
 SOURCE, 92  
 SOURCE2, 176  
 SPH, 106, 183, 184, 192, 193, 199, 200, 314  
*sph*, 118, 119  
 (SPH:), 117  
 SPH:, 5, 117  
 SPHE, 61  
 SPHERE, 31, 32, 44–46, 50, 65, 80  
 SPLITH, 43, 44  
 SPLITL, 43, 45  
 SPLITR, 43, 44, 236  
 SPLITX, 43  
 SPLITY, 43  
 SPLITZ, 43, 44  
 SPN, 84, 85, 87, 88  
 SPOP, 118, 119  
 SPRD, 118, 119  
 SSYM, 35, 69, 73, 95  
 STABLE, 23, 24  
 STAT, 100, 105, 215, 216  
 (STAT:), 224  
 STAT:, 6, 224  
 STD, 118, 120  
 STD\_FISS, 118, 121  
 STEP, 10, 12, 118, 119, 133, 136–138, 146, 147, 159, 160, 214, 215, 220, 221, 225  
 STERN, 16, 18  
 STIS, 77, 79  
 STRD, 152  
 STRNAME, 3  
 STRUCT, 227  
 SUBG, 16, 17, 19, 194, 198  
 SUBGEO, 32, 34  
*suffix*, 195, 196, 199, 200  
 SUM, 232  
 SURF, 130  
 SURFIL, 99, 101, 204, 207, 209, 210  
 SURFIL\_IN, 204  
 SUS3D, 173, 174  
*svdeps*, 16, 17, 19  
 SYBIL, 100, 102  
 (SYBILT:), 65  
 SYBILT:, 1, 4, 6, 7, 46, 63, 65, 66, 90, 106, 120, 121, 191, 193, 196, 200, 234, 235, 237, 239, 242, 244, 277  
 SYME, 35, 36, 50, 69, 73, 95  
 SYMM, 68, 71, 72, 74  
 (T:), 164  
 T:, 5, 164  
 TAKE, 100, 102, 105  
 TALLY, 162, 163  
 TALLY ENDT, 163  
*tburn*, 17, 21  
 TCOH, 25, 26  
 TCOOL, 124

- tcooldown*, 124  
*tcoolref*, 124  
*tcoolup*, 124  
**TCWU05**, 316  
**TDXS**, 112, 114  
**TEMP**, 133, 134, 142, 143, 150, 151, 157  
*temp*, 25, 26, 126, 127  
*tempd*, 25, 26  
**TEST**, 217  
**TEXT4**, 118, 122  
**TEXT80**, 118, 122  
**TFILEEXT**, 129  
**TFILEMOD**, 129  
**TFILENEW**, 129  
**TFILEOLD**, 129  
**TFUEL**, 124, 125  
*tfueldown*, 124, 125  
*tfuelref*, 124, 125  
*tfuelup*, 124, 125  
**THER**, 25, 26, 93, 94  
**THO2**, 126, 128  
**TIME**, 133, 134, 149–151, 156–158, 232, 233  
**TISO**, 68–70, 72–74, 210–212, 277  
**TITL**, 64  
**TITLE**, 64, 124  
**TIXS**, 112, 114  
**(TLM:)**, 139  
**TLM:**, 5, 76, 139, 213  
**TMER**, 68, 69  
**TMODE**, 124  
*tmodedown*, 124, 125  
*tmoderef*, 124, 125  
*tmodeup*, 124, 125  
**TMP:**, 126, 127  
**TMT**, 77, 79  
**TO**, 144, 233  
*to*, 233  
**TOL**, 229  
*tol*, 229  
**(TONE:)**, 192  
**TONE:**, 5, 6, 25, 28, 192, 193  
**TOP1**, 152  
**TOTA**, 152  
**TOTAL**, 12, 13  
**Total**, 159  
**TotalP1**, 159  
**TOUT**, 150–152, 157, 158  
**TRACK**, 162, 165, 176  
**TRACKING**, 7, 63, 65, 68, 72, 77, 80, 84, 87, 89, 92, 99, 102, 111, 118, 129, 139, 174, 189, 192, 195, 199, 209, 242, 243  
**TRACKN**, 115  
**TRAK**, 68, 70  
**TRAN**, 35, 36, 142, 152, 190, 192, 193, 195, 196, 199, 200  
**TRANC**, 11–13  
**TREG**, 68, 69  
**TRIA**, 100–102  
**(TRIVAT:)**, 87  
**TRIVAT:**, 4, 63, 87  
**TRKENEW**, 129  
**TRKEOLD**, 129  
**TRKFIL**, 68, 69, 72, 73, 77, 89, 92, 117, 118, 139, 189, 192, 194, 195, 198, 199, 209, 211  
**TRKFLP**, 92  
**TRKGPT**, 92  
**TRKNAM**, 102  
**TRKNAM**, 65, 68, 72, 75, 77, 80, 84, 87, 89, 92, 99, 111, 117, 118, 139, 167, 185, 189, 192, 194, 195, 198, 199, 209  
**TRKNNEW**, 129  
**TRKNOLD**, 129  
*true*, 229  
**TSPC**, 68, 69, 71–75, 210–213, 277  
**TUBE**, 31, 32, 44–46, 50, 59, 61, 65, 80  
**TUBEX**, 31, 32, 44–46, 50, 58, 59  
**TUBEY**, 31, 32, 44–46, 51, 58, 59  
**TUBEZ**, 31, 33, 44–46, 51, 59, 80  
**TURN**, 50, 59, 279  
*tval*, 142, 143  
**TYPE**, 100, 106  
**TYPE**, 93, 185, 186, 225, 227  
*type*, 227  
**TYPE B**, 96  
**TYPE K**, 96  
**TYPE L**, 96  
*typgeo*, 205  
**TYPSEC**, 144  
**U**, 139, 140  
**UNFOLD**, 100, 102  
**UNKT**, 93, 94  
**UO2**, 126, 128  
**UP**, 118, 119, 133, 134, 136–138, 214, 215, 220, 221, 225  
**UPDL**, 15  
**UPS**, 100, 118, 122  
**UPTO**, 50, 59  
**(USS:)**, 194  
**USS:**, 5–7, 194, 195  
**(UTL:)**, 215  
**UTL:**, 6, 215  
**V**, 139, 140  
**VAL**, 215  
*val*, 144, 145  
*valb2*, 95, 97, 98  
*valbr2*, 95, 98  
*valbx2*, 95, 98  
*valby2*, 95, 98

- valbz2*, 95, 98
- valc*, 215–217
- VALE, 144, 145, 150, 151
- valeps*, 190, 192, 193
- valeps1*, 112, 113
- valeps2*, 112, 113
- valexp*, 109, 112, 113
- valh1*, 112, 113
- valk*, 95, 98
- VALU, 133, 134, 157, 158
- value*, 136, 137, 144, 145, 152–154, 159, 160, 217, 218, 225–228, 233, 336
- values*, 336
- (VDG:), 202
- VDG:, 189, 202
- VECT, 87, 88
- VIRTUAL, 31, 32, 65
- VOID, 35, 84, 85, 87, 88, 90, 94, 95, 97, 106, 120
- VOLTRK, 173, 174
- VOLUME, 10, 11
- volume*, 10, 11
  
- W/CC, 112, 113, 115
- WARNING-ONLY, 137, 153, 154, 160
- WATER, 126–128
- WGT%, 126–128
- WGTANGL, 173
- WIGN, 65, 66
- WIMS, 10, 11, 16, 18
- WIMSAECL, 16, 20, 126, 127
- WIMSD4, 16, 20, 126, 127
- WIMSE, 16, 20
- WORLD-SIZE, 232
- WRIT, 10, 11
  
- X, 95, 97, 98, 229
- X+, 35, 43, 50–53, 58, 59, 177
- X-, 35, 43, 50–53, 58, 59, 177
- X-/X+, 178
- x1*, 100, 102, 229
- x2*, 100, 102, 229
- x3*, 100, 102
- XABORT(), 230
- xadf*, 13, 15
- XCLL, 8, 68, 69, 72, 73
- xdiffx*, 12, 13
- xdiffy*, 12, 14
- xdiffz*, 12, 14
- xepsi*, 77, 78
- xhdd*, 77, 79
- xi*, 177
- XIR, 124, 125
- XLIM, 177
- xm*, 100, 101
- xmax*, 177
- xmin*, 177
- xmin/xmax*, 177
- xp*, 100, 101
- xpins*, 43, 45
- xrad*, 35, 37
- xschi*, 12, 13
- xschid*, 12, 14
- xsfixe*, 12, 13
- xsint0*, 12, 14
- xsint1*, 12, 14
- XSM\_FILE, 3, 345
- xsscatt*, 13, 14
- xssigl*, 12, 13
- xssigd*, 12, 14
- xssigf*, 12, 13
- xssigt*, 12, 13
- xsstra*, 12, 13
- xtf*, 112, 113
- xti*, 112–114
- xtr*, 112, 136, 152, 153, 159, 160
- xts*, 112
- xxx*, 43
  
- Y, 95, 97, 98, 229
- Y+, 35, 43, 50–53, 58, 59, 177
- Y-, 35, 43, 50–53, 58, 59, 177
- Y-/Y+, 178
- y1*, 100, 102, 229
- y2*, 100, 102, 229
- y3*, 100, 102, 229
- YEAR, 112, 113, 136, 137, 152, 153, 159, 160
- yield*, 23, 24
- YLIM, 177
- ym*, 100, 101
- ymax*, 177
- ymin*, 177
- ymin/ymax*, 178
- yp*, 100, 101
- ypins*, 43, 45
- yyy*, 43
  
- Z, 95, 97, 98
- Z+, 35, 43, 51–56, 58, 59, 177
- Z-, 35, 43, 51–56, 58, 59, 177
- Z-/Z+, 178
- ZAFIL\_IN, 204
- ZERO, 35, 36
- ZLIM, 177
- zmax*, 177
- zmin*, 177
- zmin/zmax*, 178
- ZOOMX, 205, 207
- ZOOMY, 205, 207, 208
- zpins*, 43, 45
- zzz*, 43